

ICES WGNPBW REPORT 2006

**ICES ADVISORY COMMITTEE ON FISHERY MANAGEMENT
ICES CM 2006/ACFM:34**

REPORT OF THE NORTHERN PELAGIC AND BLUE WHITING FISHERIES WORKING GROUP (WGNPBW)

24-30 AUGUST 2006

ICES HEADQUARTERS

DRAFT



**International Council for the Exploration of the Sea
Conseil International pour l'Exploration de la Mer**

International Council for the Exploration of the Sea Conseil International pour l'Exploration de la Mer

H.C. Andersens Boulevard 44-46
DK-1553 Copenhagen V
Denmark
Telephone (+45) 33 38 67 00
Telefax (+45) 33 93 42 15
www.ices.dk
info@ices.dk

Recommended format for purposes of citation:

ICES. 2006. Report of the Northern Pelagic and Blue Whiting Fisheries Working Group (WGNPBW), 24-30 August 2006, ICES Headquarters. ICES CM 2006/ACFM:34. 289 pp.
For permission to reproduce material from this publication, please apply to the General Secretary.

The document is a report of an Expert Group under the auspices of the International Council for the Exploration of the Sea and does not necessarily represent the views of the Council.

© 2006 International Council for the Exploration of the Sea.

Contents

0	Executive Summary	1
1	Introduction.....	2
1.1	Participants.....	2
1.2	Terms of Reference.....	2
2	Ecological considerations	4
2.1	Ecosystem overview	4
2.1.1	Barents Sea.....	4
2.1.2	Norwegian Sea	4
2.1.3	Icelandic waters.....	7
2.1.4	Hydrography of the waters west of the British Isles	8
2.2	Ecosystem impact on the fish stocks.....	8
2.2.1	Norwegian spring spawning herring	8
3	Norwegian Spring Spawning Herring	24
3.1	Stock description.....	24
3.1.1	General	24
3.1.2	Changes in migration	24
3.2	ICES advice and management applicable to 2005 and 2006	25
3.3	Description and development of the fisheries in 2005	26
3.3.1	Denmark.....	26
3.3.2	Germany.....	26
3.3.3	Faroe Islands	27
3.3.4	Iceland.....	27
3.3.5	Ireland	27
3.3.6	Netherlands	28
3.3.7	Norway.....	28
3.3.8	Russia.....	28
3.3.9	Sweden.....	29
3.3.10	UK (Scotland)	29
3.3.11	Poland	29
3.3.12	France.....	29
3.4	Bycatches in the fishery	29
3.5	Fishery dependent data.....	29
3.5.1	Sampling intensity.....	29
3.5.2	Landings.....	29
3.5.3	Discards.....	30
3.5.4	Age and length composition of catches.....	30
3.5.5	Weight at age	31
3.5.6	Length at age.....	31
3.5.7	Maturity at age	31
3.5.8	Natural Mortality.....	32
3.6	Fisheries independent data	32
3.6.1	Survey abundance indices	32
3.6.2	Tagging data.....	35
3.7	Stock Assessment.....	36
3.7.1	Catch curve analyses	36
3.7.2	Data Exploration with assessment models	36
3.7.3	Comparison of results of different assessments	43

3.7.4	Final Assessment.....	44
3.8	Recruitment estimates	44
3.9	Forecast.....	45
3.9.1	Short term forecast	45
3.10	Biological reference points	45
3.11	Management considerations.....	45
3.12	Quality of the data and the assessment	45
3.13	Recommendations.....	47
4	Blue whiting.....	126
4.1	Stock description.....	126
4.2	ICES advice and management applicable to 2005 and 2006	126
4.2.1	Management plan for the blue whiting fishery.....	127
4.2.2	NEAFC regulatory measurements	128
4.3	Description and development of the fisheries in 2005	129
4.3.1	Denmark.....	129
4.3.2	Germany.....	129
4.3.3	Faroe Islands	130
4.3.4	France.....	130
4.3.5	Iceland.....	130
4.3.6	Ireland	131
4.3.7	Netherlands	131
4.3.8	Norway.....	131
4.3.9	Portugal	132
4.3.10	Russia.....	132
4.3.11	Spain	132
4.3.12	Sweden.....	133
4.3.13	UK (Scotland)	133
4.4	Bycatches in the fishery	133
4.4.1	Icelandic investigations (land based sampling).....	133
4.4.2	Faroese investigations at sea	134
4.5	Fishery dependent data.....	134
4.5.1	Sampling intensity.....	134
4.5.2	Landings.....	134
4.5.3	Discards.....	135
4.5.4	Age and length composition of catches.....	135
4.5.5	Weight at age	136
4.5.6	Length at age.....	136
4.5.7	Maturity at age	136
4.5.8	Natural mortality	136
4.5.9	CPUE data.....	136
4.5.10	Effort data	137
4.6	Fishery independent data	137
4.6.1	International Blue Whiting survey on the spawning grounds	137
4.6.2	International ecosystem survey in the Norwegian Sea.....	139
4.6.3	Iceland acoustic summer survey	140
4.6.4	Norwegian Sea summer survey.....	140
4.6.5	Russian survey in the Barents Sea.....	140
4.6.6	Spanish bottom trawl survey	141
4.6.7	Portuguese bottom trawl survey	141
4.6.8	Faroese plateau spring bottom trawl survey.....	141
4.6.9	Icelandic bottom trawl survey - spring.....	142

4.6.10	Icelandic deep water shrimp survey	142
4.6.11	Icelandic bottom trawl survey - autumn.....	143
4.6.12	Faroes plateau autumn bottom trawl survey.....	143
4.6.13	Norwegian shrimp survey in the North Sea	144
4.6.14	Norwegian bottom trawl survey in the Barents Sea	144
4.6.15	Russian egg survey.....	144
4.7	Stock assessment.....	145
4.7.1	Evaluation of data underlying the assessment.....	145
4.7.2	Data exploration with AMCI.....	146
4.7.3	Data exploration with ISVPA	147
4.7.4	Data exploration with ICA	148
4.7.5	Data exploration with SMS.....	150
4.7.6	Data exploration with XSA.....	152
4.7.7	Comparison of results of different assessments	153
4.7.8	Final assessment.....	154
4.8	Recruitment estimates	155
4.9	Forecast.....	156
4.9.1	Short term forecast	156
4.9.2	Medium term forecast	157
4.10	Biological reference points	157
4.11	Management considerations.....	158
4.12	Quality of the data and the assessment	158
4.13	Evaluation of the “Arrangement for the Multi-Annual management of the Blue whiting Stock”	159
4.13.1	Methodology	160
4.13.2	Simulations.....	162
4.13.3	Evaluation of the initial conditions	164
4.13.4	Conclusion	165
4.14	Recommendations.....	165
5	Capelin in the Iceland-East Greenland-Jan Mayen area	271
5.1	The Fishery	271
5.1.1	Regulation of the fishery	271
5.1.2	The fishery in the 2005/2006 season.....	271
5.2	Catch Statistics.....	272
5.3	Surveys.....	272
5.3.1	0-group and 1-group surveys in August.....	272
5.3.2	Abundance of immature age 1 and 2 capelin in autumn 2005 and 2006.....	272
5.3.3	The adult fishable stock	273
5.4	Historical Stock Abundance.....	274
5.5	Stock Prognoses	274
5.5.1	Stock prognosis and TAC in the 2006/2007 season.....	274
5.5.2	Stock prognosis and assessment for the 2007/2008 season.....	274
5.5.3	Management of capelin in the Iceland-East Greenland-Jan Mayen area	274
5.6	Precautionary Approach to Fisheries Management.....	275
5.7	Special Comments	275
5.8	Sampling	276
6	Working documents.....	287

Annex 1: List of Participants288

0 Executive Summary

The ICES northern pelagic and blue whiting fisheries working group (WGNPBW) met for 7 days in August 2006 to assess the state of two stocks, blue whiting and Norwegian spring spawning herring. Age-based assessments were carried out for both stocks. This year an update of the Icelandic capelin was also made, but last year it was assessed in NWWG.

For blue whiting 5 assessment models were used to explore the data. All models show the same trend in spawning stock biomass and fishing mortality. Historically they are at similar levels, but depart from each other in recent years. Final assessment was made with SMS. The spawning stock biomass in 2006 is estimated at 5 million tons. The assessments indicate a decline in spawning stock biomass from 2005 to 2006, which is not seen in the spawning stock surveys. Recruitment has been exceptionally good since 1996, but indices from surveys suggest that year class 2005 is a poor one.

During the working group meeting an evaluation of the "Arrangement for the Multi-Annual management of the Blue whiting Stock" was made. Simulations done by the working group indicated that limiting interannual changes to 100 thous. tons as in the agreement would lead to increased fishing mortality in coming years when the goal was to reduce the fishing mortality gradually from current level to 0.32. See conclusions in 4.13.4.

Three models were used to explore the data of Norwegian spring spawning herring. Contradictory to earlier years they all gave the same perception of the current stock size. Final assessment was done by the same model as last year. This year's assessment is an upward revision of last year's assessment. There are many reasoning for this. This year tagging data could not be used as the tagging effort is not enough and magnets to detect tags are only located in Norway. The last 4 years in the winter survey are excluded, as it is believed that they have not covered the whole stock. The 2002 year class is estimated strong and is considered now almost fully matured, which is exceptional at age 4. The spawning stock biomass is estimated at almost 11 million tons and has not been larger since 1957, but it is dominated by 4 years old herring, that is the 2002 year class.

Regarding the development of a new joint Russian-Norwegian assessment model for Norwegian spring spawning herring then it has changed to be a joint model framework. It is aimed to have a working prototype at WGNPBW in 2007.

Since 2001 the Icelandic capelin have changed their migrations and distribution so radically that with the present state of knowledge it has proven impossible to predict the abundance of the adult stock in the manner used successfully for numerous years previously.

The working group nominates Frans van Beek and Morten Vinther as the next co-chairs for the group.

1 Introduction

1.1 Participants

NAME	E-MAIL
Frans A. van Beek	fransa.vanbeek@wur.nl
Sergei Belikov	belikov@pinro.ru
Hoskuldur Bjornsson	hoski@hafro.is
Afra Egan	afra.egan@marine.ie
Asta Gudmundsdóttir (Chair)	asta@hafro.is
Mikko Heino	mikko@imr.no
Jens Chr. Holst	jens.christian.holst@imr.no
Ane Iriondo	airiondo@suk.azti.es
Jan Arge Jacobsen	janarge@frs.fo
Alexander Krysov	a_krysov@pinro.ru
Manolo Meixide	manolo.meixide@vi.ieo.es
Webjörn Melle	webjoern@imr.no
Nikolay M. Timoshenko	timoshenko@atlant.baltnet.ru
Sigurd Tjelmeland	sigurd.tjelmeland@imr.no
Dimitri A. Vasilyev	dvasilyev@vniro.ru
Morten Vinther	mv@dfu.min.dk
Sytse Ybema	Sytse.Ybema@wur.nl

1.2 Terms of Reference

2005/2/ACFM15 The Northern Pelagic and Blue Whiting Fisheries Working Group [WGNPBW]:

- a) assess the status of and provide management options for 2007 for the Norwegian spring-spawning herring stock and the blue whiting stock;
- b) provide as detailed information as possible on the age/size composition in different segments of the blue whiting fishery;
- c) compile existing information on discards and by-catch in the fisheries;
- d) enumerate the number, capacity and effort of vessels prosecuting the fishery by country;
- e) Reconsider the biological reference points in particular for Norwegian spring spawning herring;
- f) for the stocks mentioned in a) perform the tasks described in C.Res. 2005/2/ACFM01.

In ToR f) referring to C.Res. 2005/2/ACFM01 is given below:

WGSSK, WGSSDS, WGHMM, WGMHSA, WGBFAS, WGNSDS, AFWG, HAWG, NWWG, WGNPBW and WGPAND will, in addition to the tasks listed by individual group in 2006:

- (1) based on input from e.g. WGRED and for the North Sea NORSEPP, consider existing knowledge on important environmental drivers for stock productivity and management and if such drivers are considered important for management advice incorporate such knowledge into assessment and prediction, and important impacts of fisheries on the ecosystem;

- (2) Evaluate existing management plans to the extent that they have not yet been evaluated. Develop options for management strategies including target reference points if management has not already agreed strategies or target reference points (or HCRs) and where it is considered relevant review limit reference points (and come forward with new ones where none exist) following the guidelines from SGMAS (2005, 2006), AGLTA (2005) and AMAWGC (2004, 2005, and 2006); If mixed fisheries are considered important consider the consistence of options for target reference points and management strategies. If the WG is not in a position to perform this evaluation then identify the problems involved and suggest and initiate a process to perform the management evaluation;
- (3) where mixed catches are an important feature of the fisheries assess the influence of individual fleet activities on the stocks and the technical interactions;
- (4) update the description of fisheries exploiting the stocks, including major regulatory changes and their potential effects. Comment on the outcome of existing management measures including technical measures, TACs, effort control and management plans. The description of the fisheries should include an enumeration of the number, capacity and effort of vessels prosecuting the fishery by country;
- (5) where misreporting is considered significant provide qualitative and where possible quantitative information, for example from inspection schemes, on its distribution on fisheries and the methods used to obtain the information; document the nature of the information and its influence on the assessment and predictions.
- (6) provide for each stock and fishery information on discards (its composition and distribution in time and space) and the method used to obtain it. Describe how it has been considered in the assessments;
- (7) report as prescribed by the Secretariat on a national basis an overview of the sampling of the basic assessment data for the stocks considered;
- (8) provide specific information on possible deficiencies in the 2006 assessment including, at least, any major inadequacies in the data on landings, effort or discards; any major inadequacies in research vessel surveys data, and any major difficulties in model formulation; including inadequacies in available software. The consequences of these deficiencies for both the assessment of the status of the stocks and the projection should be clarified.
- (9) Further develop and implement the roadmap for medium and long term strategy of the group as developed by AMAWGC.
- (10) Working Group Chairs will set appropriate deadlines for submission of the basic assessment data. Data submitted after the deadline will be considered at a later meeting at the discretion of the WG Chair.

2 Ecological considerations

2.1 Ecosystem overview

2.1.1 Barents Sea

An overview of the ecological status of the Barents Sea in 2006 is given by the AFWG (ICES 2006).

2.1.2 Norwegian Sea

2.1.2.1 Hydrography and climate

The Nordic Seas (Fig. 2.1.2.1.1) during the last decades have been characterized by increased input of Arctic waters. The Arctic waters to the Norwegian Sea are mainly carried by the East Icelandic Current (EIC) and also to some extent by the Jan Mayen Current. During periods of increased Arctic water input, the western extension of Atlantic water is moved eastward. As a result, over the last 25 years the southern and western Norwegian Sea has become colder and fresher while the eastern Norwegian Sea is warmed. Atmospheric forcing drives this trend. From mid 1960's the winter North Atlantic Oscillation index (NAO) has increased to beginning of the 1990s followed by a reduction to the long-term-mean (Fig. 2.1.2.1.2). NAO is an indicator of the strength of the westerly winds into the Norwegian Sea. A high NAO index (i.e. stronger westerly winds) will force Atlantic and Arctic waters more eastward. In winter 2006 the index was lower than normal.

The Institute of Marine Research, Norway, has measured temperature and salinity in three standard sections in the Norwegian Sea almost regularly since 1978. The sections are 1) the Svinøy section which runs NW from 62.37° N at the Norwegian coast, 2) the Gimsøy section which also runs NW from the Lofoten Islands and 3) the Sørkapp section which is a zonal section at 76.33° N just south of Svalbard.

Figure 2.1.2.1.2 shows the development in temperature and salinity in three different sections from south to north in the Norwegian Sea. During the last 10-12 years the temperature and salinity in the Svinøy section have increased linearly. The temperatures have the last five years been extraordinary high. In 2006 the temperature had the second highest value in the times series and was 0.8 °C above normal. Only in 2003 was the temperature higher. The salinity has also been very high the last five years and in 2006 the salinity in the Svinøy section was about 0.07 above normal. Unfortunately some data are missing in the Gimsøy and Sørkapp sections during the last years. For both sections the temperature and salinity have increased the last years. In 2006, the temperature and salinity in the Gimsøy section were the highest ever in the time series, 1.0 °C and 0.08 above the long-term-means. The warm and saline water observed the last years are due to warmer and more saline Atlantic water entering through the Faroe-Shetland Channel.

The area of Atlantic water (defined as water with $S > 35.0$) in the Svinøy-section has been calculated. The mean temperature within the limited area has also been calculated, and the results for both spring and summer are shown in Fig. 2.1.2.1.3. There are considerable variations both in the area of Atlantic water distribution and its temperature. Temperature has increased linearly by 0.8 °C since 1978. During the years 1992-1995 the area was much smaller than average for both seasons, probably due to strong westerly winds. The summer temperature had the three largest values in the time series during 2002-2004 but in 2005 it dropped, close to the long-term-mean. However, in summer 2006 the temperature increased again to the same record-high value as in 2003. The area of Atlantic water was in summer 2006 above the long-term-mean.

During research cruises in May with the main aim of measuring the stock size of pelagic fishes, hydrographic observations are also taken, covering most of the Norwegian Sea (figures are not shown). In May 2006 there was a larger influence of Arctic water in the southern Norwegian Sea compared to 2005. In the western part of the Norwegian Sea it was reported that the Atlantic Water was about 0.25-0.75°C colder in 2006 than in 2005.

Conclusions:

- The winter NAO index in 2006 was lower than normal.
- In May 2006, there was an increased influence of Arctic water, from the EIC, and the western Norwegian Sea was then about 0.25-0.75°C colder in May 2006 compared to May 2005.
- The averaged summer temperature of the Atlantic Water in the Svinøy section has increased linearly with approximately 0.8°C since 1978, and was in 2006 the highest ever in the time series.
- Along the slope (near the shelf), the summer temperatures in the core of the Atlantic Water in the Svinøy section have been very high the last five years. In 2006 it was the second highest in the time series, about 0.8 °C above the long-term-mean.
- The summer temperature in the core of Atlantic water along the slope was the highest ever in the Gimsøy section, about 1.0 °C above normal.
- The salinity in the core of Atlantic Water at the slope (near the shelf) has the last years been very high, and in 2006 it was record-high in the Gimsøy section.

2.1.2.2 Phytoplankton

The development of phytoplankton in the Atlantic water is closely related to the increase of incoming solar irradiance during March and to the development of stratification in the upper mixed layer due to warming. The Institute of Marine Research, Norway, started in 1990 a long-term study of the mechanisms controlling the development of phytoplankton at Ocean Weather Station Mike situated at 66°N, 2°E.

Figure 2.1.2.2.1 shows the development of the phytoplankton bloom for 2003 expressed as chlorophyll *a* concentration at the surface. In previous years there has been a marked difference in the time when the spring bloom reached its maximum. In 1997 the spring bloom reached its maximum 20 May (day of the year 140), in 1998 about one month earlier 18 April (day of the year 108). The timing of the bloom in 1999 was similar to that in 1998, but did not show the same high maximum in chlorophyll. This may be related to the weekly measurements in 1999, as opposed to daily measurements in 1997 and 1998. On the other hand, weekly measurements prior to 1997 have revealed pronounced maxima in chlorophyll. The reason for the low algal biomass in 1999 may have been early and strong grazing from a large over-wintered zooplankton stock. In all these years a strong peak has characterized the bloom. The situation in 2001 was different to previous years. First, the spring bloom started somewhat later (first week of May) compared to 1998 and 1999 and was followed by relatively moderate chlorophyll concentrations culminating with a major peak in the first week of June. Also a distinct early autumn bloom was observed in the middle of August. In 2002 the springbloom started to develop in the middle of April reaching its maximum at the end of April, resulting in one of the earliest bloom second only to the bloom in 1998. The 2003 bloom also maintained relatively high chlorophyll concentrations for about a month after the first peak on May 8 to decrease rapidly afterwards. After the main spring bloom four other smaller blooms were observed throughout the summer and early autumn.

The development of the phytoplankton prior to the spring bloom may be separated into two phases. The first phase, from day 1 to about day 50, is characterised by extremely low phytoplankton biomass expressed as chlorophyll *a*. This is the winter season during which phytoplankton growth is mainly limited by the low incoming irradiance typical of this period.

The second phase, from about day 50 to day 100, is characterised by a gradual increase of phytoplankton biomass but without reaching bloom conditions. This is the pre-bloom phase during which the increase in biomass is related to the increase in incoming irradiance and the lack of a bloom is due to the deep upper mixed layer still present at this time.

Figure 2.1.2.2.2 shows the extension in time for these two phases and the timing of the spring bloom for the period 1991-2003. In a "normal" year the winter season extends to about 2 March. The pre-bloom phase extends on average from the 2 March to 16 April. The spring bloom starts normally on 16 April and reaches its maximum on 21 May, but the year-to-year variations are much larger than those of the previous phases. From 1991 to 1995 the trend was towards earlier spring blooms. This trend was broken in 1996, and thereafter year-to-year variability in the timing of the bloom has been greater but with a trend towards earlier blooms again after 2001. This analysis has not been updated after 2003.

Conclusions:

- The phytoplankton bloom in 2003 developed earlier than the average since 1991, third only to the 1998 and 2002 blooms.
- Chlorophyll *a* concentrations first peaked in the first week of May 2003 and were maintained at relatively high levels until the first week of June resulting in the longest bloom in the time series. This could, as in 2002, have been the result of a relaxation in the grazing pressure.
- During summer and early autumn of 2003 several peaks of relatively high chlorophyll *a* concentration were observed indicating a strong variability in minor blooms.

2.1.2.3 Zooplankton

Zooplankton biomass distribution in the Norwegian Sea has been mapped annually in May (since 1995) and in July (1994-2002). The summer sampling was resumed in 2005, but data are not available yet. Zooplankton samples for biomass estimation were collected by vertical net hauls (WP2) or oblique net hauls (MOCNESS). The May cruise is the ICES coordinated international survey of the Norwegian Sea ecosystem. Figure 2.1.2.3.1 shows distribution of zooplankton biomass during the ICES coordinated surveys of the Norwegian Sea ecosystem in May 2006. As usual, biomass of zooplankton was highest in the Arctic waters of the western Norwegian Sea and the Icelandic Sea.

In the present report Norwegian zooplankton samples from the upper 200 m are analysed. Total zooplankton biomass (g dry weight m⁻²) in May was averaged over sampling stations within three water masses, Atlantic water (defined by salinity >35 at 20 m depths), Arctic water (salinity <35, west of 1.4°E) and Coastal water (salinity <35, east of 1.4°E) (Fig. 2.1.2.3.2). In Atlantic and Arctic water masses zooplankton biomass decreased to a minimum in 1997. Thereafter zooplankton biomass increased again and remained relatively high except for a temporary reduction in 2001. After 2002 there has been a continuous reduction and in 2006 the second lowest biomass during the time series was measured. Reduction in biomass has been most notably in Arctic water, and in 2006 the lowest biomass during the time series was observed. Due to reduced cruise time the Arctic water mass was not sampled in 2001 and 2004. Zooplankton biomass in Arctic water is generally higher than in Atlantic and coastal water, but in 2002, 2005 and 2006 the biomass in Arctic and Atlantic water equalled. In 2005 the highest biomass of the Norwegian Sea was found in coastal water. In the coastal water mass, which includes the Norwegian continental shelf and slope waters influenced by Norwegian coastal water, the temporal pattern of variation in biomass is different from the other two water masses.

In July the total zooplankton biomass (g dry weight m⁻²) in the upper 200 m was calculated by integrating biomass at sampling stations within a selected area in the central and eastern

Norwegian Sea. There is no obvious trend in the zooplankton biomass in July since 1994 (Figure 2.1.2.3.3).

Conclusions:

- Average zooplankton biomass in Atlantic water masses of the Norwegian Sea in May 2006 was much lower than average and the second lowest for the time series.
- Biomass in coastal water in 2005 was for the first time higher than in Arctic and Atlantic water. Also in 2006 biomass in coastal water was high relative to the other water masses.

2.1.2.4 Predictions for zooplankton biomass

The North Atlantic Oscillation index (NAO), is a proxy for the strength and duration of southwesterly winds, and is correlated with the inflow of Atlantic water to the Norwegian Sea. In the Norwegian Sea the average biomass of zooplankton in Atlantic water in May is significantly correlated with the average NAO for the March-April period the previous year (Fig. 2.1.2.4.1). However, the model has consistently overestimated the biomass since 2003. This may be related to changes in the processes underlying the relationship. March-April is the period when the primary production in the Norwegian Sea is initiated and the major reproductive period for many important zooplankton species such as *Calanus finmarchicus* and krill. The one-year lag in the relationship may be because we in May mainly measure the size of the overwintering stock, i.e. the previous years production and the present years spawning stock. Based on this relationship the biomass for May 2007 is estimated at 9.5 g dry weight m⁻². Due to the tendency towards overestimation by the model during the most recent years, we perceive this an overestimate as well.

$$Biomass (yr2) = 2.3 * NAO yr1 + 10.1 \quad (1)$$

$$R^2 = 0.44, P = 0.02$$

Conclusions:

- The average NAO for March-April the previous year is directly related to zooplankton biomass in May and herring condition in the autumn.
- The biomass of zooplankton in 2007 is predicted at 9.5 g dry weight m⁻² by the model, but is expected to be lower.

2.1.3 Icelandic waters

2.1.3.1 Hydrography and climate

As Iceland is situated at a meeting place of warm and cold currents its waters are characterised by highly variable conditions especially in the area north and northeast of the country. Heat and salt content in those waters depend on the strength of Atlantic inflow through the Denmark Strait and the variable flow of polar water from the north with the East Icelandic Current. South and west of Iceland fluctuations are smaller.

Climatic conditions in the North Atlantic improved around 1920 and remained rather warm until the mid-1960s, when they deteriorated. In the area north and east of Iceland temperature and salinity declined sharply in 1965 and these severely cold conditions lasted until 1971. After that, climatic conditions off north and east of Iceland improved, but were variable and years have alternated with cold years (Fig. 2.1.3.1.1).

Salinity and temperature increased in 1997 west of Iceland and have remained high. This increase in the Atlantic character of the Irminger Current reached into the northern area and peaked in 1999 and prevailed until winter and spring 2002 when a rather short period of polar

influence was observed. In summer 2002 a persistent inflow of Atlantic water started and kept on throughout the year 2003 with little winter cooling which resulted in a record year in temperature and salinity north and east of Iceland. Observations in February 2004 showed continued influence of Atlantic water in the northern and eastern area with stronger winter cooling and high salinities.

Temperature in the warm Atlantic waters south and west of Iceland in 2005 was 5-7°C and salinity 35.10-35.27, i.e. high values like during the last years. There was a considerable Atlantic inflow eastwards onto the N-Icelandic shelf, reaching to the east of Melrakkasletta. However, there was a fresh and moderately warm surface layer over most of the Atlantic water, north, northeast and east of Iceland – remains of the ice which drifted east off the north coast earlier this spring. Nevertheless, both temperature and salinity in the upper layers were around or higher than the long term average north of Iceland, but somewhat lower than during most recent years.

In the East Icelandic Current outside the shelf edge northeast of Iceland, temperature and salinity were near the long-time average, while the southern limit of the ‘cold tongue’ reached further south than during the last years. East of Iceland, temperature and salinity in the upper layers were 2-3°C and 34.5-34.9 respectively, which is somewhat colder than in the last years. This data series is not updated for 2006.

2.1.3.2 Zooplankton

In the area north of Iceland, zooplankton biomass tends to be higher in years with strong inflow of Atlantic Water than in years when Atlantic inflow is weak, and lower salinity in the surface layers slows or prevents vertical mixing. A strong inflow of Atlantic water to the north Icelandic area was observed both during November 2002 and February/March 2003. The relatively high zooplankton biomass off the central north coast in spring 2003 is in line with this (Fig. 2.1.3.2.1). A continued strong inflow of Atlantic water to the north Icelandic area was observed during recent years surveys. On the whole, the zooplankton biomass in Icelandic waters in 2005 and 2006 was above average.

2.1.4 Hydrography of the waters west of the British Isles

Hydrographic data have been collected during surveys in the spawning season of blue whiting in spring. The mean temperature and salinity from 50 to 600m of all the stations in deep water (bottom depth > 600m) in 2° latitude times 2° longitude boxes have been calculated for each survey. The box with limits 52° to 54°N and 16° to 14°W had few gaps, and the time series of mean temperature and salinity for this box is shown in Figure 2.1.4.1. The pattern seen is that after some years with temperatures around 10.1°C in the 1980s, it dropped to a minimum in 1994 (~9.8°C). After 1994 an increase in temperature is seen, and in 1998 temperature reached a local maximum (~10.5°C) with the three following years a few tenths of a degree colder. 2002 was a warm year with ~10.7°C, and in 2003 the temperature dropped to (~10.5°C). A warming occurred in 2004 (~10.8°C), but 2005 (~10.4°C), was colder than the three preceding years. 2006 was the warmest on record (above 11°C). The increase in temperature coincides with the increase in recruitment of blue whiting. However, it is not known whether there is a causal relationship between hydrographic conditions and recruitment of blue whiting.

2.2 Ecosystem impact on the fish stocks

2.2.1 Norwegian spring spawning herring

Feeding and growth

Individual growth of the Norwegian spring spawning herring, as measured by condition or length specific weight after the summer feeding period in the Norwegian Sea, has been characterised by large fluctuations during the 1990's (Fig 2.2.1.1). During 1991 and 1993

individual condition was good, but from 1994 on the condition of the herring started to decline and by 1997 it reached the lowest level during the 1990's. The level observed in 1997 corresponds with the absolute long-term low level observed during the period 1935 – 1994 (Dr. scient. thesis J.C. Holst 1996, University of Bergen). Following a recovery during 1998 and 1999, the condition of the herring decreased again. From 2001 to 2005 the condition remained at a low level, showing very little variation.

Since 1995 the large-scale migration pattern of the herring has been mapped during two annual cruises, May and July-August (terminated in 2002). During this period the herring have been feeding most heavily in Atlantic water, and the herring condition index obtained after the feeding period in the Norwegian Sea is related to average zooplankton biomass of Atlantic water (Fig. 2.2.1.2). This relationship could be improved by defining herring feeding areas more precisely, because large variations in herring migration routes and in zooplankton distribution have been observed over the years. Extreme changes in herring migration occurred during the summers 2004 and 2005 when increasing amounts of herring started to feed in the southwestern Norwegian Sea, north of the Faeroes and east of Iceland. At the same time we observed that increasing numbers of herring were not overwintering in the fjords of northern Norway, but in the deep waters off the shelf. The herring which are still overwintering inside the fjords had much higher condition than the herring outside, probably due to differences in migration route and feeding conditions between the two groups of overwintering herring. Since 2004 we have used the condition factor of the herring outside the fjord in Fig. 2.2.1.2 (see also 3.9).

A regression of herring condition on two-months averages of the NAO indices showed that the relationship was strongest between herring condition and the NAO during the March-April period (Fig. 2.2.1.3). The prediction for 2006 and 2007 based on equation (2) is 0.812, somewhat below average. The condition factor for 2004 and 2005 was calculated for the fraction of the stock overwintering outside the fjords, and the predictions for 2006 and 2007 are probably valid only for the same part of the stock (see 3.9).

$$\text{Condition (yr2)} = 0.021 * \text{NAO yr1} + 0.82 \quad (2)$$

$$R^2 = 0.44, P = 0.007$$

Recruitment

Predictions of the recruitment in fish stocks are essential for future harvesting of fish stocks. Traditionally, prediction methods have not included effects of climate variability. Multiple linear regression models can be used to incorporate both climate and fish parameters. Especially interesting are the cases where there exists a time lag between the predictor and response variables as this gives the opportunity to make a prediction. A model for the number of three year old recruits of Norwegian spring spawning herring using the herring 0-group log index and the NCEP skin temperature describes ~80 % of the variation in the recruitment (Figure 2.2.1.4).

The model is:

$$Rec_t = 8.3 \times skin_{t-3} + 16 \times 0group_{t-3} - 44$$

where Rec is the number (in 10^9) of 3 year old recruits of Norwegian spring spawning herring from the WGNPBW 2003 SEASTAR assessment (ICES 2004), $skin$ the NCEP skin (sea surface) temperature in °C in the Norwegian Sea (64 -70°N, 6°W – 8°E) averaged from January to March 3 years earlier and the 0-group log index of herring larvae from the survey in the autumn 3 years earlier. The subscripts denote the time lag in years. Further details can be found in Stiansen *et al.* (2002).

The dominant variable in the model is the 0-group index, which has a correlation coefficient of 0.84 with the Recruitment (3 years later). When the model was tested on the 0-group index alone it gave an R^2 of 0.71. Still the model explained 9 % more of the variability when adding the skin temperature.

The prognosis shows a steady increase in recruitment for the period 2005-2007, ending at a historic high level in 2007 (Recruits 3 years old: 2005 – 9.9×10^9 , 2006 – 15.8×10^9 , 2007 – 26.8×10^9).

Conclusions:

- Herring condition was lower than average for the time series in 2005.
- There is a weak positive relationship between zooplankton biomass in May and herring condition in the autumn during the years 1995-2005. The March-April NAO index for 2004 and 2005 predicts the herring condition index at 0.812 after the feeding seasons of 2006 and 2007.
- Recruitment is predicted to increase during the period from 2005 to 2007.

References

- ICES 2004. Report of the Northern Pelagic and Blue Whiting Fisheries Working Group. ICES CM 2004/ACFM: 24.
- ICES. 2006. Report of the Arctic Fisheries Working Group (AFWG), 19-28 April 2006, ICES Headquarters, Copenhagen, Denmark. ACFM: 20.
- Stiansen, J.E., Loeng, H., Svendsen, E., Petterson, L., Johannessen, J., Furevik, T., Handegaard, N.O. and Frennd, O. 2002. Climate-fish interactions in Norwegian waters. Fisk. Hav., 12.

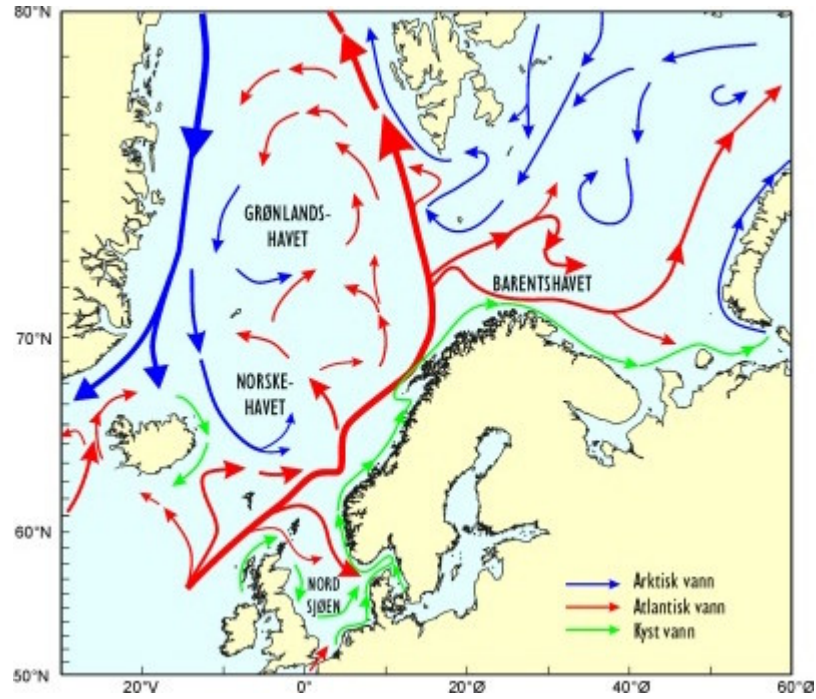

Figure 2.1.2.1.1. Main surface currents of the Nordic Seas.

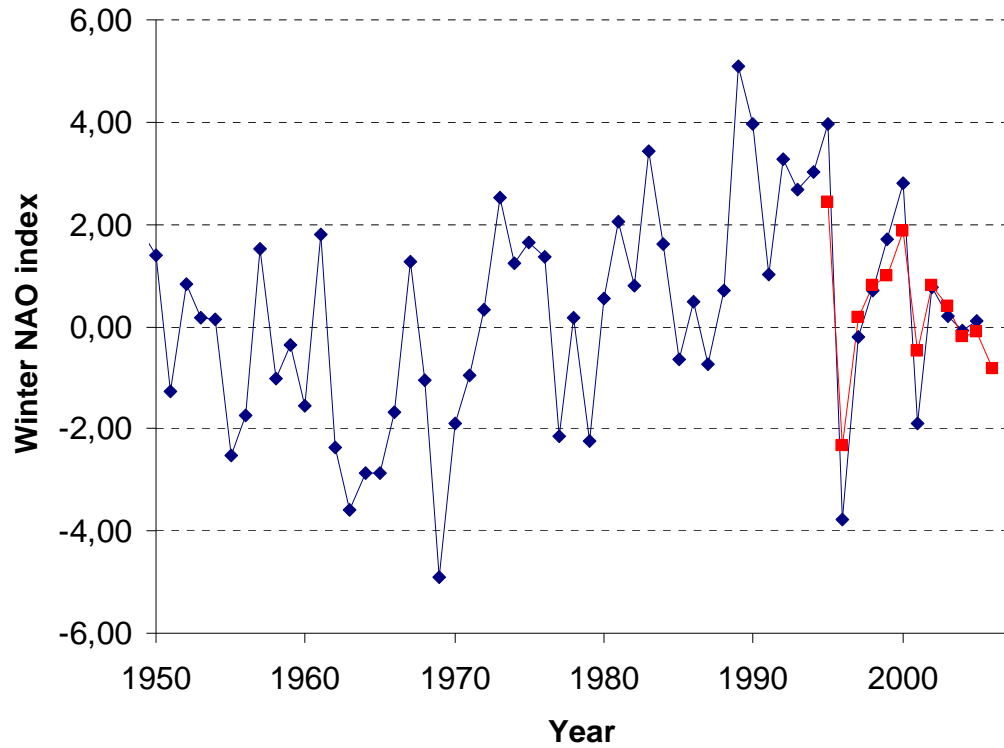

Figure 2.1.2.1.2. Hurrell's winter NAO index (Lisbon-Stykkisholmur/Reykjavik), from 1950 to 2005 (blue line), and Osborn's winter NAO index (Gibraltar-Southwest Iceland) from 1995 to 2006 (red line).

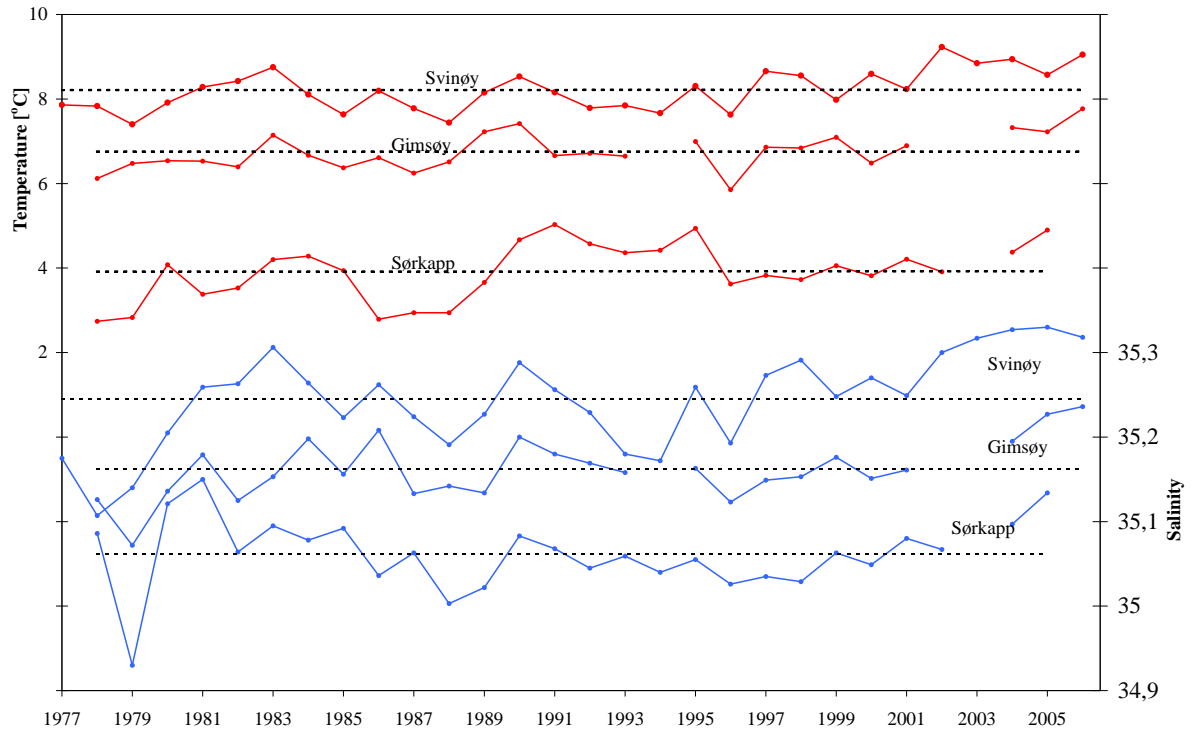

Figure 2.1.2.1.2. Temperature (°C) and salinity observed during July/August, in the core of Atlantic Water beyond the shelf edge in the sections Svinøy - NW, Gimsøy - NW and Sørkapp - W, averaged between 50 and 200 m depth and horizontally over three stations across the core.

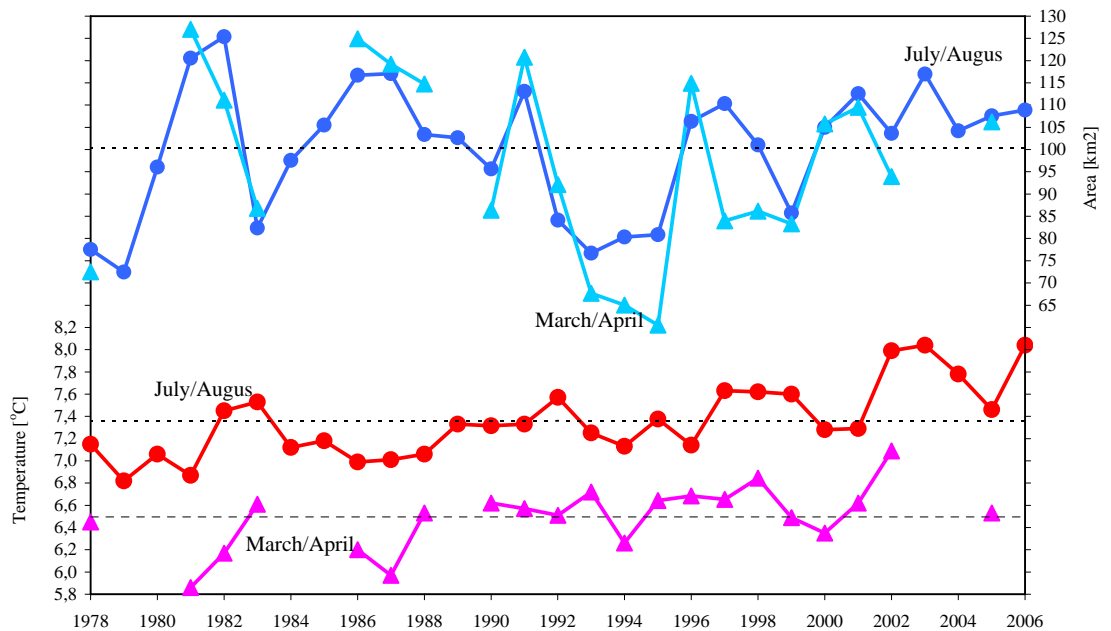

Figure 2.1.2.1.3. Time series of area (blue, in km²) and averaged temperature (red/pink) of Atlantic water in the Svinøy section, observed in March/April (triangles) and July/August (dots) 1978-2006.

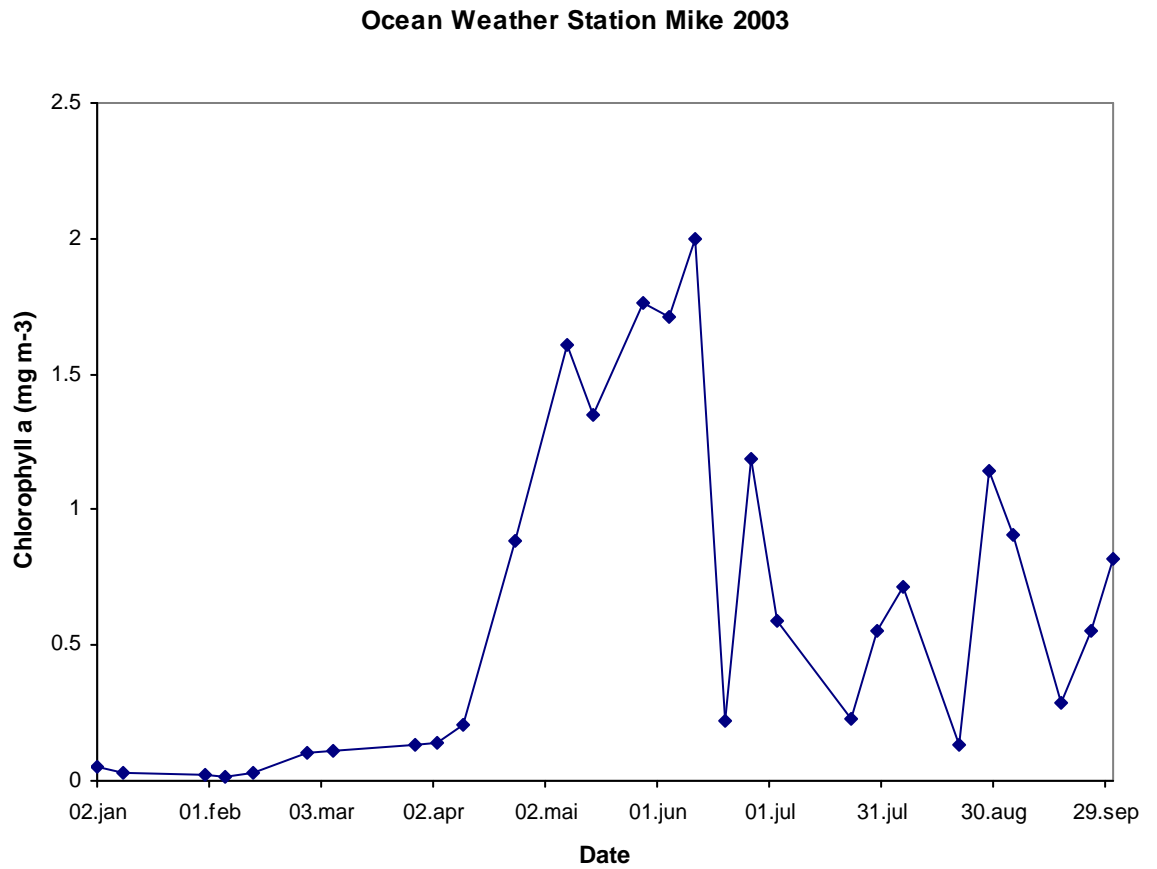

Figure 2.1.2.2.1 Distribution of chlorophyll a at 10 m depth during the year at Weather Station Mike in 2003.

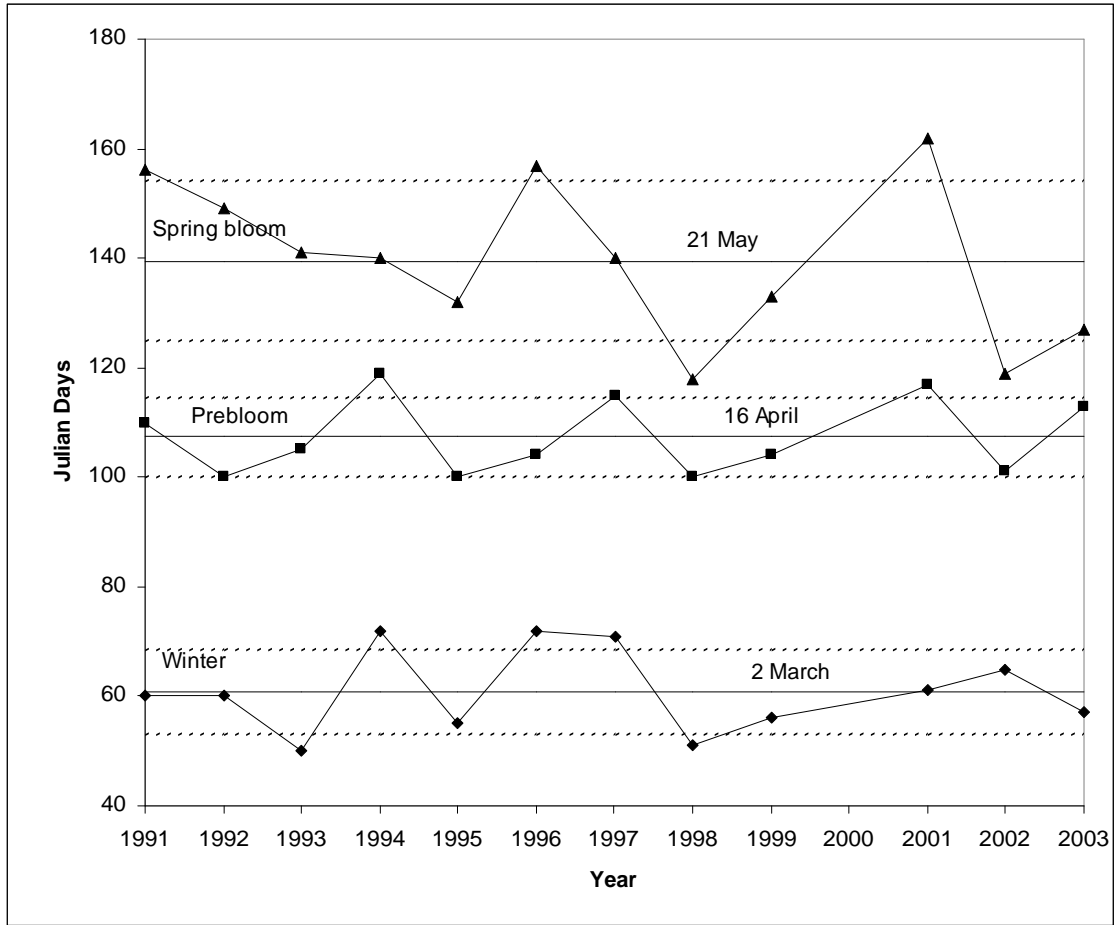

Figure 2.1.2.2.2 Year to year variations in the different phases of the development of phytoplankton at Weather Station Mike in the period 1991 to 2003. Diamonds: winter phase; squares: pre-bloom phase; triangles: spring bloom. Continuous lines represent the average for each phase. Broken lines represent one standard deviation for each phase.

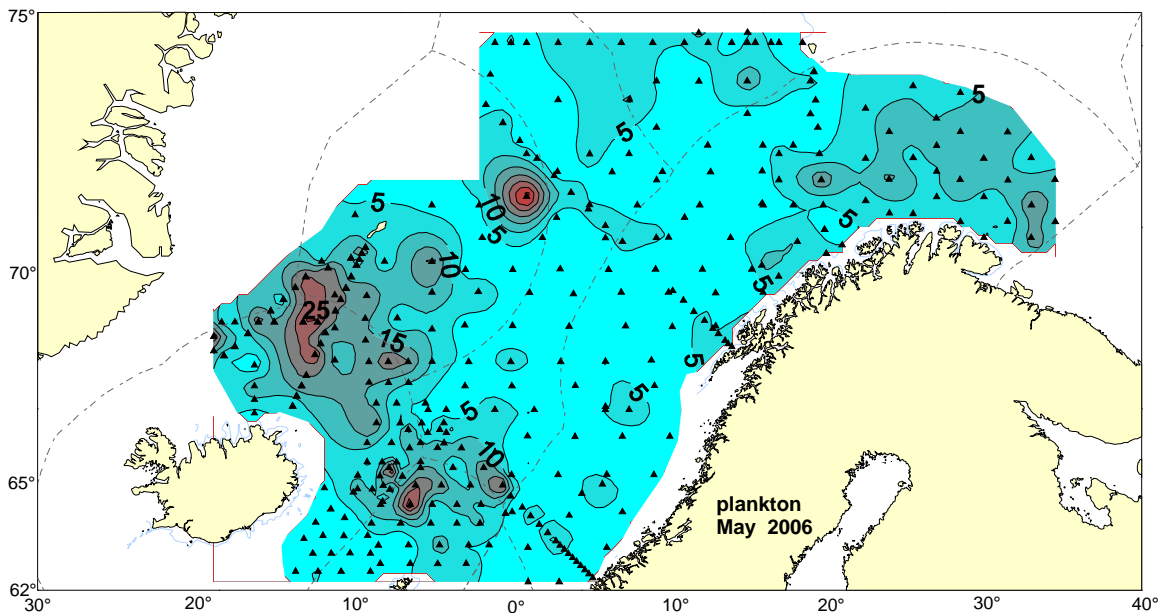

Figure 2.1.2.3.1 Distribution of zooplankton biomass (g dry weight m⁻²) in the upper 200 m. Sampled by WP2 net hauls during the ICES coordinated surveys of the Nordic and Barents Seas ecosystem in May 2006.

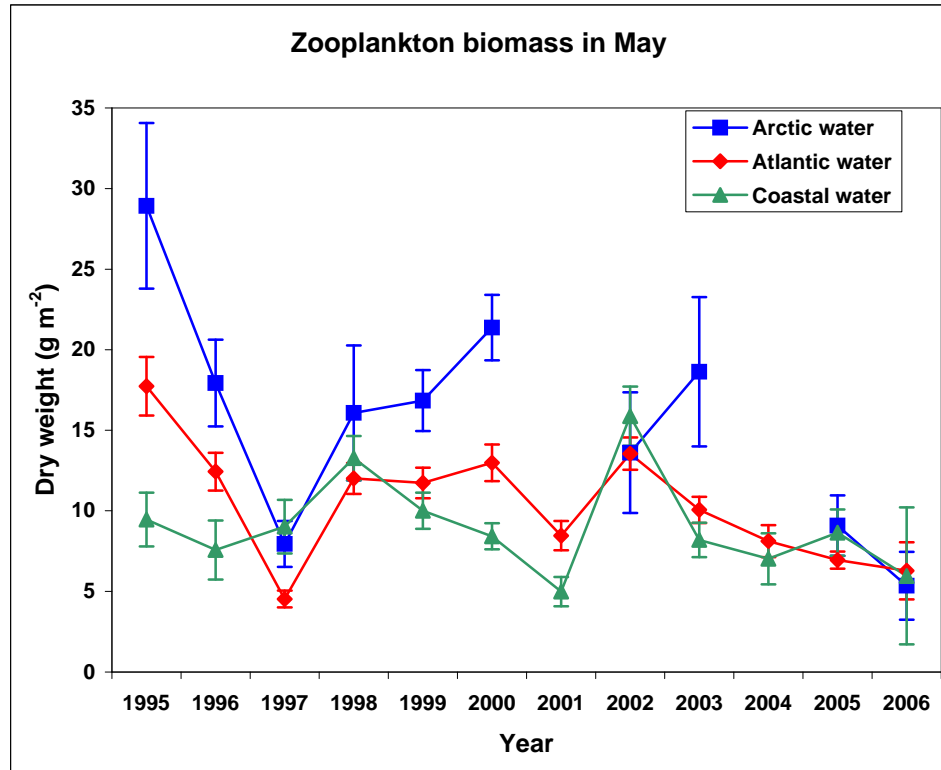

Figure 2.1.2.3.2 Zooplankton biomass (dry weight) in the upper 200 m in May. A: Arctic influenced water (salinity <35, west of 1.4°E). B: Atlantic water (salinity >35). B: Norwegian Coastal water (salinity <35, west of 1.4°E). Error bars: 95% confidence limits.

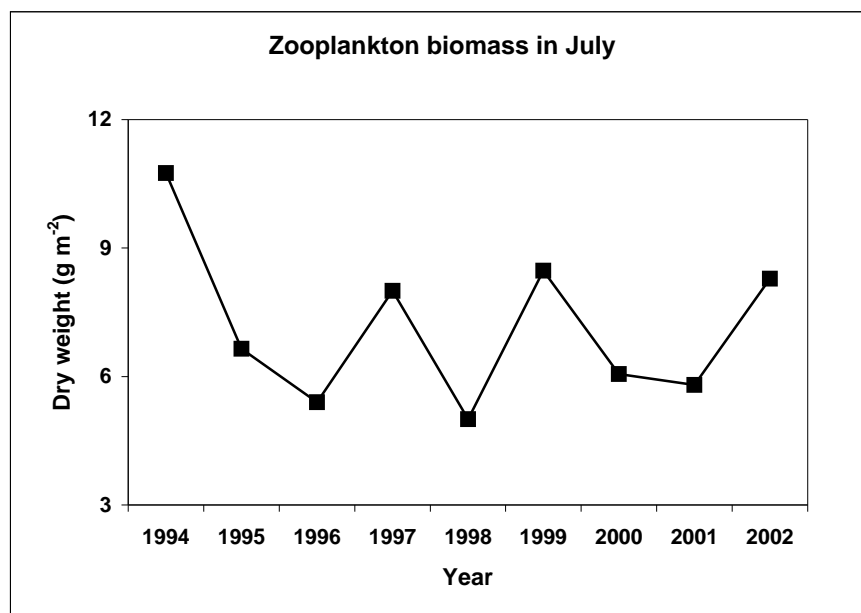

Figure 2.1.2.3.3 Zooplankton biomass in July-August in the eastern Norwegian Sea (0-200 m). Integrated biomass within a fixed geographical region divided by its area.

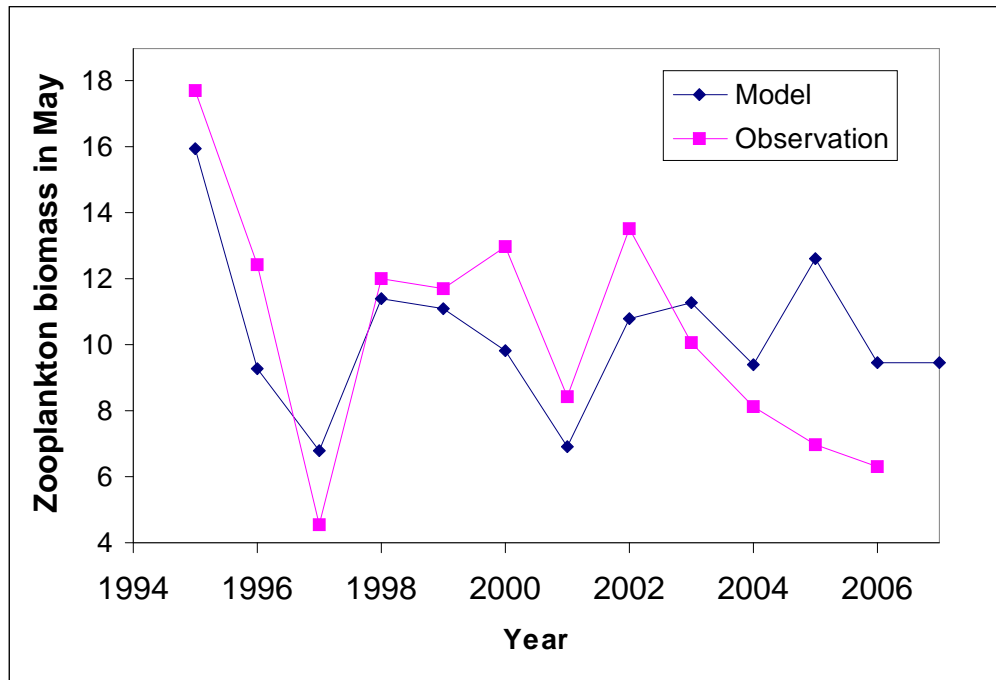

Figure 2.1.2.4.1. Zooplankton biomass in May, observed and modelled. Model: $Biomass (yr_{n+1}) = 2.3 * NAO yr_n + 10.1$. $R^2 = 0.44$, $P = 0.02$. The model predicts a biomass of 9.51 g dry weight m⁻² for May 2007.

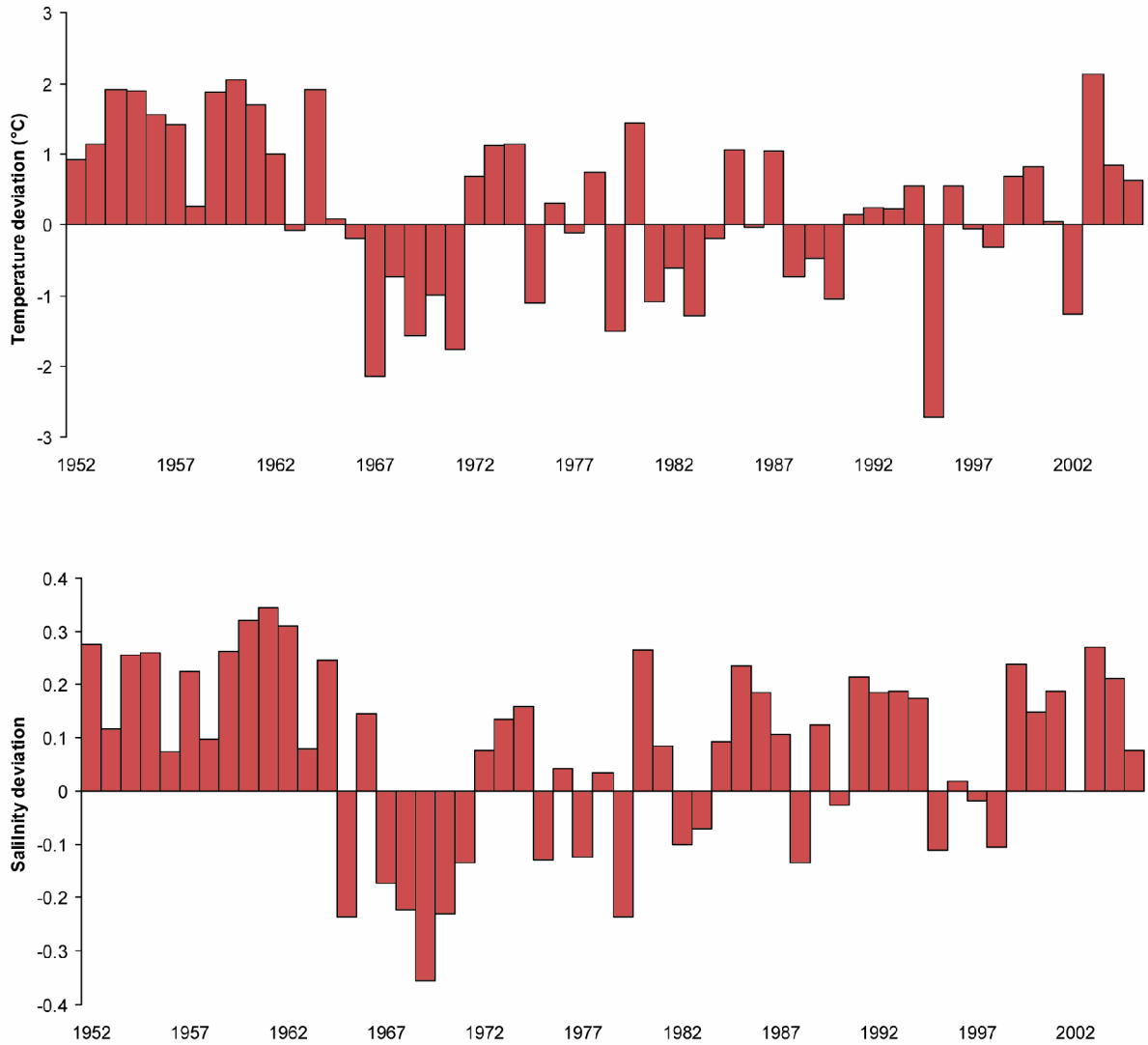

Figure 2.1.3.1.1. Temperature and Salinity deviations on the Siglunes section north of Iceland, mean for stations 1-5 and 0 – 200m, 1952 – 2005.

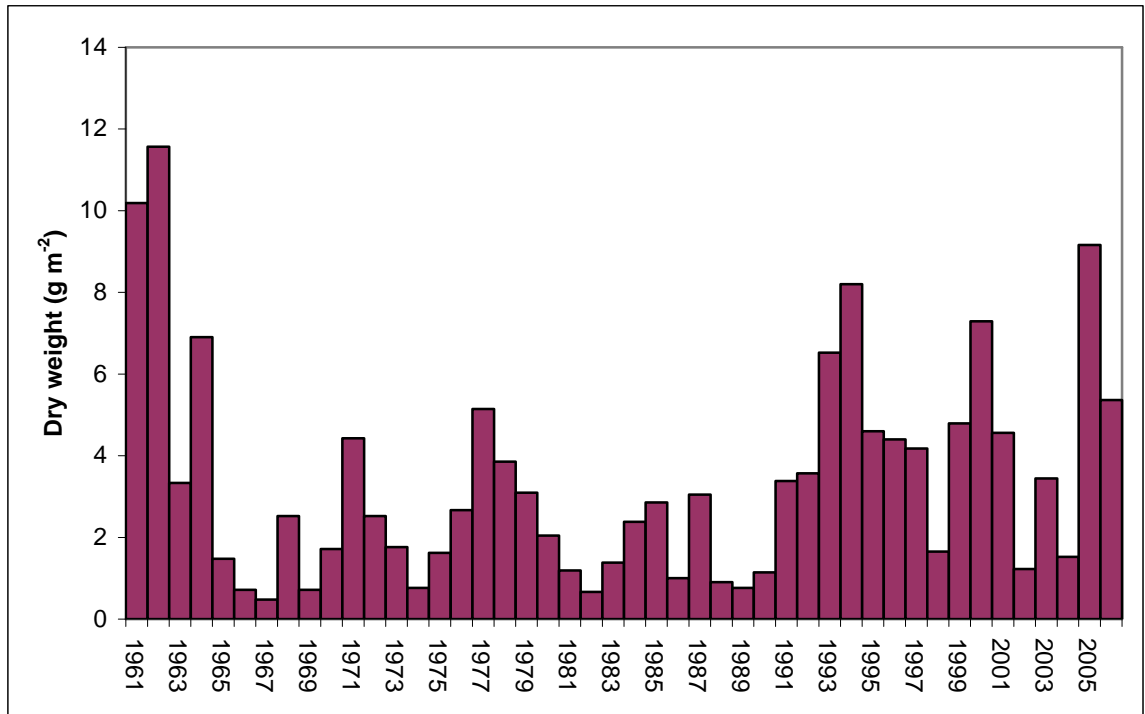

Figure 2.1.3.2.1. Variations in zooplankton biomass (g dry weight m⁻², 0-50 m) in spring at Siglunes section. The columns show means for 8 stations.

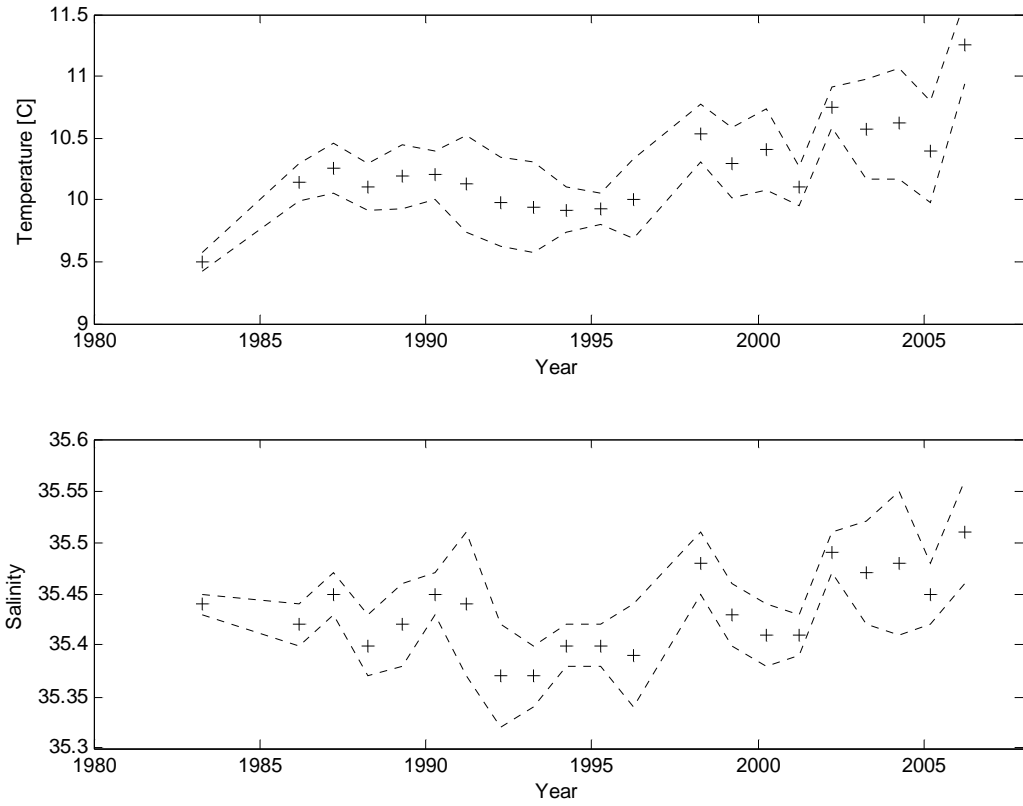

Figure 2.1.4.1. Yearly mean temperature and salinity from 50-600m (crosses) of all stations in a box with bottom depth >600m, west of the Porcupine bank bounded by 52° to 54°N and 16° to 14°W. Dotted lines are drawn at plus-minus one standard deviation of all observations in each box, each year.

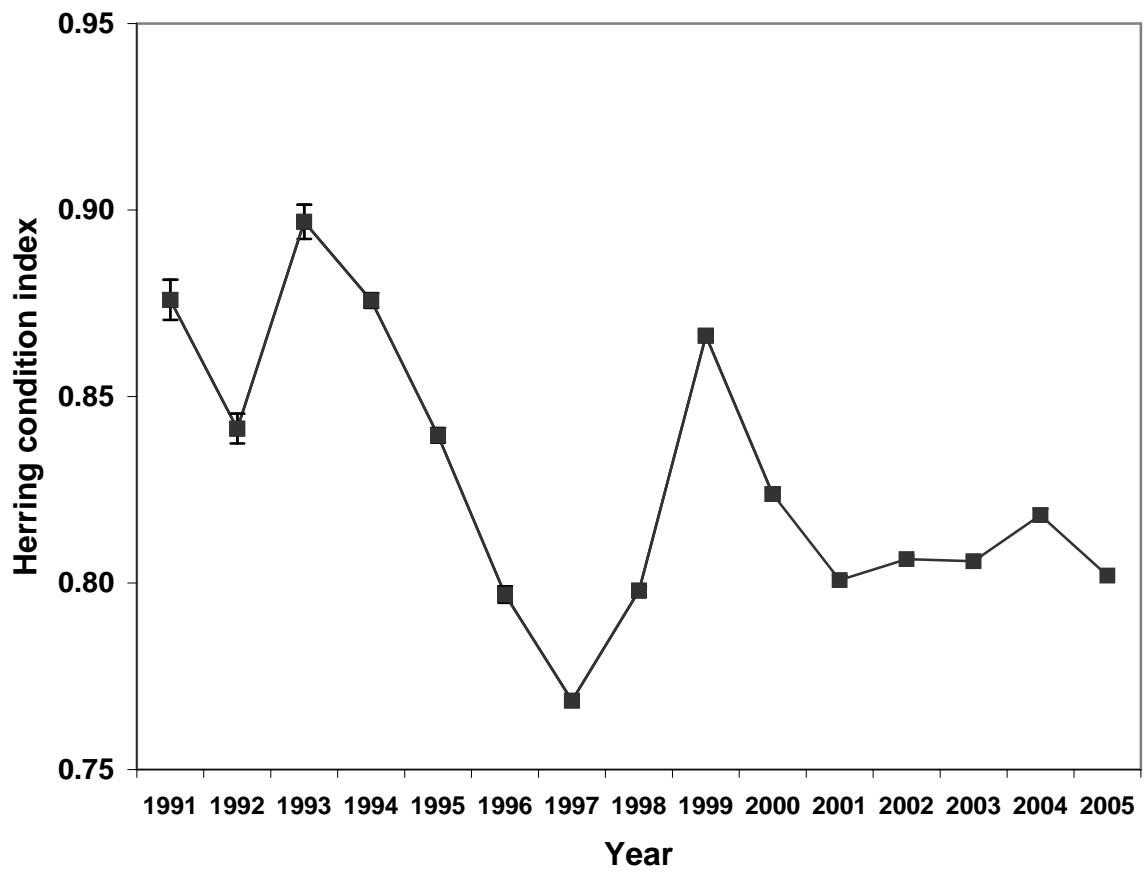

Figure 2.2.1.1 Individual weight to length ratio (herring condition index) for Norwegian spring spawning herring. Data from November and December for herring 30-35 cm body length. Error bars: 95% confidence limits. In 2004 only herring wintering outside the Ofoten-fjord were used.

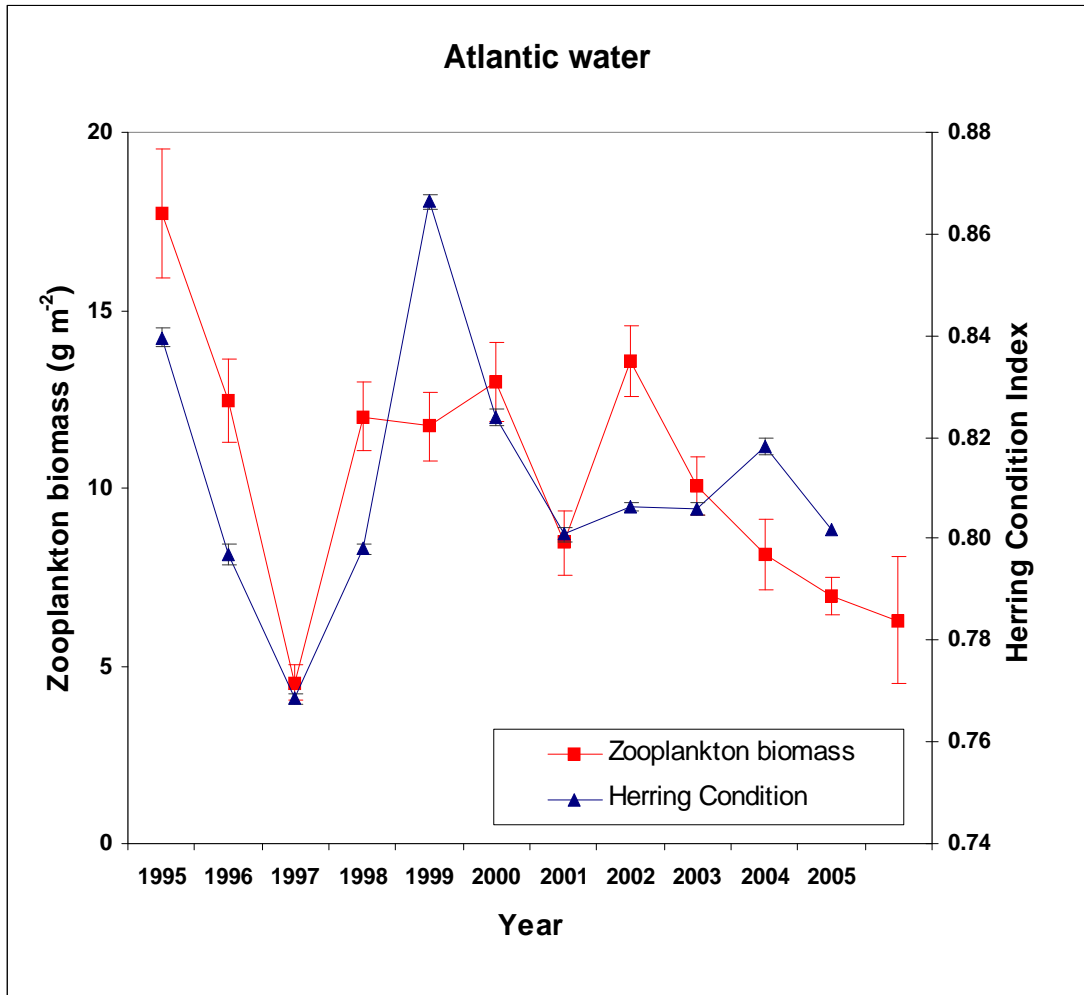

Figure 2.2.1.2 Zooplankton biomass (dry weight) in Atlantic water in the Norwegian Sea in May (0-200 m) and herring condition index (individual weight to length ratio, November and December, 30-35 cm). Error bars: 95% confidence limits. Linear regression: $\text{Condition} = 0.004 * \text{biomass} + 0.768$, $R^2 = 0.33$, $P = 0.06$.

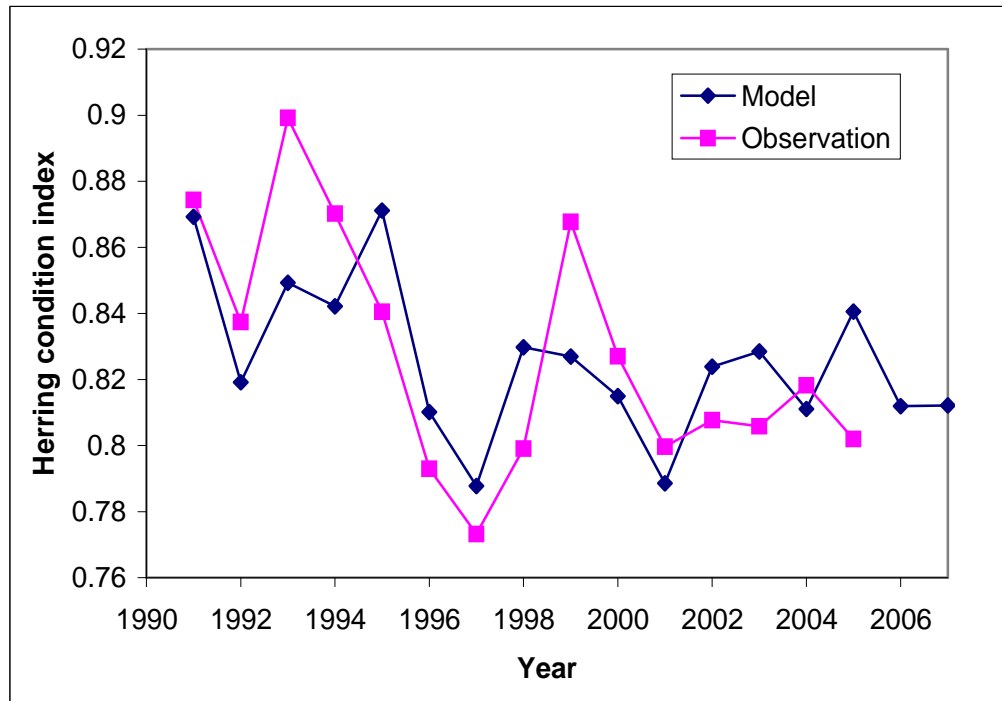

Figure 2.2.1.3 Herring condition index in December, observed and modelled. Model: Condition (yr2) = 0.021*NAO yr1 + 0.82, R² = 0.44, P = 0.007. The model predicts herring condition index in December, both in 2006 and 2007, at 0.812.

NSS herring

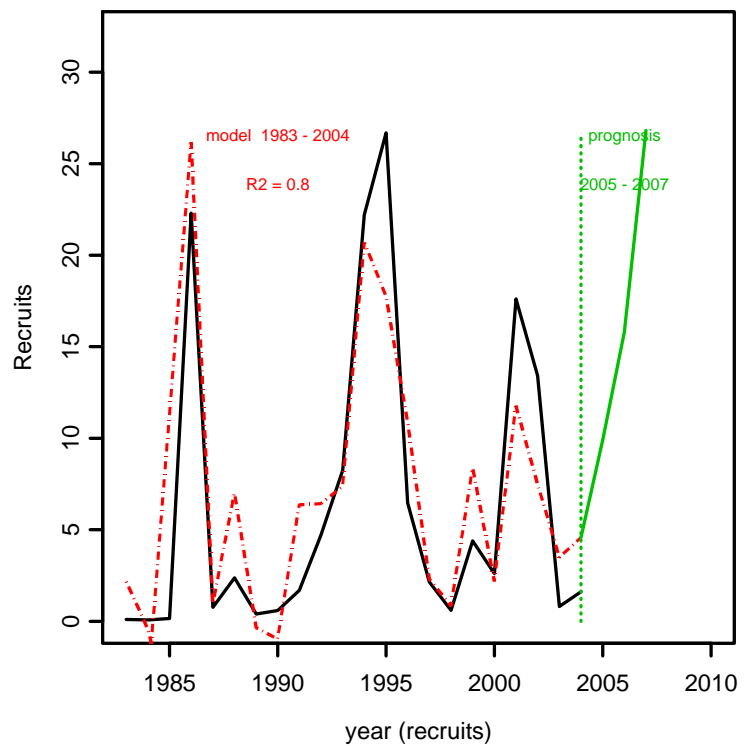

Figure 2.2.1.4. The figure shows the number of recruits (3 year olds) of Norwegian spring spawning herring (black) and the model fit (red), together with prognoses for 2005-2007 (green).

3 Norwegian Spring Spawning Herring

3.1 Stock description

3.1.1 General

The Norwegian spring spawning herring (*Clupea harengus*) is a highly migratory stock that is distributed throughout large parts of the NE Atlantic during its lifespan. It is a herring type with high number of vertebrae, large size at age, large maximum size, different scale characteristics from other herring stocks and large variation in year-class strength. The herring spawns along the Norwegian west coast in February - March. Large variations in the north-south distribution of the spawning areas have been observed through the centuries. The larvae drift north and northeast and distribute as 0-group in fjords along the Norwegian coast and in the Barents Sea. The Barents Sea is by far the most important juvenile area for the large year classes, which form the basis for the large production-potential of the stock. Some year classes are in addition distributed into the Norwegian Sea basin as 0-group. Examples of this are the 1950 and 2002 year classes. Most of the young herring leave the Barents Sea as 3 years old and feed in the north-eastern Norwegian Sea for 1-2 years before recruiting to the spawning stock. Large year classes typically mature at a higher mean age due to density dependent distribution and growth. However, exceptions occur and the 2002 year class is a large year class, which has shown quick growth and a relatively early maturation. Juveniles growing up in the Norwegian Sea have a quicker growth than the Barents Sea component resulting in approximately one year earlier maturation for this component. With maturation the young herring start joining the adult feeding migration in the Norwegian Sea. The feeding migration starts just after spawning with the maximum feeding intensity and condition increase occurring from late May until early July. The feeding migration is in general length dependent meaning that the largest and oldest fish perform longer and typically more western migrations than the younger ones. After the dispersed feeding migration the herring concentrate in one or more wintering areas in September-October. These areas are unstable and since 1950 the stock has used at least 6 different wintering areas in different periods. During the 1950's and 1960's they were situated east of Iceland and since around 1970 in Norwegian fjords. In 2001-2002 a new wintering area was established off the Norwegian coast between 69°30'N and 72°N. After wintering the spawning migration starts around mid January.

3.1.2 Changes in migration

A characteristic trait of the herring stock is an extremely plastic and varying migration pattern. The migration is characterised as relatively stable periods and periods characterised by large changes occurring at varying time intervals. The changes may or may not be correlated between the major distribution areas: Spawning, feeding and wintering. At present we see a period of large changes in both the wintering and feeding area. Until about 2002 the bulk of the adult herring wintered in fjords in northern Norway. The 1998 and 1999 year classes were expected to enter the fjords around 2002, but were instead observed wintering off the coast in the ocean off Vesterålen/Troms, between 69°30'N-72°N. This continued in the years to come and in 2005 also the 2002 year class was observed wintering in the same area. During these years, the amount of older herring wintering in the fjords has decreased rapidly and was down to about 700.000 tonnes during the winter 2005-2006 (12% of the estimated spawning stock in 2006). The survey covering the oceanic wintering area in November 2003-2005 have shown a strong decrease in the biomass in the wintering stock in the area, indicating that a third and so for unknown wintering area could be under establishment somewhere else. Such a development is supported by the western feeding distribution in recent years and the fact that the return migration of the smaller herring feeding in the west could be too long compared with comparable return migration distances observed in earlier periods. It is also supported by the fact that the International survey in May did not show any such negative trend in the stock.

With regard to the feeding area there has been a western trend, where the oldest and largest herring has been migrating further west in recent years. The plasticity of the herring migration could be regarded an adaptive trait enabling the stock to optimally exploiting the ever varying climate and planktonic resources of its potential range in the NE Atlantic.

During the autumn 2004 and 2005 Norwegian spring spawning herring has been caught as bycatch in smaller concentrations in catches of Icelandic summer spawning herring off the Icelandic east coast. This is a new trend probably linked to the western movement of the southwestern summer feeding area. The amount of Norwegian spring spawning herring wintering in this area is not known and no attempts have been done to estimate it so far.

3.2 ICES advice and management applicable to 2005 and 2006

EU, Faroe Islands, Iceland, Norway, and Russia agreed in 1996 to implement a long-term management plan for Norwegian spring-spawning herring. The management plan was part of the international agreement on total quota setting and sharing of the quota during the years 1997-2002. The plan consists of the following elements:

1. *Every effort shall be made to maintain a level of Spawning Stock Biomass (SSB) greater than the critical level (B_{lim}) of 2 500 000 t.*
2. *For the year 2001 and subsequent years, the Parties agreed to restrict their fishing on the basis of a TAC consistent with a fishing mortality rate of less than 0.125 for appropriate age groups as defined by ICES, unless future scientific advice requires modification of this fishing mortality rate.*
3. *Should the SSB fall below a reference point of 5 000 000 t (B_{pa}), the fishing mortality rate, referred under paragraph 2, shall be adapted in the light of scientific estimates of the conditions to ensure a safe and rapid recovery of the SSB to a level in excess of 5 000 000 t. The basis for such an adaptation should be at least a linear reduction in the fishing mortality rate from 0.125 at B_{pa} (5 000 000 t) to 0.05 B_{lim} (2 500 000 t).*
4. *The Parties shall, as appropriate, review and revise these management measures and strategies on the basis of any new advice provided by ICES.*

ICES considers that the objectives of this agreement are consistent with the precautionary approach.

In 2004 ACFM stated that: "Based on the most recent estimates of SSB and fishing mortality, ICES classifies the stock as having full reproduction capacity and harvested sustainably. The recruitment of the very strong 1992 year class led to an increase in SSB in 1997 to approximately 8 million t. Thereafter, SSB declined to just below 5 million t in 2001 and increased again to 7 million t in 2004. The year classes 1998 and 1999 are estimated to be relatively strong". The management plan implies catches of 890 000 t in 2005 which is expected to lead to spawning stock of 6.3 million tonnes in 2005.

For 2005 there was no agreement between the Coastal States regarding the allocation of the quota. The Norwegians rose their quota of 14% and following them up so did the Icelanders and the Faroese. The sum of the total revised national quotas for 2005 amounts to about 1 million tonnes.

In 2005 ACFM stated that " Based on the most recent estimates of SSB and fishing mortality, ICES classifies the stock as having full reproductive capacity and being harvested sustainably. The 1998 and 1999 year classes dominate the current spawning stock which is estimated around 6.3 million t. in 2005. The 2002 year class is estimated to be strong and will recruit to the fishery in 2006 and 2007. Preliminary indications show that the 2004 year class may also be strong." The management plan implies maximum catches of 732 000 t in 2006 which is expected to

lead to spawning stock of 7.7 million tonnes in 2007. Further ACFM considered that the absence of an international agreement on quota allocations in the two last years had led to an escalation in the fishing mortality exerted on the stock ($F_{2005} > F_{pa}$), with the fisheries in 2005 probably ending close to 1 million tonnes, over 100 000 tonnes more than the TAC recommended under the long-term management plan ($F=0.125$).

Since 2003 there has been no international agreement on adoption of the management plan, TAC and sharing of the quota. As a consequence the parties have allocated national quotas based on $F_{pa}=0.15$ rather than $F=0.125$ as agreed in the management plan. The sum of national quotas have in all years added up to somewhat more than the tonnage corresponding to the recommended F_{pa} . In retrospect the observed F has been below F_{pa} throughout the period 2003-2005 (Table 3.7.4.3).

In 2006, as in last three years, there was no agreement between the Coastal States regarding the allocation of the quota. Quotas were set unilaterally and in some countries quota were raised during the year. The sum of the total national quotas for 2006 amounts to about 967 000 t.

3.3 Description and development of the fisheries in 2005

The distribution of the fisheries of Norwegian spring-spawning herring by all countries in 2005 by ICES rectangles is shown in Figure 3.3.1 (total whole year) and in Figure 3.3.2 (by quarter).

Due to limitations by some countries to enter the EEZs of other countries in 2005 the fisheries do not necessarily depict the distribution of herring in the Norwegian Sea and the preferred fishing pattern of the fleets given free access to any zone.

A special feature of the summer fishery in 2005 was the prolonged fishery in the Faroese and Icelandic zone during summer, where the oldest age groups were present. The usual pattern has been that the fishery moved gradually northwards towards the Jan Mayen zone in June.

The migration pattern, together with environmental factors, was mapped in 2005 and 2006 during the ICES PGNAPES (Planning Group on Northeast Atlantic Pelagic Ecosystem Surveys) investigations (ICES 2005/D:09 and ICES 2006/RMC:09).

3.3.1 Denmark

The Danish fishery of Norwegian spring spawning herring is carried out by purse seiners (17,000 t.) and trawlers (5,000 t.). The fishery mainly took place in the second (14,000 t) and third quarter (14,000 t). Half of the landings were landed in Denmark (14,000 t.) and the other landings were landed at the Faroes, Iceland and in Norway. In 2005 the first fishing period started in the southern part of Division IIa in March (catch 2,700 t) and continued in May-June where app. 11,600 t was caught. Finally the landings from the third quarter were mainly taken in July and August.

3.3.2 Germany

The main fleet targeting pelagic species is based at Bremerhaven and Rostock. The vessels are owned by a Dutch company and operating under German flag. They consist of 3 large pelagic freezer trawlers of length greater than 90m up to more than 120m with hp between 4200 and 11000. The crew consists of about 35 to 40 men. The vessels are specially designed for pelagic fisheries. The catch is pumped into large storage tanks filled with cool water to keep the catch fresh until it is processed.

The German directed fishery for Norwegian spring-spawning herring fishery started in IIa in May and continued in IIa and b during summer until it ended in IIa in September. The total catches were 17,676 tonnes.

3.3.3 Faroe Islands

A special feature of the Faroese summer fishery for Norwegian spring-spawning herring in 2005 was the prolonged fishery in the Faroese zone during summer, relatively close to the isles, as well as in the Icelandic waters, where large (390-400g) herring was present. The usual pattern was that the fishery moved gradually northwards towards the Jan Mayen zone in June.

The Faroese fishery (8-10 large vessels and 2 smaller vessels) started in early May in the area north of the Faroes in the Faroese EEZ (Vb and IIa). In June the fishery continued north of the Faroes and also in the eastern part of the Icelandic waters. Later in June a fishery also developed in the Svalbard area west of the Bear Island. In July large catches were taken in the central and eastern part of the Faroese zone relatively close to the Faroes. Simultaneously a part of the fleet was operating in the Svalbard area and the northern part of the International zone. By early August the fishery in the Faroese zone ceased and continued in the International zone for the rest of the month and in September and October when the Faroese quota was finished, in total 65.071 tonnes.

The catch method has changed in 2005 with several vessels pair-trawling. About 44% of the catches were taken with pelagic pair-trawls, 48% with single pelagic trawls, and only 8% with purse seines.

3.3.4 Iceland

The Icelandic catch quota for Norwegian spring-spawning herring was set at 157,700 tonnes in 2005. The Icelandic fishery began in the first week of May in the western part of the international zone in the Norwegian Sea close to the Jan Mayen zone. Later in May the fishery moved gradually southwest into the Icelandic zone and to the border areas between Iceland-International waters and Faeroese zone. In the first three weeks of June the fishery was mainly conducted in Icelandic waters but at the end of the month a fishery started in the southern Spitsbergen zone. This fishery moved south-west and by the end of July had moved into the northern part of the international zone where most of the catches were taken during August and the first two weeks of September. In the latter half of September herring was caught both in the southern Spitsbergen zone and the northern international zone. In October the fishery moved into the international zone and later completely into the Icelandic zone east of Iceland where the Norwegian spring-spawning herring was mixed with the Icelandic summer-spawners. It was estimated that about 2 700 tonnes of NSSH were caught in autumn/early winter during the fishery for Icelandic summer-spawning herring.

The bulk of the catch was caught in May-June (47 000 tonnes) and July-August (72 000 tonnes). In September-October about 36 000 tonnes were fished. In November to the first half of December the catch was about 1 500 tonnes.

The total catch was 156 466 tonnes of which 140.500 tonnes were caught in mid-water trawl and the about 16 000 tonnes in purse-seine.

A total of 30 trawlers/purse-seiners participated in the herring fishery, as compared to 28 vessels in 2004. The length range of the vessels was 55-105 meters with a mean length of 67 meters. The engine power range of the fleet was 1325-5920 kW (1800-8051 HP) with a mean of 3125 KW (4246 HP). The average engine power has increased by almost 14% since 2004.

3.3.5 Ireland

No catches were taken by Ireland in 2005.

3.3.6 Netherlands

The Dutch fleet fishing for pelagic species in European waters consists of 14 freezer trawlers and one pair trawler. In addition, a number of flag vessels are operating from the Netherlands operating on foreign quota. Target species of this fleet are: herring, blue whiting, mackerel, horse mackerel and argentines. Some of these trawler also operate in west African waters during part of the year fishing for sardinella and horse mackerel. The fishery for Norwegian spring spawning is conducted using large pelagic trawls. Almost all herring catches originate from a directed fishery in the 3rd quarter of the year in ICES Sub-area II (International area in the Norwegian Sea). About 75% of the catches originate from this period. The remaining catch is taken in the 4th quarter. Since the Dutch quota is relatively small, the catches are taken in a few trips. In total 21,617 tonnes were taken by the Dutch fleet in 2005.

3.3.7 Norway

The Norwegian fishery is carried out by many size categories of vessels. Of the total national quota approximately 50% is allocated to purse seiners, 10% to trawlers and 40% to smaller coastal purse seiners. Due to the significant changes in the migration pattern of the herring recently there have been large changes in the fishing patterns of the Norwegian fleet as compared to the last years, in particular during the autumn season.

The fishing started just after New Year in the northern fjords and followed the southward spawning migration from mid January. The fisheries continued on the spawning grounds and ceased around March 1st with the deteriorating quality of the herring as the spawning progressed.

After the summer feeding the herring returned towards the Norwegian coast. Some herring entered the fjords (about 12% of the estimated spawning stock) while the rest wintered in high seas areas. Late incoming herring and small concentrations in the fjords as compared to the situation in later years characterized the autumn fishing season. After a period of fishing in the outer Vestfjord in late September-October the herring moved further into Ofotfjord and Tysfjord. At the same time the herring moved into the deep making the fisheries with purse seines difficult. As a result mainly the larger trawlers could make reasonable catches in the fjords. This was a new situation not experienced before and probably indicates a regime shift in the current Norwegian fisheries for herring. For a while the purse seine fleet searched in the ocean without finding significant concentrations. The 18th November the RV Johan Hjort reported about large schools just off the coast at about 70°N, which immediately triggered a large fishery. The fishery continued until Christmas when the quota was taken. The particular distribution of the herring this year disfavoured the smaller vessels.

Only negligible quantities (412 tonnes) were caught in the areas south of 62°N in 2005. Based on samples from these catches most of the herring belonged to local fjord herring stocks but is registered as NSSH in the statistical records. The same applies to some catches taken in more northern fjords during the oceanic summer feeding period of the stock.

The total Norwegian catch in 2005 was 580.804 tonnes, corresponding to 57.9 % of the total reported catch.

3.3.8 Russia

In 2005 the Russian fishery started within the shelf region of the Norwegian EEZ, near Trena Bank (approximately 65-66°N) in the beginning of February and Sklina and Buagrunnen Bank (approximately 63-65°N) in the end this month. In March the fishing was in progress in the same regions. In February and March the catch was 31 730 t. In May-June the commercial vessels conducted fishing in the northern part of the international area in the Norwegian Sea in region of the Polar Front and in the Jan Mayen area and Faroes FZ. In May-June the catch was 6 613 t. In July-September vessels caught herring in the international area in the Norwegian

Sea in the region of the Polar Front and the zone of Spitsbergen. In July-September the catch was 89 013 t. In the October the fishery of the herring were finished in the Norwegian EEZ. In October the catch was 7 743 t. The total Russian catch of Norwegian spring spawning was 132 099 tonnes.

The Russian fishery is carried out by many types of vessels, mainly trawls. The entire Russian catch was utilized for human consumption.

3.3.9 Sweden

Sweden caught 680 tonnes in 2005 in the southern part of International waters (Division IIa).

3.3.10 UK (Scotland)

No catches were taken by UK (Scotland) in 2005.

3.3.11 Poland

Poland took 561 tonnes in the northern part of International waters in late February 2005.

3.3.12 France

Information about French catches were delivered to the working group during the meeting. No catches were taken in 2005, but 400 t in 2004. These data were not used in the assesment.

3.4 Bycatches in the fishery

No information on bycatches in the fishery was supplied to the Working Group.

3.5 Fishery dependent data

3.5.1 Sampling intensity

Information on the sampling intensity for the age structure and weight at age in the catch is provided in Table 3.5.1.1. and Table 3.5.1.2. Most fisheries are covered by a biological sampling programme. The ageing of the age structure provided by the Netherlands and Denmark was presented up to a lower plus group as used in the assessment. Therefore these could not be used and an age structure for these countries has been borrough from other countries. The data has already been resubmitted from Denmark and will be resubmitted from the Netherlands to the Working Group with the full age structure next year.

3.5.2 Landings

Like in earlier years the fishing pattern in 2005 followed the clockwise migration pattern of the herring. There were significant changes in parts of the fishing pattern due to the ongoing changing migrations of the herring. As compared to last year, in particular two changes were noticeable: The westerly trend in the southwest area continued with more fish taken in the Icelandic zone as well as a prolonged summer fishery in the Faroese zone, and a shift from fjordic towards oceanic fisheries in northern Norway in the autumn. These two changes probably had the opposite effect with regard to selection pattern as a more western fishery will target the largest and oldest fish while oceanic fisheries in northern Norway will target younger fish than fjordic fishing (the oldest and outgoing year classes winter in the fjords). Still hardly any fishing took place in the Jan Mayen zone in 2005 since no coastal state agreement allowing non-Norwegian vessels to fish in the area had been reached.

The total annual catches of Norwegian spring-spawning herring for the period 1972–2005 (2005 preliminary) are presented in Tables 3.5.2.1 (by country).

The Working Group noted that in this fishery an unaccounted mortality caused by fishing operations and underreporting probably exists. In general, it was not possible to assess the magnitude of these extra removals from the stock, and taking into account the large catches taken in recent years, the relative importance of such additional mortality is probably low. Therefore, no extra amount to account for these factors has been added in 1994 and later years. In previous years, when the stock and the quotas were much smaller, an estimated amount of fish was added to the catches.

3.5.3 Discards

The Working Group has no accessible data to estimate possible discards of the herring. Although discarding may occur on this stock, it is considered to be a minor problem to the assessment.

3.5.4 Age and length composition of catches

To derive the age composition of the total international catches of Norwegian spring spawning herring in 2005 the program SALLOC (ICES 1998/ACFM:18) was used. Samples were provided from Denmark, Faroe Islands, Iceland, Norway, The Netherlands and Russia. Catch in numbers at age are computed with 15 as a plus group. In the samples from Denmark and the Netherlands the plus group was set at a lower age, so those samples were excluded. The data using the full age range were though made available at a later stage from Denmark. Unsourced catches were allocated to sampled ones with the knowledge of where and when the catches were taken. Striking is that no samples were taken in ICES area IIb, except length measurements by the Russian fleet. The allocations used and the results are shown in Table 3.5.1.1 and in WDs to the working group. The most abundant year class in the catches in 2005 was the 1998 year class (29%) followed with the 1999 year class (19%). The year class from 2002 represented about 13% of the catches and the one from 1992 about 10%. Other year classes were only minor in the catches. The catch in numbers are shown in Table 3.5.4.1.

After the Working Group meeting in 2005 it was noted that the catch derived by multiplying catch in numbers at age and mean weight at age produced by SALLOC with the 2004 data submitted to the data coordinator was about 250 thousand tons higher than the official catch. By examining the SAM.OUT file produced by SALLOC it was noted that the SOP for the catches for Denmark and Iceland were far too high, so it was obvious that something was wrong with the input data. Right after the Working Group meeting there were made some temporary adjustments of the catch in numbers (without running SALLOC again) and they used in an assessment, which was regarded as a final one in 2005. Before the WGNPBW meeting in 2006 revised data was made available. Allocations were made anew and the program SALLOC used to derive age composition of the total international catches of Norwegian spring spawning herring in 2004. The results were submitted to the working group in a working document. The catch in number for 2004 are given in Table 3.5.4.1. The most numerous year class in the catches in 2004 was the 1998 year class (29%) followed by the 1999 year class (18%) and the 1992 year class (16%).

After the Working Group meeting in 2005 it was also noted that the catch in numbers for 2003 were wrong, but to a much lesser degree than the 2004 data. By using revised data and correcting an allocation new catch in numbers were derived. The results were submitted to the Working Group in a working document. In 2003 the 1998 year class was most abundant in the catches (28%), followed by the 1992 year class (22%) and the 1999 year class (12%). The new derived catch in numbers are shown in Table 3.5.4.1.

The recalculated catch in numbers for 2003 and 2004 as well as the ones for 2005 were used in stock assessment of the Norwegian spring spawning herring stock.

Data on the combined length composition of the 2005 commercial catch by quarter of the year from the directed fisheries in the Norwegian Sea were provided by Faroe Islands, Norway and Russia. Length composition of the herring varied from 17 to 41 cm, with 87% of fish ranging from 29–37 cm. (Table 3.5.4.2).

3.5.5 Weight at age

The weight in catches in 2005 was taken from the total international weight-at-age (Table 3.5.5.1), which were produced using the computer programme SALLOC, standard ICES software. Long term trends in weight at age are presented in Figure 3.5.5.1. Long term changes in weight at age have been observed in the past. Weights were very high in the early eighties and low in the period before. There appear to be year effects and cohort effects. These have not been investigated further in this meeting. In recent years the weight at age is at an average level with a slight increasing trend. For younger age groups (ages 0-3), the catch weight at age show a different trend with relative high levels in recent years. The changes observed in these age group are thought to reflect mostly a change in selectivity in the fleet. The catch weight at age matrix presented in previous reports contained assumed values for age groups for which there are no catch number. These values have been removed in this year's table.

Weight at age in the stock for 2006 (January 1st) (Table 3.5.5.2) was taken from Norwegian samples taken in the wintering areas in December 2005. No changes were made in weights in previous years. Trends in weight at age in the stock are given in Figure 3.5.5.2. The weight at age of the stock from the eighties onwards for the older age groups originate from surveys carried out in the wintering areas. In the period before 1980, in the absence of observations, assumptions have been on the stock weights for most age groups. These are documented in Toresen and Østvedt (2002)¹. In the absence of observations, weight at age for the younger age groups are based on expert judgement.

3.5.6 Length at age

Length at age data are available from several countries. They are not used in the assessment.

3.5.7 Maturity at age

Except for year class 2002, for the maturity at age in the last 10 years, in general, the same values have been used each year.

Maturation of the 2002 year class: As reported in last years report (section 3.5.7) the 2002 year class has a higher growth rate than usually seen in large year classes of this stock. One reason to this is that part of the juveniles had the Norwegian Sea as the juvenile area, favouring quicker growth than in the Barents Sea.

The proportion mature as 4 year old were calculated from samples collected during the surveys in the wintering area in November 2005 (age 3, before spawning) and in the Norwegian Sea in May 2006 (age 4, after spawning). The proportion of fishes in maturation stage 3 or larger (fish to spawn) in November 2005 was used as a first proxy to the proportion maturing. The proportion maturing according to these data was 0.85. The proportion in stages >5 (spent) in May were used as a proxy for the proportion having spawned. The proportion having spawned according to these data were 0.92. Based on these observations and calculations 0.9 was adopted as proportion mature of the 2002 yearclass at age 4. Based on this 1.0 instead of 0.9 was adopted as proportion mature of the 2002 year class at age 5 in the

¹ Variation in abundance of Norwegian spring-spawning herring (*Clupea harengus*, Clupeidae) throughout the 20th century and the influence of climatic fluctuation. Fish and Fisheries. 2000, 1 231-256

predictions. All other year classes in the later years were set at the standard 0.3 at age 4, 0.9 at age 5 and 1.0 at age 6 both in the assessment and predictions. The maturity ogives for the later years should be revised as the current ones used do not reflect the actual variation in this parameter. The Working Group judge the present values as acceptable but with potential for improvement.

Proportion mature at age is shown in Table 3.5.7,1 and proportion mature used in predictions in Table 3.9.1.1.

3.5.8 Natural Mortality

No changes were done to the applied natural mortalities, 0.9 for 0 to 2 years old, 0.15 for 3 years and older. The values $M=0.9$ for ages 0-2 were based on a comparison between estimates of young herring in the Barents Sea from acoustic observations and estimates of year class strength from the assessment at older age. The value of 0.9 is an average over the juvenile period. The method and the rationale are explained in an earlier WG report.

3.6 Fisheries independent data

3.6.1 Survey abundance indices

Eight surveys directed to Norwegian spring spawning herring have been continued and four new survey abundance indices were used in the assessment. Survey indices from past surveys for different periods were also used in assessment. The criteria for the selection of data are briefly described in the following paragraphs.

3.6.1.1 Spawning grounds

3.6.1.1.1 Acoustic survey on spawning grounds in February March (survey 1)

In 2006 a Norwegian acoustic survey was undertaken to estimate the abundance of herring in the spawning areas in February and March. The survey is carried out since 1988 but not in every year. An estimate was not used for the 2006 assessment because of the poor coverage of the survey in the northern spawning area (Table 3.6.1.1.1 and Figure 3.6.1.1.1). The age groups 5-15+ are used in the assessment. The year 1988-1990 are not used in the assessments.

3.6.1.2 Wintering areas

The wintering areas of herring have been monitored acoustically in November/December (1992-present) and in January (1991-1999) by Norway. The wintering area of herring started to change in 2003. During the December survey in 2003 the RV Johan Hjørt observed concentrations of herring in oceanic waters off Vesterålen and Troms for the first time since the surveys started. In 2006, as in 2005, a survey covering both the fjords and oceanic wintering areas was carried out. See section 3.1.2 for a closer description of the changes in the wintering area of the herring stock.

3.6.1.2.1 Acoustic survey in November/December (survey 2)

The survey is carried out by Norway since 1992 in the Norwegian fjords where the adult herring overwinter. Since 2004 also the Norwegian coast is included in the survey to take account of changes in the overwintering area. In 2006 the RV G.O.Sars carried out an acoustic survey in the fjordic and oceanic wintering area in northern Norway (Figure 3.6.1.2.1). The results of this survey are shown in Table 3.6.1.2.1. This survey covers the known wintering area of the mature part of the stock. There was a very distinct difference in age structure between the two areas. Most of the 1998, 1999 and 2002 year classes are wintering in the oceanic areas with the rest of the older year classes wintering in the fjords.

The survey has shown a strong negative trend in the development of the 1998 and 1999 year classes since 2003. The decrease of these year classes is far outside the range seen in other surveys later in the year and is not considered to be reflecting the abundance. Given the large changes in wintering pattern of the herring and the possibility of a third and undescribed wintering area, it was decided not to use this survey for the period following the new wintering pattern of the herring in the assessment. The survey should be reintroduced in the assessment as soon as possible after the new wintering pattern of the herring has been described and accounted for in the survey strategy.

For this reason the surveys from 2002-2006 were not used in the assessment. The age groups 4-15+ for the other years are used in the assessment.

3.6.1.2.2 Acoustic survey in January (survey 3)

This survey was carried out by Norway in the fjord in the period 1991-1999. The results of the survey in the wintering area in January can be found in Table 3.6.1.2.2. Although the survey series has ended the data are still used in the assessment. The age groups 5-15+ are currently used.

3.6.1.3 Feeding areas

The main feeding has taken place along the polar front from the island of Jan Mayen in a northeasterly direction towards Bear Island. During the latter half of the 1990s there has been a gradual shift in the migration pattern with the herring migrations shifting north and eastwards. In 2002 and 2003 this development seems to have stopped and the herring had a more southerly distribution at the end of the feeding season. This southwestwardly shift has continued in 2004, 2005 and especially in 2006, when the fishery has continued in the southwestern areas throughout the summer.

3.6.1.3.1 Ecosystem survey in the Norwegian Sea (survey 5)

Since 1995, the Faroes, Iceland, Norway, Russia (except in 2006), and the EU, since 1997 (except in 2002 and 2003) have coordinated their survey effort on these and the other pelagic fish stocks in the Norwegian Sea in May. The survey is coordinated by PGNAPES.

As in 2005, the internationally coordinated survey in May was carried out with six vessels, one from the Denmark (EU coordinated), one from the Faroes, one from Iceland and two from Norway. The survey coverage was somewhat more extensive than in previous years, especially off NE-Iceland and in the eastern Icelandic Sea.

Herring were recorded throughout most of the survey area, as shown in Figure 3.6.1.3.1. The distribution was in many ways similar to that of 2005. The lowest concentrations were recorded in the central Norwegian Sea, with the highest values in the Faroese EEZ and at the eastern edge of the cold waters of the East Icelandic Current. High concentrations were also recorded in the easternmost Norwegian Sea, between Bear Island and the north coast of Norway, as well as northwest of Lofoten.

The amount of herring in the westernmost area was considerably higher in 2006 than in 2005. The reasons are probably twofold. There were especially good weather conditions in 2006 and the large numbers (biomass) of the 2002 year class are in the process of migrating west out of the Barents Sea. The total acoustic herring estimate from the Norwegian Sea in May 2006 is 8.3 million tonnes. The details of the estimate are given in Table 3.6.1.3.1. A complete herring data set is found in the PGNAPES reports from the years 1995-2006 at www.imr.no/PGSPFN. The age groups 3-15+ are used in the assessment 2006.

3.6.1.4 Nursery areas

The nursery areas of the Norwegian spring-spawning herring are in the Norwegian fjords and coastal areas, and in the Barents Sea. Since 1988, when the 1983-year class spawned for the first time, the latter area has increased in importance as a nursery area for herring. The 2002 and 2004 year classes are in addition, distributed into the Norwegian Sea basin as 0-group.

3.6.1.4.1 Barents Sea May/June recruitment survey (west from 20° E) (survey 4)

Recruitment surveys in the Barents Sea have been conducted in the Norwegian and Russian Sea in May-June since 1991. In 2005 this survey became part of the ecosystem survey (see section 3.6.1.3.1). The results are given in Table 3.6.1.4.1. No surveys were carried out in the years 2003-2004. The age groups 1 and 2 are used in the assessment.

The plan was to cover all of the relevant parts of the Barents Sea, as was done in 2005 and to include all of the immature part of the stock. Unfortunately, due to technical and administrative difficulties, the Russian EEZ could not be surveyed in May 2006. As result only the immature herring in the areas east to the Russian EEZ were covered.

Young herring were observed throughout the surveyed area in the Barents Sea with the largest concentrations found in the westernmost area around 20°E and in the eastern areas along the Norwegian-Russian EEZ border. The Russian zone was not covered and the estimate of young herring is a definite underestimate, in particular with regard to the 2004 and 2005 year classes.

The herring in the Barents Sea was composed of four year classes 2002, 2003, 2004 and 2005. The 2004 year class was by far the most dominant year class and constituted approximately 75% of the herring tonnage east of 20°E. The survey indicates that this is a strong year class with 35 billion individuals in the Barents Sea, but with the important Russian zone not covered a trustworthy evaluation is not possible. The same applies to the 2005 year class. The 2003 year class seems weak with only 5 billion individuals.

3.6.1.4.2 Barents Sea August/September recruitment survey (survey 6)

In 2001, the Working Group decided to include data on immature herring obtained during the Russian-Norwegian survey in August-October in estimating the younger year classes in the Barents Sea. The results from these surveys are given in Table 3.6.1.4.2. The majority of fish (about 67 % by number) were from the 2003 year class. According to these results, the 2001 year class has left the Barents Sea and was found during the Norwegian Sea survey. Incompatibility between age 2 in this year and age 1 in the previous year may be explained by the underestimation of young herring (below 12 cm length) in 2004. The distribution of young herring is shown in Figure 3.6.1.4.1. According to this distribution, herring can be divided into east and west components. Eastern juvenile herring with a predominance of 1 year olds were distributed over a large area between 25° and 44°E and up to 75°N. West of 25°E 3 year olds and older herring dominated. Aggregations with the highest density of young herring were recorded in the southern part of the sea between 32° and 43°E. Further east of 46°E, as in 2004 there were no registrations found east of 46°E. The age groups 1 and 2 are used in the assessment.

The results from the joint Norwegian-Russian 0-group survey in the Barents Sea are given in Table 3.6.1.4.3 and the distribution area in Figure 3.6.1.4.2. Abundance of 0-group herring is much lower than in 2004 and slightly below the average level for the period 1980-2005. Dense concentrations were found in a small area in the central Barents Sea and there was only one catch southwest of Spitsbergen. The distribution area in the central Barents Sea and west of Spitsbergen has slightly decreased compared to last year. Only patchy distributions were observed to the east and along the coast.

The log index has been used in the assessment up to 2004 and then replaced by a new Herring abundance index, which was used in the 2006 assessment. Details of these indices are given in Table 3.6.1.4.2.

3.6.1.4.3 Coastal Norwegian Acoustic 0-group herring survey (survey 7)

The results from the 0-group herring survey in Norwegian fjords and coastal areas are given in Table 3.6.1.4.3. The surveys are carried out by Norway since 1975. However, the data are not used in the present assessment of herring because a new survey design was introduced in 2003.

3.6.1.5 Herring larval surveys

3.6.1.5.1 Herring larval survey on the Norwegian shelf (survey 8)

A Norwegian herring larval survey has been carried out on the Norwegian shelf since 1981 during March-April. The objectives of the survey are to map the distribution of herring larvae and other fish larvae on the Norwegian shelf and to collect data on hydrography, nutrients, chlorophyll and zooplankton. The larval indices are used as indicator of the size of the spawning stock. Two indices are available from this survey (Table 3.6.1.5.1). The "Index 1" is used in the assessment.

The survey in 2006 started in Bergen and continued until the northern limit of the larval distribution was found at the inner part of Tromsøflaket. During the survey a total of 169 CTD and larval stations were conducted using a Gulf III sampler (375 µm). Most of the larvae were in early first feeding stages and very few older larvae were found.

The herring larvae were observed throughout the sampling area. However, zero values were found both on the northernmost section near Fugløya and on the southernmost station near Stad. Since there have been very limited spawning activity on the traditional spawning grounds south of Møre (i.e. Karmøy) the later years, it was concluded that the survey covered the total distribution area of herring larvae (Figure 3.6.1.5.1). The distribution this year was somewhat different from last year. Last year the highest concentrations were found in the Haltenbanken and Sklinnabanken area while this year the highest concentrations were observed just north of the Møre spawning grounds and very few larvae were found on Haltenbanken indicating that there was only limited spawning activity on this bank in 2006. Relatively high concentrations of larvae were also found south of Vestfjorden while no larvae were observed on three stations inside Vestfjorden. On most of the sections the western limit of the herring larvae distribution was found.

3.6.2 Tagging data

With the exception of 1999, 2001 and 2005, tagging has been carried out annually since 1975. The tagging experiments in 2006 were carried out in March-April along the Norwegian coast from 64°N-68°N where a total of 32 150 herring were tagged. During the tagging process, the length of each tagged herring is measured. For each purse seine catch that is used for tagging, a sample of 100 fish is taken to determine the age distribution within each length group. The age composition of tagged herring in this batch is then estimated from the age distribution in the sample.

Recovery of tags from supervised detector plants has continued, as well as recovery from the standard magnets in the production line of fish processing plants and from individuals. For stock assessment purposes, tags are only used from supervised detector plants where detector efficiency has been tested, and where it is known that the detectors have been working as intended. Three factories filled these criteria in 2005, and a total of 68.2 million herring were screened in these factories. Magnet efficiency was close to 100% in 2005. All tagged herring recovered were sent to the Institute of Marine Research, Bergen, where they were measured,

weighed and aged. In 2005, 78 tags from herring that were four years or more when tagged, were recovered from the factories (Table 3.6.2.1.).

The use of the tagging data was discontinued in the current assessment of the herring stock due to a low number of recaptures. This comes as a result of too low tag density in the stock given the stock size and number of fishes screened. See section 3.7.2.1 for further description and discussion on this theme. It should be mentioned that the removal of 2 tags in the exploratory assessment runs changed the size of the spawning stock with approximately 2 million tonnes.

3.7 Stock Assessment

Stock assessments were carried out with Adapt, SeaStar and ISVPA. In addition catch curve analyses was carried out.

3.7.1 Catch curve analyses

Catches

Figure 3.7.1.1. shows age disaggregated catch in numbers of Norwegian spring spawning herring plotted on a log scale. For comparison lines corresponding to $Z=0.4$ are drawn. How to interpret such curves is difficult. The figure indicates that year class 1991 has been decreasing in numbers at a rate close to $Z=0.4$, but year class 1992 at lower rate than 0.4. This interpretation is dependent on the fishing effort being relatively constant in recent years. Gradually increasing fishing effort makes the slopes lower than the real value of Z . Using the same logic as before than the figure indicates that year classes 1998 and 1999 are still not fully recruited to the fishery. Another message could be that year classes 1992 to 1997 have been disappearing from the catches at a lower rate than 0.4 since the year 2002. This figure gives no information on year classes 2000 and younger.

Surveys

Similar figures were also made for age disaggregated abundance indices from the acoustic surveys, see Figures 3.7.1.2 - 3.7.1.5. Only few points are available for each year class in the spawning survey in February-March (Figure 3.7.1.2), but the last two points for year classes 1991 and younger show a huge drop, which supports the statement that the survey has not covered the whole stock. Figure 3.7.1.3 shows the indices from the acoustic survey in the wintering areas in November-December. It indicates that the 1991 and 1992 year classes have been disappearing at a rate close to Z of 0.4. Eye-catching are the low values for the 1998 and 1999 year classes at age 4 and 3 correspondingly in 2002. These are due to the fact that in 2002 these year classes did not overwinter in the Fjord system as the older part of the stock did, but resided outside in the ocean and were not covered by this survey. This figure also indicates that the 1998 and 1999 year classes are disappearing at a rate much higher than 0.4 in this survey which contradicts to what is seen in the catches. A possible explanation is that the stock has not been covered by the survey. In Figure 3.7.1.4 the indices from the survey in the wintering areas in January are shown. This survey has not been conducted since 1999. The age disaggregated abundance indices from the international survey in the feeding area are shown in Figure 3.7.1.5. At large they tell a similar story as is drawn from the catches.

3.7.2 Data Exploration with assessment models

3.7.2.1 Data Exploration with Sea Star

In SeaStar assessments the catchabilities of the acoustic surveys are assumed to have no age structure, i.e. no age or abundance dependence. The reason for this choice is that the mechanism for the recruiting of herring to the surveys is that of migration, not of growth, where the latter process could be assumed to be more regular and modellable. Instead, for each

survey there is set a minimum age for inclusion of each year class. However, one needs to be cautious, since the different year classes may have different recruitment ages to the surveys. An important example is the failure of the 1998 year class to recruit fully to the December survey in 2002, for which reason the WG meeting 2003 considered this data point an outlier. In the coming years special attention should be paid also to the large 2002 year class, where a substantial part grew up in the Norwegian Sea instead of in the Barents Sea.

The estimation of parameters is based on maximising a log-likelihood function. The uncertainty of the input data is estimated along with other parameters. Thus, there is no need for a subjective weighting of each source of input data – the weight the data get in the estimation is determined by the uncertainty in the data. The uncertainties in the acoustic surveys on the adult stock is described with a common parameter, as previous experiments has shown that using separate uncertainties for these stocks does not change the estimate appreciably.

The input data used are:

Numbers at age in the catch	Table 3.5.4.1
Weight at age in the stock	Table 3.5.5.2
Proportion mature at age	Table 3.5.7.1
Acoustic surveys	Table 3.6.1.1.1, 3.6.1.2.1, 3.6.1.2.2, 3.6.1.3.1, 3.6.1.4.1, 3.6.1.4.2
Tag data	Table 3.6.2.1
Larval data	Table 3.6.1.5.1 (Index 1)
0-group data	Table 3.6.1.4.2

The formerly used logarithmic 0-group time series has been replaced by a new 0-group time series, see section 3.6.1.4.2.

This year not only new recovery data (for 2005) are used, but also recoveries from a new tagging experiment in 2002. Tagging data for year classes 1993 and older are used in the data explorations.

The larvae observation in 2003 in survey was deleted at the WG group meeting in 2003 and has not been used since then in assessments.

The acoustic surveys used are (the numbering is used elsewhere in the text of this section):

1	Spawning grounds along the Norwegian coast	Minimum age: 5
2	Wintering area in Vestfjorden in November-December	Minimum age: 4
3	Wintering area in Vestfjorden in January	Minimum age: 5
4	Young herring in the Barents Sea in May	Ages 1 and 2
5	Feeding areas in the Norwegian Sea in May	Minimum age: 3
6	As part of the joint IMR-PINRO ecosystem survey in August-September	Ages 1 and 2

It is assumed that the distribution of the main tuning series of older fish follows a gamma distribution with a common CV, which is estimated, and that the distribution of the acoustic data in the Barents Sea follows a lognormal distribution. The tag return data are assumed to follow a Poisson distribution, which is commonly used for rare events, the larval data are assumed to follow a gamma distribution with an estimated CV and the zero group data are assumed to follow a lognormal distribution with an estimated standard deviation.

Previously it has been observed in this WG that as the 1983 and 1985 year classes grew older than about 13 years the age readers tended to transfer fish from the 1983 to the 1985 year class. This is corrected for in the SeaStar software by moving fish from the 1985 year class to

the 1983 year class in the catch and surveys so that the ratio between these year classes before age 13 is maintained also for older ages.

Problems with the acoustic survey data

In recent years there has been an increasing trend of the stock overwintering outside of the traditional (after the collapse) overwintering areas in Vestfjorden. This is reflected in the trend in the survey indices. Figure 3.7.2.1.1 shows the survey indices together with the assessment using the same settings as in 2005 (Run 10 below), see 2005 settings in Table 3.7.2.1.1. It is seen that the trend in the wintering survey (survey 2) for the 1998 and 1999 year classes is a much faster decline than that seen in the assessment, in contrast to survey 1 (spawning areas) and particular survey 5 (Norwegian Sea), where the decline in the survey index matches the decline in the assessment, once the year classes are fully recruited to the survey.

The WG felt that this is due to the migration pattern around the wintering areas, which is not taken into account in the observation model. It was therefore decided to exclude the years 2002-2005 from survey 1 in the further analysis.

Based on a map of survey tracks it was also decided to delete the 2006 spawning stock survey from the analysis. The spawning stock is poorly covered and in this year the survey therefore has not sufficient quality to be included.

Problems with the tag data

An exploratory run where the recovery data in 2004 and 2005 for the 2002 release for the 1991 year class were removed (2 data points with one tag in each) gave a change in perceived spawning stock of about 2 million tonnes. Also, exploratory runs (Table 3.7.2.1.2) revealed unstableness connecting to the tagging data, and the tagging data gave an opposite view of the stock with respect to the surveys than in previous years. The WG felt for these reasons that the level of tagging may be inadequate and pending further investigations into the use of these data decided not to use tagging data this year.

Problems with the larval data

In 2005 and previous years it has been assumed that the expected value of the larval observations is proportional to the spawning stock. This has yielded a systematically too low expectation in recent years. This year the following model was used:

$$l = \frac{a \times S}{1 + e^{b \times (c - a \times S)}}$$

Where:

- l = expectation value for the larval data
- S = spawning stock from the VPA
- a, b, c = parameters to be estimated

This is an increase in number of parameters by 2. Figure 3.7.2.1.2 shows a comparison of fits for runs with and without this amendment. Table 3.7.2.1.2 (run 1 vs run 4) shows that this amendment increased the total likelihood by considerably more than 2, which shows that the improvement is significant by the Akaike information criterion. Also, the fit to the survey data gets somewhat better with this amendment.

Comparison with the 2005 assessment

With the same settings as used in the 2005 assessment (SPALY), except for the change of 0-group index and amendments of catch data, the spawning stock in 2006 is estimated at 12.64

million tonnes as compared to a value expected last year of 6.67. The spawning stock in 2006 with the final assessment this year is estimated at 10.63 million tonnes, an increase of about 4 million tonnes with respect to what was expected in 2005. The large increase in the spawning stock is primarily due to earlier and almost full maturation of the 2002 year class in 2006.

The SeaStar final run

Figure 3.7.2.1.3 shows the fit to survey data for the main SeaStar run. Except for the recruitment of the 1991 year class to survey 2 (wintering areas) and the 1998 and 1999 to survey 5 (Norwegian Sea) there seems to be a good correspondence between the historic perception of the stock and the survey indices on the adult stock. In the Barents Sea the survey indices are generally high as compared to the stock estimated in the assessment. Figure 3.7.2.1.4 shows the quantile-quantile plot that shall be a straight line if the data meet the model's assumptions on the error distribution. This diagnostic shows that the data meet the assumptions fairly well, although the deviations should be investigated. Figure 3.7.2.1.5 shows the retrospective plot. The development of the spawning stock is fairly consistent the latest years, but earlier the retrospective runs give an overestimate. The catchabilities are converging. Table 3.7.4.3 gives the historic summary.

3.7.2.1.1 Alternative settings

The settings used in the present assessment are shown in Table 3.7.2.1.1, where the settings used in 2005 are given for comparison.

As has been the case during previous assessments of Norwegian spring spawning herring with SeaStar, a number of exploratory runs were performed to see the effect of various options and settings. These runs were:

Run number	Explanation
Run 1	See settings in Table 3.7.2.1.1
The other runs are deviations from Default:	
Run 2	Survey 2 in 2002 was used
Run 3	Survey 1 in 2006 was used
Run 4	The proportional larval observation model was used
Run 5	Tag data was used
Run 6	The larval data were not used
Run 7	The zerogroup data were not used
Run 8	M was estimated, both for young and adult herring
Run 9	The gamma distribution was replaced with the lognormal distribution for survey errors
Run 10	Settings as in 2005, but using the new zerogroup index
Run 11	Settings as run 11, but without tag data
Run 12	Settings as run 11, but without larval data

The information provided in Table 3.7.2.1.2 is stock biomass, survey catchabilities natural mortalities and log-likelihood for the survey and larval terms in the likelihood function. The stock biomasses give an impression of the effect of the settings, the catchabilities show how well the surveys agree with the stock history from the tuning and the log-likelihoods indicate how well the data are described by the model. It should be noted, however, that a direct comparison of log-likelihoods can only be made between runs having the same number of data points for the part of the likelihood in question.

During the meeting it was decided to adjust the proportion mature at age in 2006 and there was not time to rerun the exploratory runs, only the main run. The new values for the proportion mature at age was used to recalculate the spawning stock in 2006. However, the value of the spawning stock affects the assessment through the use of the larval data. Therefore, the from the values of the spawning stock in Table 3.7.2.1.2 there should be subtracted 0.5 million tonnes.

For the surveys along the Norwegian coast and in the Norwegian Sea the catchabilities lie between 0.5 and 1.0, which also has been the case in previous assessments, i.e. the surveys are slight underestimates of the stock with respect to the assessment. The Norwegian Sea survey (S5) has catchabilities that in most cases are the closest to 1. The Barents Sea surveys have catchabilities about 0.3 and therefore give a lower impression of year class strength than the surveys on the adult stock.

When the tag data are used the perceived spawning stock in 2006 becomes appreciably higher, in contrast to previous years where the tag data tended to decrease the stock (run 1 vs run 5). The same influence of the tag data is seen in the runs with settings for the acoustic data as were used in 2005 (run 11 vs run 12).

If the larval data are removed from the assessment the SSB is decreased by about one million tonnes (run 1 vs run 6), similar decreases have been the case the previous years. However, the decrease is much larger with the 2005 settings (run 10 vs run12), which probably is connected to the linear observation model used. Using the linear observation model on the present settings will increase the spawning stock considerably.

Using a lognormal distribution instead of a gamma distribution for the error distribution of surveys on the adult stock did not change the perception of the stock appreciably.

In previous WG meetings it has been possible to estimate the natural mortality, although with a decreasing trend. At this meeting the estimate of natural mortality failed.

3.7.2.2 Data Exploration with ISVPA

One of the historical objections against the application of separable models like ISVPA to NSS herring stock assessment was that the assumption about the selection pattern stability can be violated by systematic effects of higher or lower availability to the fishery of different year classes (generations). Such an effect can originate from changes in the spatial distribution of very abundant or poor generations, from higher attitude to fish more abundant schools composed of more abundant year classes, or caused by any other reasons, like errors in aging, etc.

This year a new version of the ISVPA model named Triple Instantaneous Separable VPA (or TISVPA) was applied. The model is constructed as an extension of the ISVPA model (of its version 2004.3, first presented at the ICES Study Group on Assessment Methods Applicable to Assessment of Norwegian Spring-Spawning Herring and Blue Whiting Stocks (ICES, 2004)). Detailed algorithm is given in (Vasilyev, WD). In a few words, the model now can represent fishing mortality coefficients (more precisely – exploitation rates) as a product of three parameters: $f(\text{year}) \cdot s(\text{age}) \cdot g(\text{cohort})$. Different ways of normalization allow to get sub-models of two mechanisms of changes in selection pattern (or two sub-versions with respect to g-factors):

- 1) model of “within-year effort redistribution by ages” (normalization of $s(a,y) = s(a) \cdot g(\text{cohort})$ to 1 by sum is hold for each year)
- 2) model of “gain (loss) in selection” (only $s(a)$ are normalized to 1 by sum, but not $s(a,y)$).

The first sub-model assumes that in each year more fishing-attractive cohorts borrow some amount of fishing effort from other cohorts by increasing its selection at the expense of diminished selections for other age groups in this year. The second one assumes that some cohorts has increased (or reduced) selections, but it does not cause direct change in selections for others. Preliminary experiments showed that the sub-model 1 gave better fit to NSS herring data and just this version was applied by WGNPBW.

An additional normalization (matrix of all g-factors is normalized to 1 by average, for details – see Appendix in working document) is used in the model to balance the model parameters estimation procedures.

In the model the generation-dependent g-factors can be applied not to all age groups, but to some age “window”. This helps (1) to be closer to real situations (when it is known that only some range of age groups have peculiarities in their distribution) and (2) to diminish the influence of age groups having data of lower quality (usually the youngest and oldest ages). For age groups which are outside the chosen age range, the g-factors are equal to 1, but in fact, as a result of global normalization of all g-factors to unit by average, they can get somewhat different values. For NSS herring the age range for estimation (and application) of g-factors giving the best fit was found to be 4-8.

Other model setting were used similar to what was used before: the catch-controlled version of the ISVPA with constraint of unbiased model approximation of logarithmic catch-at-age.

ISVPA (TISVPA) settings in 2005 and 2006

	2005	2006
Model version	ISVPA (version 2004.3)	TISVPA (version 2006.1)
separable constraint	traditional, all years and ages (1950-2005; 1-16+)	Triple (including generation dependent factors) for ages 4-8 and traditional for other ages (1-3 and 9-16+); sub-model of “within-year effort redistribution”; years of analysis: 1986-2006
constraint on bias	unbiasedness of the model approximation of logarithmic catch-at-age	the same
What was minimized for catch-at-age?	The median of distribution (MDN) of squared residuals in logarithmic catch-at-age	Absolute median deviations (AMD) - the median of the distribution of absolute deviations of residuals in logarithmic catch-at-age from the median value of logarithmic residuals.
Survey 1	data range: 1991-2005; minimization of MDN for log-abundances; q were estimated	data range: 1991-2005; minimization of MDN for log. age proportions; q were estimated
Survey 2	data range: 1992-2004; minimization of MDN for log.abundances; q were estimated	data range: 1992-2001; minimization of AMD for log. abundances; q were estimated
Survey 3	data range: 1991-1999; minimization of AMD for log-abundances; q were estimated	data range: 1991-1999; minimization of AMD for log. abundances; q were estimated
Survey 4	data range: 1990-2002; minimization of AMD for log-abundances; q were estimated	data range: 1990-2006; minimization of AMD for log. age proportions; q were estimated
Survey 5	data range: 1996-2005; minimization of MDN for log. age proportions; q were estimated	data range: 1996-2006; minimization of AMD for log. age proportions; q were estimated
Survey 6	data range: 1990-2004; minimization of MN for log-abundances; q were estimated	data range: 1990-2005; minimization of MDN for log-age proportions; q were estimated

Profiles of components of the ISVPA loss function for different sources of information are presented in Figure 3.7.2.2.1. On the Figure they are compared to those coming from “ordinary” ISVPA. For TISVPA, the minimum for catch-at-age data is much more clear than to ISVPA.

Figure 3.7.2.2.2 presents the model residuals in logarithmic catch-at-age and in surveys. As it can be seen, the TISVPA residuals cohort structures in residuals for catch-at-age are strongly reduced by including the g-factors in the model. For survey data there are no apparent changes in residuals.

Estimates of generation-dependent factors and the selection matrix are shown in Figure 3.7.2.2.3. Figure 3.7.2.2.4 gives a comparison to the results of previous stock assessments by means of ISVPA. As it can be seen, the tendency of the stock to increase after 2001 was detected properly already in 2004 assessment when terminal year of data was 2003. Because in fact the data were changed from year to year (different points in surveys data were excluded in different years) and because of changes in amount of information in data sets different

model options with respect tuning on surveys could be preferable in different years. That is why actual past assessment results can differ and can be sometimes better than the results of “mechanistic” retrospective runs (Figure 3.7.2.2.5). Figure 3.7.2.2.6 represents the results of bootstrap. Conditional parametric bootstrap was used for catch-at-age and lognormal noise with $cv=0.3$ was added to survey data. Uncertainty in the estimates of stock biomass is high for the terminal years, confidence intervals for SSB are broadening to the direction of higher stock values.

The results of NSS herring stock assessment by means of TISVPA are given in Tables 3.7.2.2.1 - 3.7.2.2.3.

3.7.2.3 Data Exploration with Adapt

An assessment of Atlanto-scandian herring was done using an ADAPT type model. The model is written in AD-model builder and estimates the survivors in the beginning of the assessment year, survey catchabilities, standard deviation of each age group in each survey, geometric mean of recruitment and CV of recruitment. The model does assessment, recruitment estimate and prognosis in the same run.

From the estimated survivors the model is run backwards using Popes equation. The fishing mortality of the oldest age group is the mean of the two age groups before and the oldest age group can not be a plus group.

The model was run using catch at age from 1980-2005, ages 1 – 14, survey in the Norwegian sea 1996-2006 for ages 3 – 9, surveys from the Barents Sea for age 1 – 2 and survey on the spawning ground 1991 – 2006 (when it was conducted). One important difference between the model run and most other model runs is the use of so called resolution in the survey

residuals $\log\left(\frac{I_{y,a} + R}{\hat{I}_{y,a} + R}\right)$ – where the factor R should preferably be related to the otolith

sampling. In the work done here the extent otolith sampling was not available but the selected value of R was much larger than is often used but R is often a selected as a small number only to avoid log of zero. It turns out that the selection of R is important for this stock as the contrast in year class size is large.

In addition to the standard setting alternative settings were tested. The model results turned out to be rather sensitive to which age group was selected as the oldest group. It did not affect the state of the stock now but the spawning stock around 1990 was affected, probably due to problem with the 1983 year class that was still rather abundant at age 14.

3.7.3 Comparison of results of different assessments

The final results of the different assessment models are compared in Figure. 3.7.3.1. With the exception of the recruitment estimates of the most recent year classes, the results of all three models are almost identical and within the likely confidence range. All models indicate the SSB at the highest level around 2006 between 9.8 and 12 million tonnes. Historically the changes between SeaStar and ISVPA have become smaller. Both models use now the same data. The tagging data are not used in the SeaStar assessment this year while ISVPA has never used these data in previous years. Also the introduction of the cohort effect in the separable model (TISVPA) as a third parameter has changed the historical estimates of fishing mortalities around 1995 and are now more close to SeaStar. The Adapt assessment is new. There is little information in the catches and only few research vessels surveys to estimate the recruitment of the most recent year classes. The estimates between the different surveys differ and remain uncertain.

There are no strong arguments to reject any of the three assessments presented in this report using the different methods. The Working Group selected SeaStar as the preferred one, mainly

because this assessment was also accepted in previous years. However, it should be noted that this assessment appeared to be very sensitive to the decision to exclude tagging data.

3.7.4 Final Assessment

The SeaStar assessment was selected as the final assessment. The settings for the final run for the preferred model are described in section 3.7.2.1.

The results of the assessment are presented in Tables 3.7.4.1 (stock in numbers) and 3.7.4.2 (fishing mortality) and Figure 3.7.4.1. Table 3.7.4.3 is the summary table of the assessment. The retrospective plots are shown in Figure 3.7.2.1.5.

The assessment indicates that the fishing mortality in recent years has declined and is estimated around 0.10 in the period 2003-2005. This is below the target fishing mortality agreed in the management plan. A number of large year classes have appeared in recent years of which two year classes 2002 and 2004 will fully recruit in the spawning stock and in the fisheries in the coming years. The estimate of the 2004 year class is still uncertain but all available information indicate this is a strong year class. In general, it can be observed that the productivity in the stock in the last 20 years has increased by producing more frequently above average and strong year classes. As a result of these large year classes, in particular those born in 1998 and 1999, and the low fishing mortality, the SSB has increased in recent years and is estimated at 10.6 million tonnes in 2006. This is the highest SSB since 1957.

3.8 Recruitment estimates

Recruitment in this stock shows large annual variation and also periods with very low or abundant production. Presently the stock appears to be in a productive period. In the last 10 years a number of abundant year classes have occurred. Information from the surveys and catches indicate that the 2002 and 2004 year classes are (very strong) year classes.

In the period over which the assessment was carried out (1950-2004) recruitment varied between 0.077 and 302 billion 1-year-olds. The average recruitment at age 1 in this period was 38.4 (AM) or 10.4 (GM) 1-year-old.

2002 year class: Except for the 0-group survey, the indices of this year class are the highest or amongst the highest in all surveys. Comparable survey indices in previous years suggest that this year class is likely not higher than the 1992 year class. The estimate from the SeaStar assessment of this year class is 145 billion at age 1 and was accepted by the Working Group.

2003 year class: Only in the 0-group survey in Norwegian coastal waters indicate this year class as the most abundant in the time series. All other surveys indicate this year class as a moderate to average year class. The estimate in the assessment is 84 billion at age 1, which is well above average. Since the size of this year class seems to be reduced in progressive surveys and recent surveys indicate this year class to be about average, the estimate used by the Working Group in the prediction is the GM of the period 1986-2004 corresponding to 31 billion 1-year-olds.

2004 year class: This is an abundant year class, although the estimate of the actual size of this year class is still very uncertain. 0-group surveys estimate this year class as very abundant. In the Barents Sea it was also very abundant as 1- and 2-year-old but this was not the case in the Norwegian Sea. The estimate from the assessment is the highest in the time series but is mainly determined by the 0-group estimates. The estimate by the assessment was 241 million 1-year olds. This estimate was replaced by the Working Group with 128 million at age 1, similar as the large 1998 year class.

2005 year class: For this year class only a few observations are available from surveys at age 0 and 1. The indices of this year class are near or below the average of the time series. For this

year class and subsequent average GM recruitment of the period 1986-2004 of 31 billion 1-year old was assumed.

3.9 Forecast

3.9.1 Short term forecast

The input values for the forecast are given in Table 3.9.1.1. The exploitation patterns of the most recent 5 years in the assessment are shown in (Figure 3.9.1.1.) and are quite similar in the last three years. Therefore, the exploitation pattern in the forecast was taken as the average of the period 2003-2005. For the weight at age in the stock, the values for 2006 (obtained from the winter surveys) were taken and used in all years. For catch weight at age the average of the last 3 years (2003-2005) were taken. Except for the 2002 year class at age 4 in 2006 and at age 5 in 2007, the standard values for maturity at age have been taken in all years. The 2002 age class has matured earlier, and the values used for this year class in the forecast have been discussed elsewhere.

The Management Option Table with the results of the forecast is presented in Table 3.9.1.2. Assuming that a catch of 967 000 tonnes is taken in 2006, corresponding to the sum of the quota's set by the Coastal States for this year, it is expected that the SSB will remain near 10.5 million tonnes in 2007. The TAC in 2007, corresponding with the fishing mortality of 0.125 in the agreed Management Plan, is 1 280 000 tonnes. The expected remaining SSB in 2008 is 10.2 million tonnes.

3.10 Biological reference points

The precautionary reference points have not been reconsidered by the Working Group this year. The present values originate from an analyses carried out in 1998.

	ICES considers that:	ICES proposed that:
Precautionary Approach reference points	B_{lim} is 2.5 million t	B_{pa} be set at 5.0 million t
	F_{lim} is not considered relevant for this stock	F_{pa} be set at $F = 0.15$

Technical basis:

B_{lim} : MBAL	B_{pa} : $=B_{lim} * \exp(0.4*1.645)$ (ICES Study Group 1998)
F_{lim} : -	F_{pa} : ICES Study Group 1998

Target Reference Points

The Coastal States have agreed a target reference point defined at $F=0.125$. (Note that the average fishing mortality is calculated as a weighted mean over the age groups 5-14. (weighted over abundance))

3.11 Management considerations

3.12 Quality of the data and the assessment

Comparison with previous assessments

A comparison of the final assessment with previous assessments is given in Figure 3.12.1. Compared to last years assessment fishing mortality is estimated to be lower since 1995. The trends in fishing mortality in both assessments are similar. The differences are largest in the

years 2000-2002. The difference in 2004 is about 30%. Recruitment at age 1 in recent years is estimated to be somewhat higher in the recent assessment. The strong 2002 year class is estimated to be 150 billion 1-year-olds. This is about 40% higher than last year. The estimates for year classes 2003 and 2004 have been replaced by lower values in the catch forecast. The SSB has been estimated considerably higher by the recent assessment compared to last year. This is a consequence of the lower estimates of fishing mortality and higher estimates of recruitment. The main reason for the changes in the present assessment compared to last year are the exclusion of the tagging information and the last 4 years in the winter survey in the assessment.

Quality of the data

The results of the assessment appear to be not very sensitive to the choice of the assessment model (see section 0). With the exception of the estimation of recruitment of the most recent year classes the different models used gave almost the same results. The assessment appears to be more sensitive to the choice of the data used. Many sources of information are available which have contributed to the assessments in the past. The assessment carried out in 2006 appeared to be in particular sensitive to:

- use of tagging data;
- exclusion of recent years in winter survey;
- uncertainty in maturity parameters.

Exclusion of recent survey data from winter surveys and tagging data

Because of a change in the overwintering areas in recent years, the winter surveys in some recent years did not cover the whole stock. Therefore, it was decided to exclude these years from the final assessment. Compared to the SPALY SeaStar assessment this decision increased the SSB estimate for 2006 by 5 million tonnes. Exploration with different selections of tagging data in the assessment had also significant effect on the results of the assessment. Compared to the SPALY assessment the decision to remove all tagging information from the assessment reduced the SSB estimate for 2006 with about 2 million tonnes. The combined effect of removing the last 4 years of the winter surveys and the tagging data from the assessment gave about the same estimate as the SPALY run. (note that in these explorations a standard maturity was assumed for the 2002 year class).

Uncertainty in maturity parameters

In other herring stocks density dependent effects have been demonstrated in biological parameters such as growth and maturation. In North Sea herring a lower growth rate and a slower maturation was observed in the strong 2000 year class. For Norwegian spring spawning herring the situation seems to be different and more complicated. Juvenile herring of this stock occur as well in the Barents Sea, the Norwegian Sea and in Norwegian fjords. In the Norwegian Sea they grow faster and mature earlier. The weight at age in the stock and the proportion mature fish for the younger year classes therefore depends on the distribution of these year classes between the two areas in the first years of their lives. Apart from that, density dependent processes and changes in environmental conditions may contribute to a change in the biological parameters.

From the data available to the Working Group for the 2002 year class, it appeared that maturation is much earlier than assumed for previous year classes (see section 3.5.7). The impact of the value adopted by the Working Group for the 2002 year class on the SSB in 2006 is very large since this is a very strong year class. The value used by the Working Group resulted in a x million tonnes higher SSB compared with SSB estimate using the value for the same age group in other recent years. The SSB estimates of the present assessment are thus sensitive to the maturity ogive used by the Working Group. Since the observations on the

maturation of the 2002 year class are so different from the assumed "standard" values used for the other year classes and because several factors may be involved also affecting maturation for other year classes, it is necessary to evaluate all available information on maturity at age, at least in the last 10 years, before the next meeting of the Working Group.

3.13 Recommendations

- Given the large changes observed in the maturity at age data in recent years and the large effect it has on the estimation of the spawning stock, these data (at least for the last 10 years) should be reevaluated.
- Due to changes in the overwintering areas, the surveys in recent years directed to the overwintering mature stock have not covered the whole distribution area. It should be attempted to cover in future years the whole stock. Attempt to cover the whole mature stock in the winter surveys
- Problems have been reported with the coverage of the distribution area of the stock by surveys in the Barents Sea. In order to be used in the assessments, the surveys in the Barents Sea should cover the whole distribution area (Norwegian and Russian zone)

Table 3.5.1.1 Norwegian spring spawning herring. Output from SALLOC.

Summary of Sampling by Country

AREA : IIa

Country	Sampled Catch	Official Catch	No. of samples	No. measured	No. aged	SOP %
Denmark	0.00	23470.00	0	0	0	0.00
Faroe_Islands	36168.00	49185.00	3	203	202	99.97
Germany	0.00	15268.00	0	0	0	0.00
Iceland	115146.00	119134.00	19	1377	1240	100.03
NORWAY	580388.00	580388.00	210	23358	7601	99.99
Netherland	0.00	21517.00	0	0	0	0.00
Poland	0.00	561.00	0	0	0	0.00
RF	116659.00	116659.00	116	18420	3210	100.93
Sweden	0.00	680.00	0	0	0	0.00
Total IIa	848361.00	926862.00	348	43358	12253	100.12
Sum of Offical Catches :		926862.00				
Unallocated Catch :		0.00				
Discards :		0.00				
Working Group Catch :		926862.00				

AREA : IIb

Country	Sampled Catch	Official Catch	No. of samples	No. measured	No. aged	SOP %
Denmark	0.00	4898.00	0	0	0	0.00
Faroe_Islands	0.00	13946.00	0	0	0	0.00
Germany	0.00	2408.00	0	0	0	0.00
Iceland	0.00	25089.00	0	0	0	0.00
RF	15440.00	15440.00	13	3473	3	101.28
Total IIb	15440.00	61781.00	13	3473	3	101.28
Sum of Offical Catches :		61781.00				
Unallocated Catch :		0.00				
Discards :		0.00				
Working Group Catch :		61781.00				

AREA : IVa

Country	Sampled Catch	Official Catch	No. of samples	No. measured	No. aged	SOP %
NORWAY	416.00	416.00	25	2154	1652	100.24
Total IVa	416.00	416.00	25	2154	1652	100.24
Sum of Offical Catches :		416.00				
Unallocated Catch :		0.00				
Discards :		0.00				
Working Group Catch :		416.00				

AREA : Va

Country	Sampled Catch	Official Catch	No. of samples	No. measured	No. aged	SOP %
Faroe_Islands	0.00	1133.00	0	0	0	0.00
Iceland	1851.00	12244.00	71	175	92	99.98
Total Va	1851.00	13377.00	71	175	92	99.98
Sum of Offical Catches :		13377.00				
Unallocated Catch :		0.00				
Discards :		0.00				
Working Group Catch :		13377.00				

Table 3.5.1.1 (Cont'd)

AREA : Vb

Country	Sampled Catch	Official Catch	No. of samples	No. measured	No. aged	SOP %
Faroe_Islands	807.00	807.00	2	113	112	100.01
Total Vb	807.00	807.00	2	113	112	100.01

Sum of Official Catches :	807.00
Unallocated Catch :	0.00
Discards :	0.00
Working Group Catch :	807.00

PERIOD : 1

Country	Sampled Catch	Official Catch	No. of samples	No. measured	No. aged	SOP %
Denmark	0.00	2135.00	0	0	0	0.00
NORWAY	197889.00	197889.00	64	5640	3115	100.05
RF	31730.00	31730.00	26	3282	798	100.00
Period Total	229619.00	231754.00	90	8922	3913	100.05

Sum of Official Catches :	231754.00
Unallocated Catch :	0.00
Discards :	0.00
Working Group Catch :	231754.00

PERIOD : 2

Country	Sampled Catch	Official Catch	No. of samples	No. measured	No. aged	SOP %
Denmark	0.00	11173.00	0	0	0	0.00
Faroe_Islands	0.00	17441.00	0	0	0	0.00
Germany	0.00	8329.00	0	0	0	0.00
Iceland	32003.00	55261.00	10	686	655	99.99
NORWAY	4859.00	4859.00	64	6525	3115	100.03
Netherlands	0.00	1610.00	0	0	0	0.00
RF	3613.00	3613.00	23	3877	680	100.00
Sweden	0.00	680.00	0	0	0	0.00
Period Total	40475.00	102966.00	97	11088	4450	100.06

Sum of Official Catches :	102966.00
Unallocated Catch :	0.00
Discards :	0.00
Working Group Catch :	102966.00

PERIOD : 3

Country	Sampled Catch	Official Catch	No. of samples	No. measured	No. aged	SOP %
Denmark	0.00	15060.00	0	0	0	0.00
Faroe_Islands	36975.00	46117.00	5	316	314	99.97
Germany	0.00	9347.00	0	0	0	0.00
Iceland	83143.00	95367.00	9	691	585	100.05
NORWAY	19843.00	19843.00	35	4398	1574	99.96
Netherlands	0.00	14105.00	0	0	0	0.00
RF	89013.00	89013.00	75	13648	1733	101.33
Period Total	228974.00	288852.00	124	19053	4206	100.52

Sum of Official Catches :	288852.00
Unallocated Catch :	0.00
Discards :	0.00
Working Group Catch :	288852.00

Table 3.5.1.1 (Cont'd)

PERIOD : 4

Country	Sampled Catch	Official Catch	No. of samples	No. measured	No. aged	SOP %
Faroe_Islands	0.00	1513.00	0	0	0	0.00
Iceland	1851.00	5839.00	71	175	92	99.98
NORWAY	358213.00	358213.00	72	8949	1449	99.95
Netherlands	0.00	5802.00	0	0	0	0.00
Poland	0.00	561.00	0	0	0	0.00
RF	7743.00	7743.00	5	1086	2	101.32
Period Total	367807.00	379671.00	148	10210	1543	99.98
Sum of Official Catches :		379671.00				
Unallocated Catch :		0.00				
Discards :		0.00				
Working Group Catch :		379671.00				

Total over all Areas and Periods

Country	Sampled Catch	Official Catch	No. of samples	No. measured	No. aged	SOP %
Denmark	0.00	28368.00	0	0	0	0.00
Faroe_Islands	36975.00	65071.00	5	316	314	99.97
Germany	0.00	17676.00	0	0	0	0.00
Iceland	116997.00	156467.00	90	1552	1332	100.03
NORWAY	580804.00	580804.00	235	25512	9253	99.99
Netherlands	0.00	21517.00	0	0	0	0.00
Poland	0.00	561.00	0	0	0	0.00
RF	132099.00	132099.00	129	21893	3213	100.97
Sweden	0.00	680.00	0	0	0	0.00
Total for Stock	866875.00	1003243.00	459	49273	14112	100.14
Sum of Official Catches :		1003243.00				
Unallocated Catch :		0.00				
Discards :		0.00				
Working Group Catch :		1003243.00				

DETAILS OF DATA FILLING-IN

```

Filling-in for record : ( 13) Denmark                1 IIa
Unweighted Mean of :
>> ( 1) NORWAY                1 IIa
>> ( 32) RF                    1 IIa

Filling-in for record : ( 6) Faroe_Islands           2 IIa
Unweighted Mean of :
>> ( 18) Iceland              2 IIa
>> ( 33) RF                    2 IIa

Filling-in for record : ( 14) Denmark                2 IIa
Unweighted Mean of :
>> ( 2) NORWAY                2 IIa
>> ( 33) RF                    2 IIa

Filling-in for record : ( 25) Germany                2 IIa
Unweighted Mean of :
>> ( 2) NORWAY                2 IIa
>> ( 33) RF                    2 IIa

Filling-in for record : ( 29) Netherlands            2 IIa
Unweighted Mean of :
>> ( 2) NORWAY                2 IIa
>> ( 33) RF                    2 IIa

Filling-in for record : ( 40) Sweden                 2 IIa
Unweighted Mean of :
>> ( 2) NORWAY                2 IIa
>> ( 33) RF                    2 IIa

Filling-in for record : ( 9) Faroe_Islands           2 IIb
Using Only
>> ( 36) RF                    2 IIb

Filling-in for record : ( 16) Denmark                2 IIb

```

Table 3.5.1.1 (Cont'd)

Using Only			
>> (36) RF		2 I Ib	
Filling-in for record : (21)	Iceland		2 I Ib
Using Only			
>> (36) RF		2 I Ib	
Filling-in for record : (27)	Germany		2 I Ib
Using Only			
>> (36) RF		2 I Ib	
Filling-in for record : (12)	Faroe_Islands		2 Va
Using Only			
>> (18) Iceland		2 I Ia	
Filling-in for record : (23)	Iceland		2 Va
Using Only			
>> (18) Iceland		2 I Ia	
Filling-in for record : (15)	Denmark		3 I Ia
Using Only			
>> (34) RF		3 I Ia	
Filling-in for record : (26)	Germany		3 I Ia
Using Only			
>> (34) RF		3 I Ia	
Filling-in for record : (30)	Netherland		3 I Ia
Using Only			
>> (34) RF		3 I Ia	
Filling-in for record : (10)	Faroe_Islands		3 I Ib
Using Only			
>> (37) RF		3 I Ib	
Filling-in for record : (17)	Denmark		3 I Ib
Using Only			
>> (37) RF		3 I Ib	
Filling-in for record : (22)	Iceland		3 I Ib
Using Only			
>> (37) RF		3 I Ib	
Filling-in for record : (28)	Germany		3 I Ib
Using Only			
>> (37) RF		3 I Ib	
Filling-in for record : (8)	Faroe_Islands		4 I Ia
Using Only			
>> (35) RF		4 I Ia	
Filling-in for record : (20)	Iceland		4 I Ia
Using Only			
>> (35) RF		4 I Ia	
Filling-in for record : (31)	Netherland		4 I Ia
Using Only			
>> (35) RF		4 I Ia	
Filling-in for record : (39)	Poland		4 I Ia
Using Only			
>> (35) RF		4 I Ia	

Table 3.5.1.1 (Cont'd)

Catch Numbers at Age by Area

For Periods 1 to 4

Ages	IIa	IIB	IVa	Va	Vb	Total
0	0.00	0.00	0.00	0.00	0.00	0.00
1	442.00	0.00	0.00	0.00	0.00	442.00
2	17613.48	2364.95	1.00	24.85	0.00	20004.28
3	410336.00	21804.33	2.00	2883.95	0.00	435026.28
4	81652.91	12139.85	18.00	681.36	0.00	94492.13
5	146349.81	14236.40	66.00	2070.30	104.00	162826.50
6	582149.38	40728.03	489.00	9608.74	594.00	633569.13
7	869890.81	59163.94	656.00	9682.96	755.00	940148.69
8	111745.58	6148.81	34.00	1938.45	470.00	120336.84
9	114217.48	8660.38	43.00	1274.03	132.00	124326.90
10	29731.15	5088.80	5.00	479.29	44.00	35348.25
11	56113.12	8182.54	10.00	1746.26	40.00	66091.92
12	128875.38	13428.37	34.00	1802.40	131.00	144271.14
13	330144.59	12220.30	107.00	8981.64	47.00	351500.50
14	124960.38	2397.77	51.00	1813.42	66.00	129288.55
15	14176.77	639.94	0.00	1201.46	0.00	16018.18

Mean Weight at Age by Area (Kg)

For Periods 1 to 4

Ages	IIa	IIB	IVa	Va	Vb	Total
0	0.0000	0.0000	0.0000	0.0000	0.0000	0.0000
1	0.0920	0.0000	0.0000	0.0000	0.0000	0.0920
2	0.1053	0.0854	0.2070	0.1430	0.0000	0.1030
3	0.1801	0.1760	0.1930	0.1791	0.0000	0.1799
4	0.2345	0.2318	0.2310	0.2289	0.0000	0.2341
5	0.2667	0.2634	0.2290	0.2511	0.3150	0.2663
6	0.2906	0.2972	0.2480	0.2687	0.3220	0.2907
7	0.3160	0.3105	0.2700	0.2825	0.3320	0.3153
8	0.3463	0.3339	0.3130	0.3168	0.3370	0.3451
9	0.3680	0.3573	0.3370	0.3235	0.3580	0.3668
10	0.3901	0.3873	0.3510	0.3448	0.3840	0.3891
11	0.3733	0.3681	0.3310	0.3578	0.3560	0.3722
12	0.3840	0.3768	0.3400	0.3547	0.3890	0.3830
13	0.3986	0.3949	0.3600	0.3603	0.3860	0.3975
14	0.4023	0.4072	0.3620	0.3768	0.4020	0.4020
15	0.4138	0.4155	0.0000	0.4062	0.0000	0.4133

Mean Length at Age by Area (cm)

For Periods 1 to 4

Ages	IIa	IIB	IVa	Va	Vb	Total
0	0.0000	0.0000	0.0000	0.0000	0.0000	0.0000
1	21.0000	0.0000	0.0000	0.0000	0.0000	21.0000
2	23.6426	21.3122	30.0000	24.5000	0.0000	23.3685
3	27.7853	27.4421	29.8000	26.9021	0.0000	27.7622
4	30.0863	31.0659	29.7000	29.6473	0.0000	30.2089
5	31.2833	31.8341	31.0000	30.9324	31.8000	31.3272
6	32.1886	32.8461	31.6000	31.6530	32.2000	32.2223
7	32.9736	33.5963	32.4000	32.2642	32.7000	33.0049
8	33.9522	34.5587	33.3000	33.7351	33.0000	33.9758
9	34.7046	35.7000	34.6000	34.0132	34.1000	34.7662
10	35.6861	36.6000	34.6000	34.7643	35.5000	35.8048
11	35.5222	36.2000	35.0000	35.1990	34.0000	35.5965
12	35.6334	36.6465	35.2000	35.0975	35.7000	35.7210
13	35.6648	37.1391	35.4000	35.3659	35.6000	35.7084
14	36.0249	37.6533	35.5000	35.7597	36.4000	36.0513
15	37.0013	38.9763	0.0000	36.6315	0.0000	37.0525

Table 3.5.1.1 (Cont'd)

Catch Numbers at Age by Area

For Period 1

Ages	IIa	IIb	IVa	Va	Vb	Total
0	0.00	0.00	0.00	0.00	0.00	0.00
1	0.00	0.00	0.00	0.00	0.00	0.00
2	1118.00	0.00	0.00	0.00	0.00	1118.00
3	9778.26	0.00	0.00	0.00	0.00	9778.26
4	9895.82	0.00	0.00	0.00	0.00	9895.82
5	29565.87	0.00	0.00	0.00	0.00	29565.87
6	171113.39	0.00	0.00	0.00	0.00	171113.39
7	283688.81	0.00	0.00	0.00	0.00	283688.81
8	31729.95	0.00	0.00	0.00	0.00	31729.95
9	32728.84	0.00	0.00	0.00	0.00	32728.84
10	1825.26	0.00	0.00	0.00	0.00	1825.26
11	17040.70	0.00	0.00	0.00	0.00	17040.70
12	37451.71	0.00	0.00	0.00	0.00	37451.71
13	90445.04	0.00	0.00	0.00	0.00	90445.04
14	54882.07	0.00	0.00	0.00	0.00	54882.07
15	4180.79	0.00	0.00	0.00	0.00	4180.79

Mean Weight at Age by Area (Kg)

For Period 1

Ages	IIa	IIb	IVa	Va	Vb	Total
0	0.0000	0.0000	0.0000	0.0000	0.0000	0.0000
1	0.0000	0.0000	0.0000	0.0000	0.0000	0.0000
2	0.0890	0.0000	0.0000	0.0000	0.0000	0.0890
3	0.1328	0.0000	0.0000	0.0000	0.0000	0.1328
4	0.1940	0.0000	0.0000	0.0000	0.0000	0.1940
5	0.2257	0.0000	0.0000	0.0000	0.0000	0.2257
6	0.2536	0.0000	0.0000	0.0000	0.0000	0.2536
7	0.2806	0.0000	0.0000	0.0000	0.0000	0.2806
8	0.3215	0.0000	0.0000	0.0000	0.0000	0.3215
9	0.3417	0.0000	0.0000	0.0000	0.0000	0.3417
10	0.3490	0.0000	0.0000	0.0000	0.0000	0.3490
11	0.3653	0.0000	0.0000	0.0000	0.0000	0.3653
12	0.3595	0.0000	0.0000	0.0000	0.0000	0.3595
13	0.3785	0.0000	0.0000	0.0000	0.0000	0.3785
14	0.3850	0.0000	0.0000	0.0000	0.0000	0.3850
15	0.4225	0.0000	0.0000	0.0000	0.0000	0.4225

Mean Length at Age by Area (cm)

For Period 1

Ages	IIa	IIb	IVa	Va	Vb	Total
0	0.0000	0.0000	0.0000	0.0000	0.0000	0.0000
1	0.0000	0.0000	0.0000	0.0000	0.0000	0.0000
2	22.5000	0.0000	0.0000	0.0000	0.0000	22.5000
3	26.1659	0.0000	0.0000	0.0000	0.0000	26.1659
4	29.0383	0.0000	0.0000	0.0000	0.0000	29.0383
5	30.5818	0.0000	0.0000	0.0000	0.0000	30.5818
6	31.6617	0.0000	0.0000	0.0000	0.0000	31.6617
7	32.3752	0.0000	0.0000	0.0000	0.0000	32.3752
8	33.5715	0.0000	0.0000	0.0000	0.0000	33.5715
9	34.2708	0.0000	0.0000	0.0000	0.0000	34.2708
10	34.7265	0.0000	0.0000	0.0000	0.0000	34.7265
11	35.3046	0.0000	0.0000	0.0000	0.0000	35.3046
12	35.2515	0.0000	0.0000	0.0000	0.0000	35.2515
13	35.4178	0.0000	0.0000	0.0000	0.0000	35.4178
14	35.7700	0.0000	0.0000	0.0000	0.0000	35.7700
15	37.4482	0.0000	0.0000	0.0000	0.0000	37.4482

Table 3.5.1.1 (Cont'd)

Catch Numbers at Age by Area

For Period 2

Ages	IIa	IIb	IVa	Va	Vb	Total
0	0.00	0.00	0.00	0.00	0.00	0.00
1	0.00	0.00	0.00	0.00	0.00	0.00
2	945.80	817.72	1.00	24.85	0.00	1789.37
3	14383.72	4992.38	2.00	2881.95	0.00	22260.05
4	7271.96	5035.42	18.00	667.36	0.00	12992.74
5	12655.76	4691.11	66.00	2009.30	0.00	19422.18
6	50817.90	10974.62	489.00	9145.74	0.00	71427.27
7	65346.13	20442.92	656.00	8991.96	0.00	95437.01
8	9759.66	2539.23	34.00	1711.45	0.00	14044.33
9	8611.84	3184.79	43.00	1106.03	0.00	12945.67
10	3232.53	2022.77	5.00	402.29	0.00	5662.60
11	8697.99	3572.13	10.00	1458.26	0.00	13738.39
12	12487.63	6240.47	34.00	1509.40	0.00	20271.51
13	34464.35	4777.19	107.00	7501.64	0.00	46850.18
14	9366.31	1118.98	51.00	1451.42	0.00	11987.71
15	3396.71	301.26	0.00	892.46	0.00	4590.43

Mean Weight at Age by Area (Kg)

For Period 2

Ages	IIa	IIb	IVa	Va	Vb	Total
0	0.0000	0.0000	0.0000	0.0000	0.0000	0.0000
1	0.0000	0.0000	0.0000	0.0000	0.0000	0.0000
2	0.0915	0.0730	0.2070	0.1430	0.0000	0.0838
3	0.1655	0.1390	0.1930	0.1790	0.0000	0.1613
4	0.2207	0.2230	0.2310	0.2270	0.0000	0.2219
5	0.2443	0.2460	0.2290	0.2490	0.0000	0.2451
6	0.2658	0.2760	0.2480	0.2650	0.0000	0.2672
7	0.2797	0.2810	0.2700	0.2770	0.0000	0.2796
8	0.3142	0.3210	0.3130	0.3080	0.0000	0.3147
9	0.3330	0.3510	0.3370	0.3140	0.0000	0.3358
10	0.3491	0.3740	0.3510	0.3300	0.0000	0.3567
11	0.3509	0.3630	0.3310	0.3410	0.0000	0.3530
12	0.3526	0.3720	0.3400	0.3380	0.0000	0.3575
13	0.3565	0.3870	0.3600	0.3440	0.0000	0.3576
14	0.3739	0.4040	0.3620	0.3530	0.0000	0.3741
15	0.3791	0.4060	0.0000	0.3720	0.0000	0.3795

Mean Length at Age by Area (cm)

For Period 2

Ages	IIa	IIb	IVa	Va	Vb	Total
0	0.0000	0.0000	0.0000	0.0000	0.0000	0.0000
1	0.0000	0.0000	0.0000	0.0000	0.0000	0.0000
2	21.7273	20.2000	30.0000	24.5000	0.0000	21.0725
3	26.5854	25.9000	29.8000	26.9000	0.0000	26.4727
4	30.1756	31.3000	29.7000	29.6000	0.0000	30.5812
5	31.0547	31.7000	31.0000	30.9000	0.0000	31.1943
6	31.8561	32.7000	31.6000	31.6000	0.0000	31.9512
7	32.5991	33.4000	32.4000	32.2000	0.0000	32.7317
8	33.8414	34.5000	33.3000	33.7000	0.0000	33.9419
9	34.6042	35.7000	34.6000	34.0000	0.0000	34.8221
10	35.3720	36.6000	34.6000	34.7000	0.0000	35.7622
11	35.3705	36.2000	35.0000	35.1000	0.0000	35.5572
12	35.5680	36.7000	35.2000	35.0000	0.0000	35.8736
13	35.6477	37.2000	35.4000	35.3000	0.0000	35.7497
14	36.1235	37.6000	35.5000	35.6000	0.0000	36.1953
15	36.7206	38.5000	0.0000	36.4000	0.0000	36.7750

Table 3.5.1.1 (Cont'd)

Catch Numbers at Age by Area

For Period 3

Ages	IIa	IIb	IVa	Va	Vb	Total
0	0.00	0.00	0.00	0.00	0.00	0.00
1	442.00	0.00	0.00	0.00	0.00	442.00
2	4869.85	1521.23	0.00	0.00	0.00	6391.07
3	142071.13	16525.95	0.00	0.00	0.00	158597.08
4	36251.24	6983.44	0.00	0.00	0.00	43234.68
5	54785.32	9383.28	0.00	0.00	104.00	64272.60
6	187372.67	29247.41	0.00	0.00	594.00	217214.08
7	211457.78	38062.01	0.00	0.00	755.00	250274.78
8	31435.02	3548.59	0.00	0.00	470.00	35453.61
9	26116.34	5382.59	0.00	0.00	132.00	31630.94
10	12235.43	3014.02	0.00	0.00	44.00	15293.45
11	19301.33	4532.41	0.00	0.00	40.00	23873.74
12	29799.54	7065.90	0.00	0.00	131.00	36996.44
13	51906.24	7316.12	0.00	0.00	47.00	59269.35
14	13787.67	1256.79	0.00	0.00	66.00	15110.46
15	2122.55	332.68	0.00	0.00	0.00	2455.23

Mean Weight at Age by Area (Kg)

For Period 3

Ages	IIa	IIb	IVa	Va	Vb	Total
0	0.0000	0.0000	0.0000	0.0000	0.0000	0.0000
1	0.0920	0.0000	0.0000	0.0000	0.0000	0.0920
2	0.0999	0.0920	0.0000	0.0000	0.0000	0.0981
3	0.1913	0.1870	0.0000	0.0000	0.0000	0.1908
4	0.2360	0.2380	0.0000	0.0000	0.0000	0.2363
5	0.2729	0.2720	0.0000	0.0000	0.3150	0.2728
6	0.3050	0.3050	0.0000	0.0000	0.3220	0.3050
7	0.3242	0.3260	0.0000	0.0000	0.3320	0.3245
8	0.3463	0.3430	0.0000	0.0000	0.3370	0.3459
9	0.3675	0.3610	0.0000	0.0000	0.3580	0.3663
10	0.3930	0.3960	0.0000	0.0000	0.3840	0.3935
11	0.3810	0.3720	0.0000	0.0000	0.3560	0.3793
12	0.3899	0.3810	0.0000	0.0000	0.3890	0.3882
13	0.4055	0.4000	0.0000	0.0000	0.3860	0.4048
14	0.4234	0.4100	0.0000	0.0000	0.4020	0.4222
15	0.4185	0.4240	0.0000	0.0000	0.0000	0.4192

Mean Length at Age by Area (cm)

For Period 3

Ages	IIa	IIb	IVa	Va	Vb	Total
0	0.0000	0.0000	0.0000	0.0000	0.0000	0.0000
1	21.0000	0.0000	0.0000	0.0000	0.0000	21.0000
2	22.3655	21.9000	0.0000	0.0000	0.0000	22.2547
3	27.3219	27.9000	0.0000	0.0000	0.0000	27.3821
4	29.9274	30.9000	0.0000	0.0000	0.0000	30.0845
5	31.1592	31.9000	0.0000	0.0000	31.8000	31.2684
6	32.1886	32.9000	0.0000	0.0000	32.2000	32.2845
7	32.9674	33.7000	0.0000	0.0000	32.7000	33.0780
8	33.5708	34.6000	0.0000	0.0000	33.0000	33.6663
9	35.0241	35.7000	0.0000	0.0000	34.1000	35.1353
10	35.9750	36.6000	0.0000	0.0000	35.5000	36.0968
11	35.6722	36.2000	0.0000	0.0000	34.0000	35.7696
12	36.0853	36.6000	0.0000	0.0000	35.7000	36.1822
13	35.9108	37.1000	0.0000	0.0000	35.6000	36.0574
14	36.3126	37.7000	0.0000	0.0000	36.4000	36.4284
15	37.0077	39.4000	0.0000	0.0000	0.0000	37.3318

Table 3.5.1.1 (Cont'd)

Catch Numbers at Age by Area

For Period 4

Ages	IIa	IIb	IVa	Va	Vb	Total
0	0.00	0.00	0.00	0.00	0.00	0.00
1	0.00	0.00	0.00	0.00	0.00	0.00
2	10679.84	26.00	0.00	0.00	0.00	10705.84
3	244102.92	286.00	0.00	2.00	0.00	244390.92
4	28233.89	121.00	0.00	14.00	0.00	28368.89
5	49342.85	162.00	0.00	61.00	0.00	49565.85
6	172845.36	506.00	0.00	463.00	0.00	173814.36
7	309398.13	659.00	0.00	691.00	0.00	310748.13
8	38820.95	61.00	0.00	227.00	0.00	39108.95
9	46760.46	93.00	0.00	168.00	0.00	47021.46
10	12437.93	52.00	0.00	77.00	0.00	12566.93
11	11073.08	78.00	0.00	288.00	0.00	11439.08
12	49136.48	122.00	0.00	293.00	0.00	49551.48
13	153328.94	127.00	0.00	1480.00	0.00	154935.94
14	46924.33	22.00	0.00	362.00	0.00	47308.33
15	4476.73	6.00	0.00	309.00	0.00	4791.73

Mean Weight at Age by Area (Kg)

For Period 4

Ages	IIa	IIb	IVa	Va	Vb	Total
0	0.0000	0.0000	0.0000	0.0000	0.0000	0.0000
1	0.0000	0.0000	0.0000	0.0000	0.0000	0.0000
2	0.1107	0.0920	0.0000	0.0000	0.0000	0.1106
3	0.1763	0.1870	0.0000	0.2630	0.0000	0.1764
4	0.2504	0.2380	0.0000	0.3180	0.0000	0.2504
5	0.2902	0.2720	0.0000	0.3190	0.0000	0.2902
6	0.3188	0.3050	0.0000	0.3410	0.0000	0.3188
7	0.3505	0.3260	0.0000	0.3540	0.0000	0.3505
8	0.3746	0.3430	0.0000	0.3830	0.0000	0.3746
9	0.3932	0.3610	0.0000	0.3860	0.0000	0.3931
10	0.4040	0.3960	0.0000	0.4220	0.0000	0.4041
11	0.3898	0.3720	0.0000	0.4430	0.0000	0.3910
12	0.4071	0.3810	0.0000	0.4410	0.0000	0.4073
13	0.4176	0.4000	0.0000	0.4430	0.0000	0.4178
14	0.4219	0.4100	0.0000	0.4720	0.0000	0.4222
15	0.4298	0.4240	0.0000	0.5050	0.0000	0.4346

Mean Length at Age by Area (cm)

For Period 4

Ages	IIa	IIb	IVa	Va	Vb	Total
0	0.0000	0.0000	0.0000	0.0000	0.0000	0.0000
1	0.0000	0.0000	0.0000	0.0000	0.0000	0.0000
2	24.5142	21.9000	0.0000	0.0000	0.0000	24.5078
3	28.1905	27.9000	0.0000	30.0000	0.0000	28.1902
4	30.6346	30.9000	0.0000	31.9000	0.0000	30.6364
5	31.9000	31.9000	0.0000	32.0000	0.0000	31.9001
6	32.8079	32.9000	0.0000	32.7000	0.0000	32.8079
7	33.6057	33.7000	0.0000	33.1000	0.0000	33.6048
8	34.6000	34.6000	0.0000	34.0000	0.0000	34.5965
9	34.8483	35.7000	0.0000	34.1000	0.0000	34.8473
10	35.6244	36.6000	0.0000	35.1000	0.0000	35.6253
11	35.7145	36.2000	0.0000	35.7000	0.0000	35.7174
12	35.6670	36.6000	0.0000	35.6000	0.0000	35.6689
13	35.7311	37.1000	0.0000	35.7000	0.0000	35.7320
14	36.2187	37.7000	0.0000	36.4000	0.0000	36.2208
15	36.7939	39.4000	0.0000	37.3000	0.0000	36.8298

Table 3.5.1.2. Norwegian Spring Spawning Herring; summary of sampling data of the catches in 2006. The data of the Netherlands and Denmark could not be used because the supplied age range was smaller than the one used by the Working Group.

Total over all Areas and Periods

Country	Sampled Catch	Official Catch	No. of samples	No. measured	No. aged	SOP %
Sweden	0	680	0	0	0	0
Russia	132099	132099	131	21891	4109	100.97
Poland	0	561	0	0	0	0
Norway	580804	580804	235	25512	9253	99.87
Netherlands	21517	21517	19	475	475	100.0
Iceland	127390	156467	100	2111	1342	99.83
Germany	0	17676	0	0	0	0
Faroes	36168	65071	3	203	202	99.97
Denmark	28368	28368	10	1124	228	100
Total for Stock	904829	1003243	469	49717	14906	96.9

Table 3.5.2.1 Total catch of Norwegian spring-spawning herring (tons) since 1972. Data provided by Working Group members.

YEAR	NORWAY	USSR/ RUSSIA	DENMARK	FAROES	ICELAND	IRELAND	NETHERLANDS	GREENLAND	UK (SCOTLAND)	GERMANY	FRANCE	POLAND	SWEDEN	TOTAL
1972	13,161	-	-	-	-	-	-	-	-	-	-	-	-	13,161
1973	7,017	-	-	-	-	-	-	-	-	-	-	-	-	7,017
1974	7,619	-	-	-	-	-	-	-	-	-	-	-	-	7,619
1975	13,713	-	-	-	-	-	-	-	-	-	-	-	-	13,713
1976	10,436	-	-	-	-	-	-	-	-	-	-	-	-	10,436
1977	22,706	-	-	-	-	-	-	-	-	-	-	-	-	22,706
1978	19,824	-	-	-	-	-	-	-	-	-	-	-	-	19,824
1979	12,864	-	-	-	-	-	-	-	-	-	-	-	-	12,864
1980	18,577	-	-	-	-	-	-	-	-	-	-	-	-	18,577
1981	13,736	-	-	-	-	-	-	-	-	-	-	-	-	13,736
1982	16,655	-	-	-	-	-	-	-	-	-	-	-	-	16,655
1983	23,054	-	-	-	-	-	-	-	-	-	-	-	-	23,054
1984	53,532	-	-	-	-	-	-	-	-	-	-	-	-	53,532
1985	167,272	2,600	-	-	-	-	-	-	-	-	-	-	-	169,872
1986	199,256	26,000	-	-	-	-	-	-	-	-	-	-	-	225,256
1987	108,417	18,889	-	-	-	-	-	-	-	-	-	-	-	127,306
1988	115,076	20,225	-	-	-	-	-	-	-	-	-	-	-	135,301
1989	88,707	15,123	-	-	-	-	-	-	-	-	-	-	-	103,830
1990	74,604	11,807	-	-	-	-	-	-	-	-	-	-	-	86,411
1991	73,683	11,000	-	-	-	-	-	-	-	-	-	-	-	84,683
1992	91,111	13,337	-	-	-	-	-	-	-	-	-	-	-	104,448
1993	199,771	32,645	-	-	-	-	-	-	-	-	-	-	-	232,457
1994	380,771	74,400	-	2,911	21,146	-	-	-	-	-	-	-	-	479,228
1995	529,838	101,987	30,577	57,084	174,109	-	7,969	2,500	881	556	-	-	-	905,501
1996	699,161	119,290	60,681	52,788	164,957	19,541	19,664	-	46,131	11,978	-	-	22,424	1,220,283
1997	860,963	168,900	44,292	59,987	220,154	11,179	8,694	-	25,149	6,190	1,500	-	19,499	1,426,507
1998	743,925	124,049	35,519	68,136	197,789	2,437	12,827	-	15,971	7,003	605	-	14,863	1,223,131
1999	740,640	157,328	37,010	55,527	203,381	2,412	5,871	-	19,207	-	-	-	14,057	1,235,433
2000	713,500	163,261	34,968	68,625	186,035	8,939	-	-	14,096	3,298	-	-	14,749	1,207,201
2001	495,036	109,054	24,038	34,170	77,693	6,070	6,439	-	12,230	1,588	-	-	9,818	766,136
2002	487,233	113,763	18,998	32,302	127,197	1,699	9,392	-	3,482	3,017	-	1,226	9,486	807,795
2003*	477,573	122,846	14,144	27,943	117,910	1,400	8,678	-	9,214	3,371	-	-	6,431	789,510
2004	477,076	115,876	23,111	42,771	102,787	11	17,369	-	1,869	4,810	400	-	7,986	794,066
2005**	580,804	132,099	28,368	65,071	156,467	-	21,517	-	-	17,676	0	561	680	1,003,243

*In 2003 the Norwegian catches were raised of 39433 to account for changes in percentages of water content.

**Preliminary, as provided by Working Group members.

Table 3.5.4.1. Norwegian spring spawning herring. Catch in numbers (billions).

YEAR	AGE																
	0	1	2	3	4	5	6	7	8	9	10	11	12	13	14	15	16
1950	5.113	2	0.6	0.276	0.185	0.186	0.547	0.629	0.08	0.089	0.11	0.087	0.195	0.368	0.066	0.107	0.237
1951	1.636	7.608	0.4	0.007	0.384	0.172	0.164	0.516	0.602	0.077	0.083	0.103	0.108	0.254	0.348	0.047	0.305
1952	13.72	9.15	1.233	0.039	0.061	0.602	0.136	0.205	0.38	0.378	0.079	0.086	0.108	0.107	0.187	0.256	0.308
1953	5.697	5.055	0.581	0.74	0.047	0.101	0.356	0.082	0.111	0.314	0.395	0.062	0.091	0.094	0.099	0.216	0.515
1954	10.68	7.071	0.855	0.266	1.436	0.143	0.236	0.49	0.128	0.2	0.44	0.461	0.088	0.101	0.133	0.127	0.676
1955	5.176	2.871	0.51	0.093	0.276	2.045	0.114	0.19	0.275	0.085	0.193	0.296	0.203	0.059	0.085	0.104	0.477
1956	5.364	2.024	0.627	0.117	0.252	0.314	2.555	0.11	0.204	0.264	0.131	0.198	0.273	0.163	0.063	0.089	0.476
1957	5.002	3.291	0.22	0.023	0.373	0.154	0.229	1.985	0.072	0.127	0.183	0.088	0.121	0.149	0.132	0.034	0.248
1958	9.667	2.798	0.666	0.018	0.018	0.111	0.089	0.194	0.973	0.071	0.123	0.201	0.099	0.077	0.071	0.069	0.186
1959	17.9	0.199	0.326	0.015	0.027	0.026	0.147	0.115	0.241	1.104	0.089	0.124	0.198	0.089	0.077	0.085	0.151
1960	12.88	13.58	0.393	0.122	0.018	0.028	0.024	0.096	0.073	0.204	1.163	0.085	0.13	0.154	0.057	0.047	0.122
1961	6.208	16.08	2.885	0.031	0.008	0.004	0.015	0.019	0.062	0.049	0.136	0.728	0.05	0.045	0.063	0.022	0.038
1962	3.693	4.081	1.041	1.844	0.008	0.003	0.007	0.02	0.012	0.059	0.053	0.117	0.814	0.044	0.055	0.066	0.087
1963	4.807	2.119	2.045	0.76	0.836	0.005	0.002	0.004	0.018	0.009	0.108	0.093	0.174	0.924	0.08	0.06	0.125
1964	3.613	2.728	0.22	0.115	0.399	2.046	0.014	0.002	0.003	0.025	0.029	0.096	0.082	0.153	0.773	0.046	0.291
1965	2.303	3.781	2.854	0.09	0.256	0.571	2.2	0.02	0.015	0.007	0.019	0.04	0.101	0.108	0.139	0.704	0.179
1966	3.927	0.663	1.678	2.049	0.027	0.467	1.306	2.885	0.038	0.014	0.017	0.026	0.011	0.069	0.072	0.097	0.46
1967	0.427	9.877	0.07	1.392	3.254	0.027	0.421	1.132	1.721	0.009	0.006	0.004	0.008	0.009	0.018	0.014	0.09
1968	1.784	0.437	0.388	0.099	1.881	1.387	0.014	0.094	0.134	0.345	0.002	0.001	0	0.003	0.003	0.002	0.015
1969	0.561	0.507	0.142	0.188	0	0.009	0.005	0	0.012	0.034	0.036	0	0	0	0	0	0.002
1970	0.119	0.529	0.033	0.006	0.019	0	0.003	0.003	0.001	0.013	0.026	0.028	0	0	0	0	0.002
1971	0.031	0.043	0.085	0.002	0.001	0.001	0	0.001	0.001	0	0.004	0.007	0.005	0	0	0	0
1972	0.347	0.041	0.02	0.035	0.003	0.004	0.002	0	0.001	0	0	0	0	0	0	0	0
1973	0.029	0.004	0.002	0.002	0.025	0	0.002	0	0	0	0	0	0	0	0	0	0
1974	0.066	0.008	0.004	0	0	0.025	0	0	0	0	0	0	0	0	0	0	0
1975	0.031	0.004	0.002	0.003	0	0	0.031	0	0	0	0	0	0	0	0	0	0
1976	0.02	0.002	0.001	0.023	0.005	0	0	0.013	0	0	0	0	0	0	0	0	0
1977	0.043	0.006	0.003	0.022	0.024	0	0	0	0.011	0	0	0	0	0	0	0	0
1978	0.02	0.002	0.001	0.003	0.012	0.02	0	0	0	0.005	0	0	0	0	0	0	0
1979	0.033	0.004	0.002	0.006	0.002	0.007	0.011	0	0	0	0.003	0	0	0	0	0	0
1980	0.007	0	0	0.006	0.006	0.002	0.008	0.016	0	0	0	0.003	0	0	0	0	0
1981	0.008	0.001	0.012	0.004	0.005	0.009	0.002	0.005	0.008	0	0	0	0	0	0	0	0
1982	0.023	0.001	0	0.014	0.008	0.005	0.006	0.002	0.005	0.006	0	0	0	0	0	0	0

Table 3.5.4.1. cont. Norwegian spring spawning herring. Catch in numbers (billions).

YEAR	AGE																
	0	1	2	3	4	5	6	7	8	9	10	11	12	13	14	15	16
1983	0.127	0.005	0.002	0.003	0.021	0.01	0.006	0.007	0.001	0.005	0.007	0	0	0	0	0	0
1984	0.034	0.002	0.002	0.004	0.005	0.062	0.018	0.013	0.016	0.007	0.016	0.006	0	0	0	0.002	0
1985	0.029	0.013	0.207	0.022	0.016	0.017	0.13	0.059	0.055	0.063	0.01	0.031	0.05	0	0	0	0.003
1986	0.014	0.001	0.003	0.54	0.018	0.015	0.016	0.105	0.075	0.042	0.077	0.019	0.066	0.08	0	0	0.002
1987	0.014	0.006	0.036	0.02	0.501	0.019	0.004	0.007	0.028	0.012	0.01	0.005	0.008	0.007	0.007	0	0
1988	0.015	0.003	0.009	0.063	0.025	0.55	0.009	0.004	0.006	0.015	0.009	0.003	0.003	0.003	0.002	0	0
1989	0.007	0.002	0.025	0.003	0.004	0.006	0.324	0.003	0	0	0.003	0.001	0	0	0	0	0
1990	0.001	0	0.016	0.019	0.003	0.012	0.011	0.226	0.001	0.002	0.002	0.002	0	0	0	0	0
1991	0	0.003	0.003	0.008	0.003	0.001	0.015	0.009	0.219	0.002	0	0	0	0	0	0	0
1992	0.002	0	0.001	0.013	0.033	0.005	0.001	0.012	0.006	0.226	0.002	0	0	0.001	0	0	0
1993	0.007	0	0.007	0.028	0.107	0.087	0.009	0.004	0.03	0.019	0.41	0	0	0	0	0	0
1994	0	0	0.008	0.033	0.11	0.364	0.165	0.016	0.008	0.037	0.036	0.645	0.003	0	0	0.002	0
1995	0	0	0.001	0.058	0.346	0.623	0.638	0.231	0.016	0.016	0.07	0.084	0.912	0.004	0	0	0
1996	0	0	0.03	0.034	0.714	1.571	0.941	0.406	0.103	0.006	0.007	0.066	0.018	0.837	0	0	0
1997	0	0	0.022	0.13	0.271	1.796	1.994	0.761	0.326	0.061	0.02	0.032	0.091	0.019	0.37	0	0
1998	0	0	0.083	0.07	0.242	0.368	1.76	1.264	0.381	0.13	0.043	0.025	0.003	0.113	0.006	0.109	0
1999	0	0	0.005	0.138	0.036	0.135	0.429	1.605	1.164	0.291	0.106	0.015	0.04	0.007	0.089	0	0.064
2000	0	0	0.014	0.084	0.56	0.035	0.111	0.404	1.299	1.045	0.217	0.072	0.016	0.023	0.023	0.005	0.067
2001	0	0	0.002	0.102	0.161	0.427	0.039	0.096	0.296	0.839	0.507	0.074	0.024	0.004	0.003	0	0.022
2002	0	0	0.062	0.198	0.643	0.256	0.326	0.03	0.094	0.265	0.663	0.339	0.053	0.012	0.007	0	0.01
2003	0.000	0.003	0.005	0.075	0.324	0.730	0.176	0.168	0.023	0.074	0.217	0.567	0.219	0.039	0.008	0.006	0
2004	0.000	0.002	0.044	0.024	0.092	0.430	0.714	0.111	0.138	0.027	0.052	0.169	0.402	0.211	0.028	0.008	0.004
2005	0.000	0.000	0.020	0.435	0.094	0.163	0.634	0.940	0.120	0.124	0.035	0.066	0.144	0.352	0.129	0.011	0.005

Table 3.5.4.2 Norwegian Spring Spawning Herring Landings in numbers ('000) by length group and quarters in the Norwegian Sea 2005.

Length (cm)	Quarter 1	Quarter 2	Quarter 3	Quarter 4	All year
17	197			94	292
18	263			142	405
19	66			142	207
20	386	11	304	94	795
21	774	34	152	425	1 385
22	452	22	472	2 392	3 337
23	840	44	799	4 104	5 787
24	3 158	49	1 155	9 283	13 645
25	5 301	163	2 844	22 680	30 989
26	3 491	441	6 408	55 160	65 500
27	8 650	710	8 297	94 971	112 627
28	15 771	1 007	9 682	122 746	149 206
29	79 540	1 179	11 194	130 996	222 909
30	219 669	2 751	14 882	91 167	328 469
31	304 241	6 654	33 835	98 718	443 448
32	286 757	10 359	71 566	228 950	597 632
33	207 634	11 839	133 391	355 079	707 943
34	190 400	8 449	113 021	343 729	655 599
35	133 880	6 055	93 878	340 584	574 396
36	53 610	4 734	94 975	251 989	405 308
37	15 520	2 320	71 118	105 499	194 457
38	4 160	633	22 989	19 306	47 087
39	780	84	2 453	2 471	5 788
40	197	13	304	531	1 045
TOTAL	1535 736	57 552	693 718	2281 252	4568 258
numbers					
Official Catch	231 754	102 966	288 852	379 671	1003 243
(t)					

Table 3.5.5.1. Norwegian spring spawning herring. Weight at age in the catch (kg).

YEAR	AGE																
	0	1	2	3	4	5	6	7	8	9	10	11	12	13	14	15	16
1950	0.007	0.025	0.058	0.110	0.188	0.211	0.234	0.253	0.266	0.280	0.294	0.303	0.312	0.32	0.323	0.331	0.335
1951	0.009	0.029	0.068	0.130	0.222	0.249	0.276	0.298	0.314	0.330	0.346	0.357	0.368	0.377	0.381	0.390	0.395
1952	0.008	0.026	0.061	0.115	0.197	0.221	0.245	0.265	0.279	0.293	0.308	0.317	0.327	0.335	0.339	0.346	0.351
1953	0.008	0.027	0.063	0.120	0.205	0.230	0.255	0.275	0.290	0.305	0.320	0.330	0.34	0.347	0.351	0.359	0.364
1954	0.008	0.026	0.062	0.117	0.201	0.225	0.250	0.269	0.284	0.299	0.313	0.323	0.333	0.341	0.345	0.352	0.357
1955	0.008	0.027	0.063	0.119	0.204	0.229	0.254	0.274	0.289	0.304	0.318	0.328	0.338	0.346	0.350	0.358	0.363
1956	0.008	0.028	0.066	0.126	0.215	0.241	0.268	0.289	0.304	0.320	0.336	0.346	0.357	0.365	0.369	0.378	0.383
1957	0.008	0.028	0.066	0.127	0.216	0.243	0.269	0.290	0.306	0.322	0.338	0.348	0.359	0.367	0.371	0.380	0.385
1958	0.009	0.030	0.070	0.133	0.227	0.255	0.283	0.305	0.321	0.338	0.355	0.366	0.377	0.386	0.390	0.399	0.404
1959	0.009	0.030	0.071	0.135	0.231	0.259	0.287	0.310	0.327	0.344	0.360	0.372	0.383	0.392	0.397	0.406	0.411
1960	0.006	0.011	0.074	0.119	0.188	0.277	0.337	0.318	0.363	0.379	0.360	0.420	0.411	0.439	0.450	0.444	0.448
1961	0.006	0.010	0.045	0.087	0.159	0.276	0.322	0.372	0.363	0.393	0.407	0.397	0.422	0.447	0.465	0.452	0.452
1962	0.009	0.023	0.055	0.085	0.148	0.288	0.333	0.360	0.352	0.350	0.374	0.384	0.374	0.394	0.399	0.411	0.416
1963	0.008	0.026	0.047	0.098	0.171	0.275	0.268	0.323	0.329	0.336	0.341	0.358	0.385	0.353	0.381	0.386	0.386
1964	0.009	0.024	0.059	0.139	0.219	0.239	0.298	0.295	0.339	0.350	0.358	0.351	0.367	0.375	0.372	0.427	0.434
1965	0.009	0.016	0.048	0.089	0.217	0.234	0.262	0.331	0.360	0.367	0.386	0.395	0.393	0.404	0.401	0.429	0.437
1966	0.008	0.017	0.040	0.063	0.246	0.260	0.265	0.301	0.410	0.425	0.456	0.460	0.467	0.446	0.459	0.465	0.474
1967	0.009	0.015	0.036	0.066	0.093	0.305	0.305	0.310	0.333	0.359	0.413	0.446	0.401	0.408	0.439	0.427	0.431
1968	0.010	0.027	0.049	0.075	0.108	0.158	0.375	0.383	0.364	0.382	0.441	0.410		0.517	0.491	0.464	0.487
1969	0.009	0.021	0.047	0.072		0.152	0.296		0.329	0.329	0.341						0.429
1970	0.008	0.058	0.085	0.105	0.171		0.216	0.277	0.298	0.304	0.305	0.309					0.376
1971	0.011	0.053	0.121	0.177	0.216	0.250		0.305	0.333		0.366	0.377	0.388				
1972	0.011	0.029	0.062	0.103	0.154	0.215	0.258		0.322								
1973	0.006	0.053	0.106	0.161	0.213		0.255										
1974	0.006	0.055	0.117			0.249											
1975	0.009	0.079	0.169	0.241			0.381										
1976	0.007	0.062	0.132	0.189	0.250			0.323									
1977	0.011	0.091	0.193	0.316	0.350				0.511								
1978	0.012	0.100	0.210	0.274	0.424	0.454				0.613							
1979	0.010	0.088	0.181	0.293	0.359	0.416	0.436				0.553						
1980	0.012			0.266	0.399	0.449	0.460	0.485				0.608					
1981	0.010	0.082	0.163	0.196	0.291	0.341	0.368	0.380	0.397								
1982	0.010	0.087	0.159	0.256	0.312	0.378	0.415	0.435	0.449	0.448							

Table 3.5.5.1. cont. Norwegian spring spawning herring. Weight at age in the catch (kg).

YEAR	AGE																
	0	1	2	3	4	5	6	7	8	9	10	11	12	13	14	15	16
1983	0.011	0.090	0.165	0.217	0.265	0.337	0.378	0.410	0.426	0.435	0.444						
1984	0.009	0.047	0.145	0.218	0.262	0.325	0.346	0.381	0.400	0.413	0.405	0.426				0.415	
1985	0.009	0.022	0.022	0.214	0.277	0.295	0.338	0.360	0.381	0.397	0.409	0.417	0.435				0.435
1986	0.007	0.077	0.097	0.055	0.249	0.294	0.312	0.352	0.374	0.398	0.402	0.401	0.410	0.410			0.410
1987	0.010	0.075	0.091	0.124	0.173	0.253	0.232	0.312	0.328	0.349	0.353	0.370	0.385	0.385	0.385		
1988	0.008	0.062	0.075	0.124	0.154	0.194	0.241	0.265	0.304	0.305	0.317	0.308	0.334	0.334	0.334		
1989	0.010	0.060	0.204	0.188	0.264	0.260	0.282	0.306			0.422	0.364					
1990	0.007		0.102	0.230	0.239	0.266	0.305	0.308	0.376	0.407	0.412	0.424					
1991		0.015	0.104	0.208	0.250	0.288	0.312	0.316	0.330	0.344							
1992	0.007		0.103	0.191	0.233	0.304	0.337	0.365	0.361	0.371	0.403			0.404			
1993	0.007		0.106	0.153	0.243	0.282	0.320	0.330	0.365	0.373	0.379						
1994			0.102	0.194	0.239	0.280	0.317	0.328	0.356	0.372	0.390	0.379	0.399	0.403			
1995			0.102	0.153	0.192	0.234	0.283	0.328	0.349	0.356	0.374	0.366	0.393	0.387			
1996			0.136	0.136	0.168	0.206	0.262	0.309	0.337	0.366	0.360	0.361	0.367	0.379			
1997			0.089	0.167	0.184	0.207	0.232	0.277	0.305	0.331	0.328	0.344	0.343	0.397	0.357		
1998			0.111	0.150	0.216	0.221	0.249	0.277	0.316	0.338	0.374	0.372	0.366	0.396	0.377	0.406	
1999			0.096	0.173	0.228	0.262	0.274	0.292	0.307	0.335	0.362	0.371	0.399	0.396	0.400		0.404
2000			0.124	0.175	0.222	0.242	0.289	0.303	0.310	0.328	0.349	0.383	0.411	0.410	0.419	0.409	0.409
2001			0.105	0.166	0.214	0.252	0.268	0.305	0.308	0.322	0.337	0.363	0.353	0.378	0.400		0.427
2002			0.056	0.128	0.198	0.255	0.281	0.303	0.322	0.323	0.334	0.345	0.369	0.407	0.410		0.435
2003		0.062	0.068	0.169	0.218	0.257	0.288	0.316	0.323	0.348	0.354	0.351	0.363	0.372	0.376	0.429	0.429
2004	0.022	0.066	0.143	0.18	0.227	0.26	0.29	0.323	0.355	0.375	0.383	0.399	0.395	0.405	0.429	0.439	0.439
2005		0.092	0.103	0.180	0.234	0.266	0.291	0.315	0.345	0.367	0.389	0.372	0.383	0.398	0.402	0.413	0.413

Table 3.5.5.2. Norwegian spring spawning herring. Weight at age in the stock (kg).

YEAR	AGE																
	0	1	2	3	4	5	6	7	8	9	10	11	12	13	14	15	16
1950	0.001	0.008	0.047	0.100	0.204	0.230	0.255	0.275	0.290	0.305	0.315	0.325	0.330	0.340	0.345	0.362	0.365
1951	0.001	0.008	0.047	0.100	0.204	0.230	0.255	0.275	0.290	0.305	0.315	0.325	0.330	0.340	0.345	0.362	0.365
1952	0.001	0.008	0.047	0.100	0.204	0.230	0.255	0.275	0.290	0.305	0.315	0.325	0.330	0.340	0.345	0.362	0.365
1953	0.001	0.008	0.047	0.100	0.204	0.230	0.255	0.275	0.290	0.305	0.315	0.325	0.330	0.340	0.345	0.362	0.365
1954	0.001	0.008	0.047	0.100	0.204	0.230	0.255	0.275	0.290	0.305	0.315	0.325	0.330	0.340	0.345	0.362	0.365
1955	0.001	0.008	0.047	0.100	0.195	0.213	0.260	0.275	0.290	0.305	0.315	0.325	0.330	0.340	0.345	0.362	0.365
1956	0.001	0.008	0.047	0.100	0.205	0.230	0.249	0.275	0.290	0.305	0.315	0.325	0.330	0.340	0.345	0.362	0.365
1957	0.001	0.008	0.047	0.100	0.136	0.228	0.255	0.262	0.290	0.305	0.315	0.325	0.330	0.340	0.345	0.362	0.365
1958	0.001	0.008	0.047	0.100	0.204	0.242	0.292	0.295	0.293	0.305	0.315	0.330	0.340	0.345	0.352	0.360	0.365
1959	0.001	0.008	0.047	0.100	0.204	0.252	0.260	0.290	0.300	0.305	0.315	0.325	0.330	0.340	0.345	0.355	0.360
1960	0.001	0.008	0.047	0.100	0.204	0.270	0.291	0.293	0.321	0.318	0.320	0.344	0.349	0.370	0.379	0.375	0.380
1961	0.001	0.008	0.047	0.100	0.232	0.250	0.292	0.302	0.304	0.323	0.322	0.321	0.344	0.357	0.363	0.365	0.370
1962	0.001	0.008	0.047	0.100	0.219	0.291	0.300	0.316	0.324	0.326	0.335	0.338	0.334	0.347	0.354	0.358	0.358
1963	0.001	0.008	0.047	0.100	0.185	0.253	0.294	0.312	0.329	0.327	0.334	0.341	0.349	0.341	0.358	0.375	0.375
1964	0.001	0.008	0.047	0.100	0.194	0.213	0.264	0.317	0.363	0.353	0.349	0.354	0.357	0.359	0.365	0.402	0.402
1965	0.001	0.008	0.047	0.100	0.186	0.199	0.236	0.260	0.363	0.350	0.370	0.360	0.378	0.387	0.390	0.394	0.394
1966	0.001	0.008	0.047	0.100	0.185	0.219	0.222	0.249	0.306	0.354	0.377	0.391	0.379	0.378	0.361	0.383	0.383
1967	0.001	0.008	0.047	0.100	0.180	0.228	0.269	0.270	0.294	0.324	0.420	0.430	0.366	0.368	0.433	0.414	0.414
1968	0.001	0.008	0.047	0.100	0.115	0.206	0.266	0.275	0.274	0.285	0.350	0.325	0.363	0.408	0.388	0.378	0.378
1969	0.001	0.008	0.047	0.100	0.115	0.145	0.270	0.300	0.306	0.308	0.318	0.340	0.368	0.360	0.393	0.397	0.397
1970	0.001	0.008	0.047	0.100	0.209	0.272	0.230	0.295	0.317	0.323	0.325	0.329	0.380	0.370	0.380	0.391	0.391
1971	0.001	0.015	0.080	0.100	0.190	0.225	0.250	0.275	0.290	0.310	0.325	0.335	0.345	0.355	0.365	0.390	0.390
1972	0.001	0.010	0.070	0.150	0.150	0.140	0.210	0.240	0.270	0.300	0.325	0.335	0.345	0.355	0.365	0.390	0.390
1973	0.001	0.010	0.085	0.170	0.259	0.342	0.384	0.409	0.404	0.461	0.520	0.534	0.500	0.500	0.500	0.500	0.500
1974	0.001	0.010	0.085	0.170	0.259	0.342	0.384	0.409	0.444	0.461	0.520	0.543	0.482	0.482	0.482	0.482	0.482
1975	0.001	0.010	0.085	0.181	0.259	0.342	0.384	0.409	0.444	0.461	0.520	0.543	0.482	0.482	0.482	0.482	0.482
1976	0.001	0.010	0.085	0.181	0.259	0.342	0.384	0.409	0.444	0.461	0.520	0.543	0.482	0.482	0.482	0.482	0.482
1977	0.001	0.010	0.085	0.181	0.259	0.343	0.384	0.409	0.444	0.461	0.520	0.543	0.482	0.482	0.482	0.482	0.482
1978	0.001	0.010	0.085	0.180	0.294	0.326	0.371	0.409	0.461	0.476	0.520	0.543	0.500	0.500	0.500	0.500	0.500
1979	0.001	0.010	0.085	0.178	0.232	0.359	0.385	0.420	0.444	0.505	0.520	0.551	0.500	0.500	0.500	0.500	0.500
1980	0.001	0.010	0.085	0.175	0.283	0.347	0.402	0.421	0.465	0.465	0.520	0.534	0.500	0.500	0.500	0.500	0.500
1981	0.001	0.010	0.085	0.170	0.224	0.336	0.378	0.387	0.408	0.397	0.520	0.543	0.512	0.512	0.512	0.512	0.512
1982	0.001	0.010	0.085	0.170	0.204	0.303	0.355	0.383	0.395	0.413	0.453	0.468	0.506	0.506	0.506	0.506	0.506

Table 3.5.5.2. cont. Norwegian spring spawning herring. Weight at age in the stock (kg).

YEAR	AGE																
	0	1	2	3	4	5	6	7	8	9	10	11	12	13	14	15	16
1983	0.001	0.010	0.085	0.155	0.249	0.304	0.368	0.404	0.424	0.437	0.436	0.493	0.495	0.495	0.495	0.495	0.495
1984	0.001	0.010	0.085	0.140	0.204	0.295	0.338	0.376	0.395	0.407	0.413	0.422	0.437	0.437	0.437	0.437	0.437
1985	0.001	0.010	0.085	0.148	0.234	0.265	0.312	0.346	0.370	0.395	0.397	0.428	0.428	0.428	0.428	0.428	0.428
1986	0.001	0.010	0.085	0.054	0.206	0.265	0.289	0.339	0.368	0.391	0.382	0.388	0.395	0.395	0.395	0.395	0.395
1987	0.001	0.010	0.055	0.090	0.143	0.241	0.279	0.299	0.316	0.342	0.343	0.362	0.376	0.376	0.376	0.376	0.376
1988	0.001	0.015	0.050	0.098	0.135	0.197	0.277	0.315	0.339	0.343	0.359	0.365	0.376	0.376	0.376	0.376	0.376
1989	0.001	0.015	0.100	0.154	0.175	0.209	0.252	0.305	0.367	0.377	0.359	0.395	0.396	0.396	0.396	0.396	0.396
1990	0.001	0.008	0.048	0.219	0.198	0.258	0.288	0.309	0.428	0.370	0.403	0.387	0.440	0.440	0.440	0.440	0.440
1991	0.001	0.011	0.037	0.147	0.210	0.244	0.300	0.324	0.336	0.343	0.382	0.366	0.425	0.425	0.425	0.425	0.425
1992	0.001	0.007	0.030	0.128	0.224	0.296	0.327	0.355	0.345	0.367	0.341	0.361	0.430	0.470	0.470	0.470	0.450
1993	0.001	0.008	0.025	0.081	0.201	0.265	0.323	0.354	0.358	0.381	0.369	0.396	0.393	0.374	0.403	0.400	0.400
1994	0.001	0.010	0.025	0.075	0.151	0.254	0.318	0.371	0.347	0.412	0.382	0.407	0.410	0.410	0.410	0.410	0.410
1995	0.001	0.018	0.025	0.066	0.138	0.230	0.296	0.346	0.388	0.363	0.409	0.414	0.422	0.410	0.410	0.405	0.447
1996	0.001	0.018	0.025	0.076	0.118	0.188	0.261	0.316	0.346	0.374	0.390	0.390	0.384	0.398	0.398	0.398	0.398
1997	0.001	0.018	0.025	0.096	0.118	0.174	0.229	0.286	0.323	0.370	0.378	0.386	0.360	0.393	0.391	0.391	0.391
1998	0.001	0.018	0.025	0.074	0.147	0.174	0.217	0.242	0.278	0.304	0.310	0.359	0.340	0.344	0.385	0.363	0.375
1999	0.001	0.018	0.025	0.102	0.150	0.223	0.240	0.264	0.283	0.315	0.345	0.386	0.386	0.386	0.382	0.382	0.407
2000*	0.001	0.018	0.025	0.119	0.178	0.225	0.271	0.285	0.298	0.311	0.339	0.390	0.398	0.406	0.414	0.422	0.431
2001	0.001	0.018	0.025	0.075	0.178	0.238	0.247	0.296	0.307	0.314	0.328	0.351	0.376	0.406	0.414	0.425	0.425
2002	0.001	0.010	0.023	0.057	0.177	0.241	0.275	0.302	0.311	0.314	0.328	0.341	0.372	0.405	0.415	0.467	0.409
2003	0.001	0.010	0.055	0.098	0.159	0.211	0.272	0.305	0.292	0.331	0.337	0.347	0.356	0.381	0.414	0.425	0.441
2004	0.001	0.010	0.055	0.106	0.149	0.212	0.241	0.279	0.302	0.337	0.354	0.355	0.360	0.371	0.400	0.412	0.445
2005	0.001	0.010	0.046	0.112	0.156	0.234	0.267	0.295	0.330	0.363	0.377	0.414	0.406	0.308	0.420	0.452	0.452
2006	0.001	0.010	0.042	0.107	0.179	0.232	0.272	0.297	0.318	0.371	0.365	0.393	0.395	0.399	0.415	0.422	0.434

*values in 2000 changed to values in the report from 2000.

Table 3.6.1.1.1. Norwegian Spring-spawning herring. Estimates from the acoustic surveys on the spawning stock in February-March. Numbers in millions.

YEAR	AGE														TOTAL
	2	3	4	5	6	7	8	9	10	11	12	13	14	15+	
1988		255	146	6805	202										7408
1989	101	5	373	103	5402	182									6166
1990	183	187	0	345	112	4489	146								5462
1991	44	59	54	12	354	122	4148	102							4895
1992*															
1993*															
1994	16	128	676	1375	476	63	13	140	35	1820					4742
1995		1792	7621	3807	2151	322	20	1	124	63	2573				18474
1996	407	231	7638	11243	2586	957	471	0	0	165	0	2024			25756
1997*															
1998			381	1905	10640	6708	1280	434	130	39	0	175	0	804	22496
1999	106	1366	337	1286	2979	11791	7534	1912	568	132	0	0	392	437	28840
2000	1516	690	1996	164	592	1997	7714	4240	553	71	3	0	6	361	19903
2001**															
2002**															
2003**															
2004**															
2005	103	281	811	3310	7545	10453	887	563	159	122	610	1100	686	17	26649
2006	13	75	10167	684	1103	4540	4407	133	47	11	113	120	323	135	21871

* No estimate due to poor weather conditions.

** No surveys.

Table 3.6.1.2.1. Norwegian Spring-spawning herring. Estimates obtained on the acoustic surveys in the wintering areas in November-December. Numbers in millions.

YEAR	AGE														TOTAL
	1	2	3	4	5	6	7	8	9	10	11	12	13	14+	
1992		36	1247	1317	173	16	208	139	3742	69					6947
1993	72	1518	2389	3287	1267	13	13	158	26	4435					13178
1994		16	3708	4124	2593	1096	34	25	196	29	3239				15209
1995	380	183	5133	5274	1839	1040	308	19	13	111	39	907			15246
1996		1465	3008	13180	5637	994	552	92	0	7	41	15	393		25384
1997	9	73	661	1480	6110	4458	1843	743	66	0	0	126	0	842	16411
1998	65	1207	441	1833	3869	12052	8242	2068	629	111	14	0	392	221	31144
1999	74	159	2425	296	837	2066	6601	4168	755	212	0	15	0	146	17754
2000	56	322	1522	5260	165	497	1869	4785	3635	668	205	0	0	168	19152
2001	362	522	3916	1528	2615	82	338	864	3160	2216	384	127	0	18	16132
2002*	7	50	276	1659	624	1029	32	188	516	1831	911	184	0	0	7345
2003**	586	406	2167	10670	13237	1047	678	41	134	301	1214	502	10	37	31030
2004**	257	6814	1123	1596	5334	6731	363	280	37	42	187	761	392	83	24000
2005	61	352	7173	465	685	2030	3101	177	190	57	46	184	476	327	15325

* Much of the youngest yearclasses (-98,-99) wintered outside the fjords this winter and are not included in the estimate

** In 2003-2004 a combined estimate from the Tysfjord, Ofotfjord and oceanic areas off Vesterålen/Troms.

Table 3.6.1.2.2. Norwegian spring spawning herring. Estimates obtained on the acoustic surveys in the wintering areas in January. Numbers in millions.

YEAR	AGE														TOTAL
	2	3	4	5	6	7	8	9	10	11	12	13	14	15+	
1991	90	220	70	20	180	150	5500	440							6670
1992		410	820	260	60	510	120	4690	30						6900
1993		61	1905	2048	256	27	269	182	5691	128					10567
1994	73	642	3431	4847	1503	102	29	161	131	3679					14598
1995		47	3781	4013	2445	1215	42	24	267	29	4326				16189
1996		315	10442	13557	4312	1271	290	22	25	200	58	1146			31638
1997*															-
1998	214	267	1938	4162	9647	6974	1518	743	16	4	0	181	7	314	25985
1999**	0	1358	199	1455	4452	12971	7226	1876	499	16	16	0	156	220	30444

* No estimate due to poor weather conditions.

** No surveys since 1999.

Table 3.6.1.3.1. Norwegian spring spawning herring. Estimates from the international acoustic surveys on the feeding areas in the Norwegian Sea in May. Numbers in millions.

YEAR	AGE															TOTAL
	1	2	3	4	5	6	7	8	9	10	11	12	13	14	15+	
1996	0	0	4114	22461	13244	4916	2045	424	14	7	155	0	3134			50514
1997	0	0	1169	3599	18867	13546	2473	1771	178	77	288	415	60	2472		44915
1998	24	1404	367	1099	4410	16378	10160	2059	804	183	0	0	112	0	415	37415
1999	0	215	2191	322	965	3067	11763	6077	853	258	5	14	0	158	128	26016
2000	0	157	1353	2783	92	384	1302	7194	5344	1689	271	0	114	0	1135	21857
2001	0	1540	8312	1430	1463	179	204	3215	5433	1220	94	178	0	0	85	23353
2002	0	677	6343	9619	1418	779	375	847	1941	2500	1423	61	78	28	26	26142
2003	32073	8115	6561	9985	9961	1499	732	146	228	1865	2359	1769		287	45	75625
2004	0	13735	1543	5227	12571	10710	1075	580	76	313	362	1294	1120	10	88	48704
2005	0	1293	19679	1353	1765	6205	5371	651	388	139	262	526	1003	364	115	39114
2006	0	19	306	14560	1396	2011	6521	6978	679	713	173	407	921	618	243	35545

Table 3.6.1.4.1. Norwegian spring-spawning herring. Acoustic estimates (billion individuals) of immature herring in the Barents Sea in May/June. No survey in 2003, 1990-2002. See footnotes.

YEAR	AGE				
	1	2	3	4	5
1991	24.3	5.2			
1992	32.6	14	5.7		
1993	102.7	25.8	1.5		
1994	6.6	59.2	18	1.7	
1995	0.5	7.7	8	1.1	
1996 ¹	0.1	0.25	1.8	0.6	0.03
1997 ²	2.6	0.04	0.4	0.35	0.05
1998	9.5	4.7	0.01	0.01	0
1999	49.5	4.9	0	0	0
2000	105.4	27.9	0	0	0
2001	0.3	7.6	8.8	0	0
2002	0.5	3.9	0	0	0
2003 ³					
2004 ³					
2005	23.3	4.5	2.5	0.4	0.3
2006	3.7	35.0	5.3	0.87	0

¹ Average of Norwegian and Russian estimates

² Combination of Norwegian and Russian estimates as described in 1998 WG report, since then only Russian estimates

³ No surveys

Table 3.6.1.4.2. Norwegian spring-spawning herring. Abundance indices for 0-group herring 1980-2005 (replacing the log index in 3.6.1.4.4).

YEAR	ABUNDANCE INDEX
1980	5
1981	3
1982	49
1983	32830
1984	4258
1985	7858
1986	9
1987	2
1988	8946
1989	4113
1990	4541
1991	79417
1992	39073
1993	68077
1994	18918
1995	1700
1996	59120
1997	46833
1998	79577
1999	16525
2000	49710
2001	852
2002	23494
2003	31400
2004	138995
2005	26361

Table 3.6.1.4.3. Norwegian spring-spawning herring. Acoustic estimates (billion individuals) of immature herring in the Barents Sea in August-October. 0-group in separate table (Table 3.6.1.4.4).

Year	age		
	1	2	3
2000	14.7	11.5	0
2001	0.5	10.5	1.7
2002	1.3	0	0
2003	99.9	4.3	2.5
2004	14.3	36.5	0.9
2005	46.4	16.1	7.0

Table 3.6.1.4.4. Norwegian spring spawners. Acoustic abundance (TS = 20 logL - 71.9) of 0-group herring in Norwegian coastal waters in 1975–2004 (numbers in millions).

YEAR	AREA				TOTAL
	SOUTH OF 62°N	62°N-65°N	65°N -68°N	NORTH OF 68°30'N	
1975		164	346	28	538
1976		208	1 305	375	1 888
1977		35	153	19	207
1978		151	256	196	603
1979		455	1 130	144	1 729
1980		6	2	109	117
1981		132	1	1	134
1982		32	286	1 151	1 469
1983		162	2 276	4 432	6 866
1984		2	234	465	701
1985		221	177	104	502
1986		5	72	127	204
1987		327	26	57	410
1988		14	552	708	1 274
1989		575	263	2 052	2 890
1990		75	146	788	1 009
1991		80	299	2 428	2 807
1992	73	1 993	204	621	2 891
1993	290	109	140	288	827
1994	157	452	323	6 168	7 101
1995	0	27	2	0	29
1996	0	20	114	8 800	8 934
1997	208	69	544	5 244	6 065
1998	424	273	442	11 640	12 779
1999	121	658	271	6 329	7 379
2000	570	127	996	7 237	8 930
2001	89	324	134	1421	1968
2002	67	1227	284	3573	5151
*	SOUTH OF 62°N	62°N-64°N	64°N -67°N	NORTH OF 67°N	
2003	9	44	6647	21417	28117
2004	19	884	1306	11950	14159

* A new survey design was introduced in 2003, which resulted in changed areas and wider and denser coverage of the fjords. Thus the estimates from 2003 and onwards are likely to be higher and not directly comparable to the former estimates.

In 2005 the coverage was strongly hampered by vessel breakdown, therefore no figures were given.

Table 3.6.1.5.1. Norwegian Spring-spawning herring. The indices for herring larvae on the Norwegian shelf for the period 1981-2003 ($N \cdot 10^{-12}$).

YEAR	INDEX1	INDEX 2
1981	0.3	
1982	0.7	
1983	2.5	
1984	1.4	
1985	2.3	
1986	1	
1987	1.3	4
1988	9.2	25.5
1989	13.4	28.7
1990	18.3	29.2
1991	8.6	23.5
1992	6.3	27.8
1993	24.7	78
1994	19.5	48.6
1995	18.2	36.3
1996	27.7	81.7
1997	66.6	147.5
1998	42.4	138.6
1999	19.9	73
2000	19.8	89.4
2001	40.7	135.9
2002	27.1	138.6
2003	3.7	18.8
2004	56.4	215.1
2005	73.91	196.7
2006	98.9	389.0

Index 1. The total number of herring larvae found during the cruise.

Index 2. Back-calculated number of newly hatched larvae with 10% daily mortality. The larval age is estimated from the duration of the yolk sac stages and the size of the larvae.

Table 3.6.2.1. Tagging data for Norwegian spring spawning herring. Tagging data for the 1983 year class.

Year	Number screened	2002 release		2000 release		1998 release		1997 release		1996 release		1995 release		1994 release		1993 release		1992 release		1991 release		1990 release		1989 release		1988 release		1987 release		
		Released	Recovered	Released	Recovered	Released	Recovered	Released	Recovered	Released	Recovered	Released	Recovered	Released	Recovered	Released	Recovered	Released	Recovered	Released	Recovered	Released	Recovered	Released	Recovered	Released	Recovered	Released	Recovered	
1987																												33067	0	
1988																												38152	27	78
1989	10695																							20620	0		17		12	
1990	5489																						24585	34	4		10		4	
1991	5545																				12558	0		4		5		7	1	
1992	1737																		15262	0		2		2		2		0	4	
1993	9372																15839	1		8		9		12		6		13	6	
1994	9474														5364	0		9		11		4		8		7		10	2	
1995	11554												859	0		4		7		9		6		15		5		10	6	
1996	4038										2879	3		0		3		4		1		2		10		6		2	3	
1997	3867								2 266	0		1		0		0		0		3		2		3		2		3	0	
1998	509					648	0		0		1		0		0		0		2		2		1		1		3		1	
1999	379						1		1		0		0		0		1		0		0		1		1		0		0	
2000	413			0	0		0		0		0		0		0		0		1		0		3		0		1		0	
2001	35						0		0		0		0		0		0		0		0		0		0		1		0	
2002	221	0	0				0		0		0		0		0		0		0		0		0		0		1		0	
2003	0		0				0		0		0		0		0		0		0		0		0		0		0		0	
2004	0		0				0		0		0		0		0		0		0		0		0		0		0		0	
2005	0		0				0		0		0		0		0		0		0		0		0		1		0		0	

* tagging data for 2002 was considered an outlier and thus not included in the analysis

Table 3.6.2.1, cont. Norwegian spring spawning herring. Tagging data for the 1984 year class

Year	Number screened	2002 release		2000 release		1998 release		1997 release		1996 release		1995 release		1994 release		1993 release		1992 release		1991 release		1990 release		1989 release		1988 release	
		Released	Recovered	Released	Recovered	Released	Recovered	Released	Recovered	Released	Recovered	Released	Recovered	Released	Recovered	Released	Recovered	Released	Recovered	Released	Recovered	Released	Recovered	Released	Recovered	Released	Recovered
1988																										1342	1
1989																									1175	0	0
1990	157																					1097	0	0	0	0	0
1991	138																		257	0	1	0	0	0	0	0	0
1992	30																	767	0	0	0	0	0	0	0	0	0
1993	287															479	0	1	0	1	1	1	1	1	1	2	2
1994	267													160	0	0	0	1	2	0	0	0	0	0	0	0	0
1995	264											56	0	1	0	0	0	0	0	0	0	0	0	0	0	0	0
1996	281										113	0	0	0	0	0	0	0	0	0	0	0	0	0	0	0	0
1997	0						0	0	0	0	0	0	0	0	0	0	0	0	0	0	0	0	0	0	0	0	0
1998	1				0	0	0	0	0	0	0	0	0	0	0	0	0	0	0	0	0	0	0	0	0	0	0
1999	0				0	0	0	0	0	0	0	0	0	0	0	0	0	0	0	0	0	0	0	0	0	0	0
2000	0			0	0	0	0	0	0	0	0	0	0	0	0	0	0	0	0	0	0	0	0	0	0	0	0
2001	0			0	0	0	0	0	0	0	0	0	0	0	0	0	0	0	0	0	0	0	0	0	0	0	0
2002	0	0	0	0	0	0	0	0	0	0	0	0	0	0	0	0	0	0	0	0	0	0	0	0	0	0	0
2003	0		0	0	0	0	0	0	0	0	0	0	0	0	0	0	0	0	0	0	0	0	0	0	0	0	0
2004	0		0	0	0	0	0	0	0	0	0	0	0	0	0	0	0	0	0	0	0	0	0	0	0	0	0
2005	0		0	0	0	0	0	0	0	0	0	0	0	0	0	0	0	0	0	0	0	0	0	0	0	0	0

* tagging data for 2002 was considered an outlier and thus not included in the analysis

** Will not be updated after 2003.

Table 3.6.2.1 cont. Norwegian spring spawning herring. Tagging data for the 1985 year class

Year	Number screened	2002 release		2000 release		1998 release		1997 release		1996 release		1995 release		1994 release		1993 release		1992 release		1991 release		1990 release		1989 release	
		Released	Recovered	Released	Recovered	Released	Recovered	Released	Recovered	Released	Recovered	Released	Recovered	Released	Recovered	Released	Recovered	Released	Recovered	Released	Recovered	Released	Recovered	Released	Recovered
1989																								2982	0
1990																							1081	2	0
1991	355																		1154	0			1		0
1992	114																	851	0			0			0
1993	573															1465	0					1		1	1
1994	345													368	0							1		0	2
1995	735											167	0		1							2		0	0
1996	427										564	0			0							0		0	1
1997	888								555	0		1			1							3		2	0
1998	497					778	0			0					0							1		0	0
1999	623							2		1					0							0		0	1
2000	703			299	0			2		0					0				1			0		0	0
2001	139				0			1		0					0							0		0	1
2002	194	0	0		0			2		0					0							0		0	1
2003	105		0		0			0		0					0							1		0	0
2004	0		0		0			0		0					0							0		0	0
2005	20		0		0			0		0					0							0		0	0

*1985+ group

** tagging data for 2002 was considered an outlier and thus not included in the analysis

Table 3.6.2.1 cont. Norwegian spring spawning herring. Tagging data for the 1986 year class

Year	Number screened	2002 release		2000 release		1998 release		1997 release		1996 release		1995 release		1994 release		1993 release		1992 release		1991 release		1990 release	
		Released	Recovered	Released	Recovered	Released	Recovered	Released	Recovered	Released	Recovered	Released	Recovered	Released	Recovered	Released	Recovered	Released	Recovered	Released	Recovered	Released	Recovered
1990																						381	0
1991																					165	0	0
1992	17																	210	0		0		0
1993	19															52	0		1		0		0
1994	65													256	0		0		0		0		0
1995	104										0	0		0		0		0		0		0	1
1996	92									213	0		0		0		0		1		0		0
1997	166							15	0		0		0		0		0		0		0		0
1998	0					84	0		0		0		0		0		0		0		0		0
1999	0						0		0		0		0		0		0		0		0		0
2000	3			0	0		0		0		0		0		0		0		0		0		0
2001	0				0		0		0		0		0		0		0		0		0		0
2002	10	0	0		0		0		0		0		0		0		0		0		0		0
2003	0		0		0		0		0		0		0		0		0		0		0		0
2004	0		0		0		0		0		0		0		0		0		0		0		0
2005	0		0		0		0		0		0		0		0		0		0		0		0

* tagging data for 2002 was considered an outlier and thus not included in the analysis

** Will not be updated after 2003.

Table 3.6.2.1 cont. Norwegian spring spawning herring. Tagging data for the 1987 year class

Year	Number screened	2002 release		2000 release		1998 release		1997 release		1996 release		1995 release		1994 release		1993 release		1992 release		1991 release	
		Released	Recovered	Released	Recovered	Released	Recovered	Released	Recovered	Released	Recovered	Released	Recovered	Released	Recovered	Released	Recovered	Released	Recovered	Released	Recovered
1991																				634	0
1992																		1146	0		0
1993	329															1569	0		2		0
1994	259													315	0		0		0		0
1995	90										27	0			1		1		0		1
1996	43									0	0				0		1		0		0
1997	224								135	0		0			0		0		0		0
1998	8					0	0					0				0			1		0
1999	81						0					0				0			0		0
2000	0			0	0		0					0				0			0		0
2001	22				0		0					0				0			0		0
2002	29	606	0		0		0					0				0			0		0
2003	0		0		0		0					0			1		0		0		0
2004	0		0		0		0					0			0		0		1		0
2005	0		0		0		0					0			0		0		0		0

*1987+group

** tagging data for 2002 was considered an outlier and thus not included in the analysis

Table 3.6.2.1 cont. Norwegian spring spawning herring. Tagging data for the 1988 year class

Year	Number screened	2002 release		2000 release		1998 release		1997 release		1996 release		1995 release		1994 release		1993 release		1992 release	
		Released	Recovered	Released	Recovered	Released	Recovered	Released	Recovered	Released	Recovered	Released	Recovered	Released	Recovered	Released	Recovered	Released	Recovered
1992																		5827	0
1993																5267	0		1
1994	3506													4473	0		2		3
1995	3729										1041	0		0		0			4
1996	1176									2109	1		0		2		3		3
1997	811							1940	0		0		0		0		0		0
1998	148					215	0		0		0		0		1		0		1
1999	12						0		0		0		0		0		0		0
2000	75			118			0		0		0		0		0		0		0
2001	0				0		0		0		0		0		0		1		0
2002	77	37	0		1		0		1		0		0		0		0		0
2003	2		0		0		0		0		0		0		0		0		0
2004	0		0		0		0		0		0		0		0		0		0
2005	0		0		0		0		0		0		0		0		0		0

** tagging data for 2002 was considered an outlier and thus not included in the analysis

Table 3.6.2.1 cont. Norwegian spring spawning herring. Tagging data for the 1989 year class

Year	Number screened	2002 release		2000 release		1998 release		1997 release		1996 release		1995 release		1994 release		1993 release	
		Released	Recovered	Released	Recovered	Released	Recovered	Released	Recovered	Released	Recovered	Released	Recovered	Released	Recovered	Released	Recovered
1993																7584	1
1994														11873			2
1995	9463										2348	2		10			4
1996	4636								5170	3		3		5			1
1997	3346							4103	0		2	0		7			2
1998	1183					1176	0			1		0		0			0
1999	1179						1		1		1		0		0		1
2000	790			470	0		1		0		0		0		2		0
2001	841				0		0		0		2		0		1		1
2002	286	319	0		0		1		0		0		0		0		0
2003	460		0		0		0		0		1		0		0		0
2004	758		0		0		0		0		0		0		0		0
2005	306		0		0		0		0		0		0		0		0

* tagging data for 2002 was considered an outlier and thus not included in the analysis

Table 3.6.2.1 cont. Norwegian spring spawning herring. Tagging data for the 1990 yearclass

Year	Number screened	2002 release		2000 release		1998 release		1997 release		1996 release		1995 release		1994 release	
		Released	Recovered	Released	Recovered	Released	Recovered	Released	Recovered	Released	Recovered	Released	Recovered	Released	Recovered
1994														10784	0
1995												3868	0		3
1996	9009									6171	3		3		9
1997	9830							4 057	2		3		3		7
1998	2828					2381	2		3		1		1		1
1999	3402						3		1		2		2		1
2000	3146			1219	0		1		0		2		2		0
2001	1 052				0		0		0		0		0		2
2002	1348	1 605	0		0		1		0		1		0		0
2003	1129		0		0		0		0		1		0		1
2004	1176		0		0		0		1		1		1		0
2005	183		0		0		1		0		0		0		0

* tagging data for 2002 was considered an outlier and thus not included in the analysis

Table 3.6.2.1 cont. Norwegian spring spawning herring. Tagging data for the 1991 year class

Year	Number screened	2002 release		2000 release		1998 release		1997 release		1996 release		1995 release	
		Released	Recovered	Released	Recovered	Released	Recovered	Released	Recovered	Released	Recovered	Released	Recovered
1995												21528	1
1996										25683	6		8
1997	30952							7 129	3		19		21
1998	12459					6002	0		2		6		8
1999	14968						6		4		14		7
2000	18461			3802	4		9		1		10		7
2001	10032				1		1		2		5		3
2002	8937	5 878	0		10		9		1		1		1
2003	9522		3		4		7		3		7		4
2004	14288		1		1		1		4		6		1
2005	6 517		1		0		2		2		2		1

* tagging data for 2002 was considered an outlier and thus not included in the analysis

Table 3.6.2.1 cont. Norwegian spring spawning herring. Tagging data for the 1992 year class

Year	Number screened	2002 release		2000 release		1998 release		1997 release		1996 release	
		Released	Recovered	Released	Recovered	Released	Recovered	Released	Recovered	Released	Recovered
1996										8417	0
1997								8 353	1		9
1998	20695					22320	11		7		7
1999	23790						27		9		4
2000	31430			16798	8		20		7		15
2001	14668				3		8		0		4
2002	17305	9995	0		12		23		2		1
2003	27306		6		11		11		4		9
2004	28022		10		19		17		2		7
2005	14667		2		6		7		0		2

* tagging data for 2002 was considered an outlier and thus not included in the analysis

Table 3.6.2.1 cont. Norwegian spring spawning herring. Tagging data for the 1993 year class

Year	Number screened	2002 release		2000 release		1998 release		1997 release	
		Released	Recovered	Released	Recovered	Released	Recovered	Released	Recovered
1997								976	0
1998						2015	3		0
1999	8046						3		0
2000	9099			2673	2		3		0
2001	3994				1		0		0
2002	5577	2 832	0		4		2		5
2003	6612		0		11		5		1
2004	7315		5		6		8		2
2005	4 546		2		3		1		0

* tagging data for 2002 was considered an outlier and thus not included in the analysis

Table 3.6.2.1 cont. Norwegian spring spawning herring. Tagging data for the 1994 year class

Year	Number screened	2002 release		2000 release		1998 release	
		Released	Recovered	Released	Recovered	Released	Recovered
1998						3752	2
1999							7
2000	2450			2278	1		1
2001	1104				0		1
2002	1588	1143	0		1		2
2003	2154		4		3		0
2004	1933		0		3		3
2005	1 087		1		0		1

* tagging data for 2002 was considered an outlier and thus not included in the analysis

Table 3.6.2.1 cont. Norwegian spring spawning herring. Tagging data for the 1995 year class

Year	Number screened	2002 release		2000 release	
		Released	Recovered	Released	Recovered
1999					
2000				505	0
2001	376				0
2002	250	197	0		1
2003	747		0		2
2004	829		0		0
2005	750		0		2

* tagging data for 2002 was considered an outlier and thus not included in the analysis

Table 3.6.2.1 cont. Norwegian spring spawning herring. Tagging data for the 1996 year class

Year	Number screened	2002 release		2000 release	
		Released	Recovered	Released	Recovered
2000				1 084	0
2001					0
2002	5 013	3379	0		0
2003	7 439		1		0
2004	6 903		1		0
2005	4 680		0		0

* tagging data for 2002 was considered an outlier and thus not included in the analysis

Table 3.6.2.1 cont. Norwegian spring spawning herring. Tagging data for the 1997 year class

Year	Number screened	2002 release	
		Released	Recovered
2001			
2002		1 869	0
2003	5 420		1
2004	3 678		0
2005	4 142		0

* tagging data for 2002 was considered an outlier and thus not included in the analysis

Table 3.6.2.1 cont. Norwegian spring spawning herring. Tagging data for the 1998 year class

Year	Number screened	2002 release	
		Released	Recovered
2002		3 561	0
2003	19 623		3
2004	18 332		1
2005	33 482		0

* tagging data for 2002 was considered an outlier and thus not included in the analysis

Table 3.7.2.1.1 Settings used in SeaStar.

	2005	2006
Year classes with free terminal Fs	1983,1990,1991,1992,1993,1996,1997,1998,1999,2002,2003,2004	As in 2006
Larvae observation model	Proportional, deletion of 2003 point	Logistic, deletion of 2003 point
Exclusion of survey data in addition to using selected age range	1998 year class in 2002 in survey 2 1999 year class in 2000 in survey 4 2002 in survey 6	In addition to settings in 2005: Years 2002-2005 in survey 2 Year 2005 in survey 3
Use of tagging data	Yes	No
Proportion of year before spawning	0.1	0.0
Error distribution model for surveys	Gamma for surveys 1,2,3,5, lognormal for surveys 4 and 6	As in 2005
Error distribution model for zerogroup data	Normal	Lognormal
Error distribution model for larval data	Gamma	Gamma
M	0.9 for ages 0,1,2, 0.5 for plus group, else 0.15	As in 2005

Table 3.7.2.1.2 Exploratory runs with SeaStar. Juv refers to the difference between the total stock and SSB in the stock biomass column and to herring in the Barents Sea in the survey log-likelihood column.

Run number	Stock biomass	Survey catchabilities	M	Survey log-likelihood	Larvae log-likelihood
1	SSB 11.15 Juv 1.87	S1 0.83, S2 0.76 S3 0.80, S4 0.33 S5 0.8, S6 0.33	0.90 0.15	Adult -236.64 Juv -122.05	-75.72
2	SSB 12.31 Juv 1.91	S1 0.74, S2 0.67 S3 0.77, S4 0.25 S5 0.79, S6 0.36	0.90 0.15	Adult -238.28 Juv -122.91	-82.09
3	SSB 10.39 Juv 1.85	S1 0.75, S2 0.80 S3 0.84, S4 0.34 S5 0.93, S6 0.34	0.90 0.15	Adult -244.11 Juv -121.92	-76.13
4	SSB 12.92 Juv 1.93	S1 0.72, S2 0.69 S3 0.76, S4 0.31 S5 0.75, S6 0.29	0.90 0.15	Adult -237.28 Juv -122.36	-81.63
5	SSB 15.57 Juv 2.01	S1 0.60, S2 0.57 S3 0.65, S4 0.29 S5 0.63, S6 0.25	0.90 0.15	Adult -243.60 Juv -122.37	-75.31
6	SSB 10.24 Juv 1.83	S1 0.80, S2 0.75 S3 0.81, S4 0.32 S5 0.86, S6 0.36	0.90 0.15	Adult -236.44 Juv -121.82	
8	Failed	Failed	Failed	Failed	Failed
9	SSB 11.30 Juv 1.90	S1 0.82, S2 0.72 S3 0.84, S4 0.33 S5 0.80, S6 0.32	0.90 0.15	Adult -241.68 Juv -121.89	-75.53
10	SSB 12.32 Juv 1.91	S1 0.64, S2 0.58 S3 0.76, S4 0.25 S5 0.80, S6 0.35	0.90 0.15	Adult -267.086 Juv -120.90	
11	SSB 9.01 Juv 1.80	S1 0.82, S2 0.75 S3 0.87, S4 0.29 S5 1.04, S6 0.43	0.90 0.15	Adult -254.70 Juv -121.108	-85.116
12	SSB 9.85 Juv 1.81	S1 0.73, S2 0.65 S3 0.81, S4 0.28 S5 0.91, S6 0.41	0.90 0.15	Adult -261.99 Juv -120.87	

Table 3.7.2.2.1 TISVPA results for NSS herring.

year	B(1+)	SSB (Jan.1)	SSB (sp.time)	R(1)	F(5-14, w-d by N(a))
1986	2763.83	406.44	340.98	13722.24	1.242
1987	3069.85	791.85	750.83	3147.71	0.375
1988	3584.9	2430.92	2318.1	3870.23	0.052
1989	4006.99	2953.8	2846.97	10785.46	0.032
1990	4452.46	3142.49	3029.9	28138.76	0.025
1991	5444.33	3261.37	3153.95	45515.58	0.028
1992	6973.42	3166.51	3057.92	126978.4	0.033
1993	8195.8	3111.78	2983.28	167352.52	0.075
1994	9115.63	3593.5	3426.78	49215.04	0.149
1995	9301.43	4484.35	4251.9	17399.01	0.255
1996	9543.37	6137.25	5797.74	6749.06	0.211
1997	8323	7691.97	7112.12	32702.16	0.184
1998	9993.84	7201.53	6724.64	20385.17	0.151
1999	9283.61	6863.03	6432.46	124723.6	0.186
2000	8373.56	5695.08	5321.37	82828.81	0.208
2001	8801.64	5103.4	4848.84	25109.78	0.162
2002	11973.15	5320.61	4992.31	22506.93	0.165
2003	15048.04	6776.98	6453.08	269114.42	0.102
2004	14211.6	7469.3	7116.39	59997.84	0.090
2005	14026.01	8193.64	7762.87		0.121
2006		11988.4			

Table 3.7.2.2.2. TISVPA abundance for NSS herring.

	1	2	3	4	5	6	7	8	9	10	11	12	13	14	15	16+
1986	13722.24	1961.82	18757.82	177.16	62.61	62.29	223.79	117.39	64.59	95.7	35.72	82.52	93.14	0	0	1.99
1987	3147.71	5578.41	795.7	15644.03	135.78	39.97	38.77	95.2	31.46	16.63	10.94	13.12	9.79	5.95	0	0
1988	3870.23	1275.94	2245.06	666.31	13000.14	99.24	30.7	26.88	55.96	15.94	5.04	4.77	3.87	1.94	0	0
1989	10785.46	1571.6	513.02	1873.89	550.31	10679.07	77.07	22.71	17.57	34.25	5.37	0	0	0	0	0
1990	28138.76	4383.77	623.03	438.78	1609.16	468.09	8890.97	63.55	19.55	15.12	26.7	0	0	0	0	0
1991	45515.58	11440.36	1772.1	518.62	374.88	1373.89	392.68	7442.86	53.77	0	0	21.12	0	0	0	0
1992	126978.4	18503.34	4649.39	1517.84	443.59	321.73	1168.6	329.63	6202.95	44.43	0	0	18.18	0	0	0
1993	167352.5	51625.56	7522.26	3989.71	1275.8	377.17	275.99	994.69	278.15	5129.26	36.38	0	0	14.72	0	0
1994	49215.04	68040.46	20984.92	6448.49	3334.71	1017.38	316.28	233.83	828.3	221.78	4034.42	31.31	0	0	12.67	0
1995	17399.01	20009.34	27658.08	18031.28	5448.22	2532.51	722.59	257.38	193.84	678.6	157.49	2874.06	24.17	0	0	0
1996	6749.06	7073.91	8134.55	23751.72	15198.66	4111.34	1587.85	407.63	206.69	152	519.14	57.62	1627.63	0	0	0
1997	32702.16	2743.96	2856.91	6969.93	19780.89	11624.13	2665.66	990.01	255.29	172.33	124.33	385.59	32.9	624.39	0	0
1998	20385.17	13295.71	1101.58	2338.36	5747.66	15359.34	8155.06	1588.34	549.67	163.14	129.77	77.32	247.46	10.69	194.15	0
1999	124723.6	8287.99	5352.71	883.2	1788.13	4605.64	11587.08	5846.46	1013.63	352.5	100.52	88.5	63.77	108.15	0	161.48
2000	82828.81	50708.83	3366.46	4479.09	726.78	1413.81	3566.11	8484.06	3952.2	602.46	205.05	72.6	39.06	48.39	10.52	167.93
2001	25109.78	33675.68	20607.75	2819.61	3335.65	593.07	1113.9	2694.57	6097.16	2432.2	317.22	109.69	47.65	12.28	0	107.31
2002	22506.93	10208.88	13690.24	17642.62	2277.49	2474.88	474.28	869.68	2044.63	4469.5	1623.04	204.38	72.15	37.3	0	32.54
2003	269114.4	9150.63	4111.09	11599.6	14588.61	1722.75	1827.7	380.38	661.33	1513.98	3231.84	1082.46	126.74	50.97	25.61	0
2004	59997.84	109411.9	3717.18	3468.86	9683.28	11879.28	1319.5	1417.26	306.06	500.56	1101.77	2255.64	728.51	72.91	36.45	21.71
2005	0	24392.02	44455.48	3177.14	2900.33	7935.55	9562.18	1032.73	1091.81	238.38	382.59	791.51	1568.49	431.28	36.78	19.91
2006	0	0	9904.3	37859.62	2647.38	2345.11	6242	7358.16	777.55	824.69	172.71	268.07	547.67	1023.45	251.53	21.45

Table 3.7.2.2.3. TISVPA Estimates of F(a,y) for NSS herring.

	1	2	3	4	5	6	7	8	9	10	11	12	13	14	15	16
1986	0.0001	0.0024	0.0315	0.1160	0.2987	0.3242	0.7047	1.1669	1.2069	2.0191	0.8516	1.9812	2.6007	0.0000	0.0000	1.2433
1987	0.0030	0.0102	0.0275	0.0351	0.1635	0.1141	0.2164	0.3813	0.5297	1.0446	0.6788	1.0707	1.4711	1.3166	0.0000	0.0000
1988	0.0012	0.0111	0.0307	0.0413	0.0467	0.1029	0.1514	0.2753	0.3409	0.9378	1.0276	1.1308	1.8041	2.1767	0.0000	0.0000
1989	0.0003	0.0253	0.0063	0.0023	0.0118	0.0333	0.0429	0.0000	0.0000	0.0992	0.2240	0.0000	0.0000	0.0000	0.0000	0.0000
1990	0.0000	0.0057	0.0334	0.0074	0.0081	0.0257	0.0278	0.0171	0.1169	0.1538	0.0842	0.0000	0.0000	0.0000	0.0000	0.0000
1991	0.0001	0.0004	0.0049	0.0063	0.0029	0.0118	0.0250	0.0322	0.0409	0.0000	0.0000	0.0000	0.0000	0.0000	0.0000	0.0000
1992	0.0000	0.0001	0.0030	0.0237	0.0122	0.0034	0.0111	0.0198	0.0401	0.0497	0.0000	0.0000	0.0611	0.0000	0.0000	0.0000
1993	0.0000	0.0002	0.0040	0.0293	0.0763	0.0261	0.0158	0.0331	0.0765	0.0901	0.0000	0.0000	0.0000	0.0000	0.0000	0.0000
1994	0.0000	0.0002	0.0017	0.0186	0.1252	0.1921	0.0561	0.0376	0.0494	0.1923	0.1891	0.1090	0.0000	0.0000	0.1865	0.0000
1995	0.0000	0.0001	0.0023	0.0209	0.1315	0.3168	0.4225	0.0694	0.0932	0.1179	0.8555	0.4186	0.1965	0.0000	0.0000	0.0000
1996	0.0000	0.0067	0.0045	0.0329	0.1181	0.2833	0.3224	0.3180	0.0318	0.0509	0.1474	0.4105	0.8081	0.0000	0.0000	0.0000
1997	0.0000	0.0127	0.0503	0.0428	0.1030	0.2044	0.3678	0.4384	0.2978	0.1336	0.3249	0.2935	0.9743	1.0181	0.0000	0.0000
1998	0.0000	0.0098	0.0710	0.1183	0.0715	0.1318	0.1828	0.2992	0.2943	0.3342	0.2328	0.0427	0.6777	0.9292	0.9292	0.0000
1999	0.0000	0.0010	0.0282	0.0449	0.0849	0.1058	0.1617	0.2416	0.3703	0.3918	0.1754	0.6678	0.1259	2.1803	0.0000	0.7111
2000	0.0000	0.0004	0.0273	0.1448	0.0533	0.0884	0.1302	0.1804	0.3355	0.4914	0.4756	0.2712	1.0069	0.7180	0.7180	0.7180
2001	0.0000	0.0001	0.0054	0.0635	0.1485	0.0735	0.0975	0.1260	0.1606	0.2545	0.2896	0.2690	0.0949	0.3055	0.0000	0.3055
2002	0.0000	0.0096	0.0157	0.0401	0.1292	0.1531	0.0706	0.1239	0.1505	0.1742	0.2551	0.3278	0.1976	0.2260	0.0000	0.5018
2003	0.0000	0.0009	0.0199	0.0306	0.0555	0.1167	0.1043	0.0674	0.1285	0.1678	0.2096	0.2460	0.4030	0.1854	0.2911	0.0000
2004	0.0001	0.0006	0.0070	0.0290	0.0491	0.0670	0.0951	0.1109	0.0999	0.1188	0.1807	0.2133	0.3742	0.5344	0.2700	0.2700
2005	0.0000	0.0013	0.0106	0.0324	0.0625	0.0901	0.1120	0.1338	0.1306	0.1723	0.2057	0.2183	0.2769	0.3892	0.3892	0.3892

Table 3.7.4.1. Norwegian spring spawning herring. Stock in numbers (billions).

7.	AGE																
YEAR	0	1	2	3	4	5	6	7	8	9	10	11	12	13	14	15	16
1950	750.680	26.465	14.278	10.874	4.023	4.978	8.612	8.004	1.965	2.804	3.203	2.583	5.632	6.148	0.952	2.567	6.709
1951	146.355	301.944	9.484	5.422	9.103	3.292	4.113	6.905	6.306	1.617	2.331	2.656	2.142	4.667	4.950	0.757	5.388
1952	96.644	58.461	117.910	3.601	4.661	7.479	2.673	3.387	5.465	4.869	1.321	1.930	2.190	1.744	3.782	3.938	3.488
1953	86.102	30.543	17.934	47.153	3.063	3.956	5.878	2.174	2.726	4.351	3.840	1.063	1.581	1.785	1.402	3.082	4.103
1954	42.086	31.374	9.195	6.921	39.898	2.593	3.311	4.730	1.795	2.243	3.453	2.939	0.858	1.277	1.449	1.115	3.831
1955	24.971	10.304	8.247	3.193	5.710	33.009	2.099	2.631	3.616	1.427	1.745	2.564	2.102	0.656	1.005	1.124	2.629
1956	29.859	6.852	2.358	3.028	2.662	4.658	26.514	1.701	2.089	2.857	1.149	1.323	1.932	1.621	0.510	0.787	1.905
1957	25.397	8.719	1.496	0.559	2.498	2.058	3.718	20.450	1.362	1.608	2.214	0.867	0.955	1.410	1.244	0.381	1.440
1958	23.094	7.136	1.447	0.468	0.460	1.804	1.628	2.988	15.760	1.105	1.266	1.737	0.665	0.709	1.075	0.948	0.959
1959	412.478	3.225	1.117	0.163	0.387	0.379	1.450	1.319	2.391	12.661	0.886	0.976	1.308	0.480	0.539	0.860	1.040
1960	197.514	156.290	1.185	0.247	0.127	0.308	0.302	1.112	1.029	1.835	9.874	0.680	0.725	0.942	0.331	0.392	1.057
1961	76.103	72.088	54.883	0.231	0.099	0.092	0.239	0.237	0.868	0.817	1.390	7.419	0.506	0.503	0.669	0.233	0.849
1962	19.003	26.983	19.058	20.474	0.170	0.078	0.075	0.192	0.186	0.690	0.658	1.070	5.710	0.390	0.391	0.517	0.589
1963	168.931	5.371	8.368	7.085	15.912	0.139	0.064	0.058	0.146	0.149	0.539	0.517	0.813	4.160	0.294	0.286	0.573
1964	93.903	65.617	0.833	2.098	5.392	12.920	0.115	0.054	0.047	0.109	0.120	0.364	0.359	0.538	2.724	0.180	0.295
1965	8.491	35.874	24.938	0.198	1.700	4.271	9.222	0.086	0.045	0.037	0.071	0.076	0.224	0.233	0.321	1.627	0.148
1966	51.409	1.984	12.175	8.320	0.087	1.225	3.146	5.897	0.056	0.025	0.025	0.043	0.028	0.100	0.100	0.148	0.719
1967	3.947	18.398	0.384	3.880	5.260	0.050	0.622	1.496	2.400	0.013	0.008	0.006	0.013	0.014	0.022	0.020	0.455
1968	5.187	1.333	1.182	0.111	2.048	1.509	0.018	0.144	0.238	0.469	0.003	0.002	0.002	0.003	0.004	0.003	0.276
1969	9.785	0.972	0.263	0.233	0.004	0.018	0.011	0.003	0.037	0.080	0.083	0.001	0.000	0.001	0.000	0.001	0.168
1970	0.661	3.620	0.072	0.017	0.026	0.003	0.007	0.005	0.002	0.021	0.038	0.038	0.000	0.000	0.000	0.000	0.101
1971	0.236	0.193	1.134	0.008	0.008	0.005	0.002	0.003	0.002	0.000	0.006	0.008	0.007	0.000	0.000	0.000	0.061
1972	0.957	0.077	0.051	0.407	0.005	0.006	0.003	0.001	0.002	0.000	0.000	0.001	0.001	0.001	0.000	0.000	0.037
1973	12.884	0.168	0.005	0.008	0.317	0.001	0.002	0.000	0.000	0.000	0.000	0.000	0.000	0.000	0.000	0.000	0.023
1974	8.631	5.220	0.066	0.001	0.004	0.250	0.000	0.000	0.000	0.000	0.000	0.000	0.000	0.000	0.000	0.000	0.014
1975	2.971	3.467	2.117	0.024	0.001	0.004	0.192	0.000	0.000	0.000	0.000	0.000	0.000	0.000	0.000	0.000	0.008
1976	10.068	1.188	1.407	0.860	0.018	0.000	0.002	0.137	0.000	0.000	0.000	0.000	0.000	0.000	0.000	0.000	0.005
1977	5.095	4.080	0.482	0.571	0.718	0.010	0.000	0.002	0.106	0.000	0.000	0.000	0.000	0.000	0.000	0.000	0.003
1978	6.201	2.044	1.655	0.194	0.471	0.596	0.009	0.000	0.001	0.081	0.000	0.000	0.000	0.000	0.000	0.000	0.002
1979	12.498	2.508	0.830	0.672	0.164	0.394	0.494	0.007	0.000	0.001	0.065	0.000	0.000	0.000	0.000	0.000	0.001
1980	1.474	5.060	1.017	0.336	0.573	0.139	0.333	0.415	0.005	0.000	0.000	0.054	0.000	0.000	0.000	0.000	0.001
1981	1.100	0.595	2.057	0.413	0.283	0.487	0.118	0.279	0.343	0.004	0.000	0.000	0.044	0.000	0.000	0.000	0.000

Table 3.7.4.1. cont. Norwegian spring spawning herring. Stock in numbers (billions).

YEAR	AGE																
	0	1	2	3	4	5	6	7	8	9	10	11	12	13	14	15	16
1982	2.343	0.442	0.241	0.829	0.352	0.240	0.412	0.099	0.236	0.287	0.003	0.000	0.000	0.037	0.000	0.000	0.000
1983	343.398	0.938	0.179	0.098	0.700	0.296	0.202	0.348	0.084	0.198	0.242	0.003	0.000	0.000	0.032	0.000	0.000
1984	11.528	139.534	0.378	0.072	0.081	0.583	0.246	0.168	0.294	0.071	0.167	0.201	0.002	0.000	0.000	0.026	0.000
1985	36.608	4.665	56.729	0.152	0.058	0.065	0.445	0.194	0.133	0.238	0.054	0.128	0.167	0.002	0.000	0.000	0.014
1986	6.042	14.866	1.888	22.932	0.111	0.035	0.041	0.262	0.113	0.063	0.147	0.037	0.082	0.097	0.002	0.000	0.007
1987	9.090	2.448	6.043	0.766	19.237	0.079	0.017	0.021	0.128	0.027	0.016	0.055	0.014	0.009	0.010	0.001	0.004
1988	30.204	3.687	0.991	2.434	0.641	16.093	0.051	0.011	0.011	0.085	0.012	0.005	0.043	0.005	0.002	0.002	0.003
1989	74.349	12.270	1.497	0.397	2.037	0.528	13.340	0.035	0.006	0.004	0.059	0.002	0.001	0.034	0.002	0.000	0.003
1990	121.734	30.224	4.987	0.593	0.339	1.750	0.449	11.181	0.027	0.005	0.003	0.048	0.001	0.001	0.029	0.001	0.002
1991	341.838	49.493	12.288	2.018	0.493	0.289	1.495	0.377	9.414	0.022	0.003	0.001	0.039	0.000	0.000	0.024	0.002
1992	406.020	138.981	20.120	4.994	1.729	0.422	0.248	1.273	0.316	7.900	0.017	0.002	0.000	0.033	0.000	0.000	0.016
1993	121.213	165.074	56.505	8.179	4.286	1.457	0.358	0.212	1.085	0.267	6.590	0.012	0.001	0.000	0.027	0.000	0.010
1994	42.863	49.277	67.114	22.969	7.014	3.590	1.173	0.300	0.179	0.906	0.212	5.291	0.010	0.001	0.000	0.023	0.006
1995	15.667	17.427	20.035	27.281	19.739	5.935	2.753	0.857	0.244	0.147	0.745	0.150	3.956	0.006	0.000	0.000	0.017
1996	70.204	6.370	7.085	8.145	23.428	16.668	4.530	1.777	0.523	0.196	0.112	0.577	0.051	2.559	0.002	0.000	0.011
1997	47.279	28.543	2.590	2.861	6.978	19.503	12.889	3.027	1.153	0.354	0.163	0.089	0.435	0.028	1.426	0.001	0.006
1998	305.200	19.222	11.605	1.039	2.342	5.755	15.120	9.244	1.899	0.689	0.249	0.122	0.047	0.290	0.006	0.884	0.005
1999	241.941	124.085	7.815	4.665	0.829	1.791	4.612	11.381	6.784	1.280	0.473	0.175	0.081	0.037	0.146	0.000	0.489
2000	68.362	98.366	50.449	3.174	3.888	0.680	1.416	3.571	8.307	4.759	0.832	0.309	0.137	0.033	0.025	0.043	0.244
2001	47.910	27.794	39.993	20.502	2.654	2.826	0.553	1.116	2.698	5.944	3.127	0.515	0.199	0.103	0.007	0.000	0.157
2002	358.142	19.479	11.300	16.258	17.551	2.135	2.037	0.440	0.872	2.047	4.338	2.221	0.375	0.149	0.085	0.003	0.088
2003	207.606	145.610	7.920	4.555	13.810	14.510	1.601	1.450	0.351	0.664	1.517	3.118	1.596	0.273	0.117	0.067	0.055
2004	593.763	84.407	59.198	3.217	3.851	11.586	11.811	1.215	1.092	0.281	0.502	1.104	2.158	1.171	0.199	0.093	0.071
2005	1.092	241.406	34.316	24.040	2.746	3.229	9.573	9.503	0.943	0.812	0.217	0.383	0.793	1.485	0.812	0.146	0.095
2006	0.000	0.444	98.148	13.939	20.288	2.276	2.628	7.652	7.307	0.700	0.584	0.154	0.269	0.549	0.952	0.579	0.169

Table 3.7.4.2. Norwegian spring spawning herring. Fishing mortality.

YEAR	AGE																
	0	1	2	3	4	5	6	7	8	9	10	11	12	13	14	15	16
1950	0.011	0.126	0.068	0.028	0.051	0.041	0.071	0.088	0.045	0.035	0.038	0.037	0.038	0.067	0.078	0.046	0.046
1951	0.018	0.040	0.068	0.001	0.047	0.058	0.044	0.084	0.109	0.053	0.039	0.043	0.056	0.060	0.079	0.070	0.070
1952	0.252	0.282	0.017	0.012	0.014	0.091	0.057	0.067	0.078	0.087	0.067	0.049	0.054	0.068	0.055	0.073	0.073
1953	0.110	0.301	0.052	0.017	0.017	0.028	0.067	0.041	0.045	0.081	0.117	0.065	0.064	0.058	0.079	0.078	0.078
1954	0.507	0.436	0.158	0.042	0.040	0.061	0.080	0.118	0.080	0.101	0.148	0.185	0.118	0.089	0.104	0.130	0.130
1955	0.393	0.575	0.102	0.032	0.054	0.069	0.060	0.081	0.085	0.067	0.127	0.133	0.110	0.101	0.095	0.104	0.104
1956	0.331	0.622	0.540	0.042	0.107	0.075	0.110	0.072	0.111	0.105	0.131	0.176	0.165	0.115	0.143	0.130	0.130
1957	0.369	0.896	0.262	0.046	0.176	0.084	0.069	0.111	0.059	0.089	0.093	0.116	0.147	0.121	0.121	0.100	0.100
1958	1.069	0.954	1.282	0.041	0.043	0.069	0.061	0.073	0.069	0.071	0.111	0.133	0.174	0.125	0.074	0.082	0.082
1959	0.070	0.102	0.611	0.105	0.078	0.077	0.115	0.099	0.115	0.099	0.114	0.148	0.178	0.221	0.168	0.113	0.113
1960	0.108	0.147	0.733	0.759	0.168	0.104	0.091	0.098	0.080	0.128	0.136	0.145	0.214	0.193	0.204	0.139	0.139
1961	0.137	0.430	0.086	0.157	0.092	0.049	0.070	0.092	0.080	0.067	0.112	0.112	0.112	0.101	0.107	0.106	0.106
1962	0.364	0.271	0.090	0.102	0.052	0.044	0.109	0.121	0.071	0.097	0.090	0.125	0.167	0.130	0.163	0.147	0.147
1963	0.046	0.964	0.483	0.123	0.058	0.042	0.031	0.069	0.145	0.069	0.243	0.214	0.263	0.274	0.344	0.257	0.257
1964	0.062	0.067	0.536	0.061	0.083	0.187	0.138	0.031	0.072	0.283	0.306	0.333	0.284	0.366	0.365	0.320	0.320
1965	0.554	0.181	0.198	0.672	0.177	0.156	0.297	0.280	0.444	0.239	0.344	0.838	0.659	0.691	0.627	0.620	0.620
1966	0.128	0.742	0.244	0.308	0.405	0.529	0.593	0.749	1.307	0.976	1.343	1.064	0.543	1.370	1.484	1.188	1.188
1967	0.186	1.845	0.339	0.489	1.099	0.853	1.311	1.690	1.483	1.328	1.451	1.082	1.257	1.131	1.992	1.478	1.478
1968	0.775	0.722	0.724	3.232	4.591	4.749	1.812	1.214	0.936	1.577	1.288	1.320	0.771	1.964	1.245	1.362	1.362
1969	0.094	1.707	1.867	2.046	0.259	0.756	0.599	0.347	0.419	0.600	0.626	0.612	0.867	0.394	0.843	0.578	0.578
1970	0.333	0.261	1.297	0.529	1.486	0.298	0.678	1.105	1.164	1.178	1.368	1.555	3.941	1.618	0.823	1.406	1.406
1971	0.226	0.429	0.125	0.283	0.140	0.308	0.277	0.476	1.626	2.550	1.958	2.279	1.841	0.217	2.804	2.028	2.028
1972	0.842	1.834	0.987	0.098	1.293	0.956	1.819	1.252	2.980	1.779	0.039	1.571	2.069	1.110	0.332	2.106	2.106
1973	0.004	0.033	0.769	0.405	0.089	0.857	1.521	1.117	1.365	0.015	0.029	0.047	0.009	0.014	1.264	0.603	0.603
1974	0.012	0.002	0.097	0.122	0.060	0.112	0.973	0.779	0.009	0.019	0.017	0.035	0.058	0.011	0.016	0.017	0.017
1975	0.016	0.002	0.001	0.157	0.222	0.319	0.189	0.038	0.014	0.010	0.023	0.021	0.042	0.072	0.012	0.019	0.019
1976	0.003	0.003	0.001	0.030	0.397	0.002	0.000	0.109	0.009	0.008	0.012	0.027	0.024	0.052	0.090	0.015	0.015
1977	0.013	0.002	0.010	0.043	0.036	0.036	0.003	0.266	0.116	0.011	0.010	0.014	0.033	0.029	0.064	0.116	0.116
1978	0.005	0.002	0.001	0.017	0.028	0.037	0.115	0.003	0.743	0.069	0.012	0.011	0.017	0.039	0.035	0.079	0.079
1979	0.004	0.002	0.004	0.010	0.012	0.019	0.025	0.055	0.003	0.002	0.043	0.015	0.013	0.020	0.048	0.042	0.042
1980	0.007	0.000	0.001	0.021	0.011	0.018	0.027	0.042	0.093	0.033	0.002	0.055	0.017	0.016	0.023	0.058	0.058
1981	0.012	0.003	0.009	0.011	0.018	0.019	0.020	0.018	0.026	0.092	0.692	0.384	0.024	0.020	0.019	0.028	0.028

Table 3.7.4.2. cont. Norwegian spring spawning herring. Fishing mortality.

YEAR	AGE																
	0	1	2	3	4	5	6	7	8	9	10	11	12	13	14	15	16
1982	0.015	0.004	0.001	0.018	0.024	0.020	0.017	0.021	0.023	0.023	0.040	0.539	0.194	0.004	0.024	0.022	0.022
1983	0.001	0.008	0.015	0.036	0.033	0.035	0.034	0.021	0.017	0.025	0.033	0.058	2.280	3.311	0.030	0.029	0.029
1984	0.005	0.000	0.010	0.070	0.074	0.121	0.083	0.084	0.059	0.116	0.112	0.035	0.000	0.294	0.242	0.070	0.070
1985	0.001	0.004	0.006	0.165	0.343	0.320	0.378	0.396	0.590	0.336	0.221	0.302	0.389	0.001	0.506	0.379	0.379
1986	0.004	0.000	0.003	0.026	0.187	0.588	0.530	0.565	1.264	1.250	0.835	0.820	2.057	2.161	0.001	1.396	1.396
1987	0.002	0.004	0.009	0.028	0.028	0.293	0.254	0.461	0.268	0.639	1.062	0.093	0.903	1.516	1.516	0.417	0.417
1988	0.001	0.001	0.015	0.028	0.043	0.038	0.223	0.436	0.857	0.206	1.464	1.056	0.088	0.875	4.757	0.381	0.381
1989	0.000	0.000	0.027	0.008	0.002	0.012	0.027	0.113	0.149	0.198	0.062	0.912	0.744	0.010	0.171	0.090	0.090
1990	0.000	0.000	0.005	0.034	0.008	0.007	0.026	0.022	0.053	0.436	1.430	0.056	1.678	0.413	0.022	0.153	0.153
1991	0.000	0.000	0.000	0.005	0.006	0.005	0.011	0.026	0.025	0.130	0.214	0.172	0.019	1.646	1.990	0.024	0.024
1992	0.000	0.000	0.000	0.003	0.021	0.013	0.005	0.010	0.020	0.031	0.175	0.486	0.963	0.041	0.048	0.029	0.029
1993	0.000	0.000	0.000	0.004	0.027	0.067	0.026	0.019	0.030	0.078	0.069	0.000	0.001	0.008	0.000	0.059	0.059
1994	0.000	0.000	0.000	0.002	0.017	0.116	0.164	0.058	0.050	0.045	0.200	0.141	0.349	0.939	2.220	0.100	0.100
1995	0.000	0.000	0.000	0.002	0.019	0.120	0.287	0.343	0.071	0.124	0.106	0.924	0.286	1.200	4.053	0.100	0.100
1996	0.000	0.000	0.007	0.005	0.033	0.107	0.253	0.283	0.240	0.032	0.074	0.132	0.463	0.435	0.001	0.303	0.303
1997	0.000	0.000	0.013	0.050	0.043	0.105	0.182	0.316	0.364	0.205	0.142	0.497	0.254	1.365	0.328	0.262	0.262
1998	0.000	0.000	0.011	0.076	0.118	0.071	0.134	0.159	0.244	0.227	0.204	0.254	0.084	0.541	6.411	0.142	0.142
1999	0.000	0.000	0.001	0.032	0.048	0.085	0.106	0.165	0.205	0.281	0.277	0.094	0.756	0.236	1.067	0.133	0.133
2000	0.000	0.000	0.000	0.029	0.169	0.057	0.088	0.130	0.185	0.270	0.330	0.288	0.137	1.364	7.710	0.125	0.125
2001	0.000	0.000	0.000	0.005	0.067	0.178	0.079	0.097	0.126	0.165	0.192	0.168	0.137	0.038	0.693	0.117	0.117
2002	0.000	0.000	0.009	0.013	0.040	0.138	0.190	0.076	0.123	0.150	0.180	0.180	0.165	0.094	0.093	0.109	0.109
2003	0.000	0.000	0.001	0.018	0.026	0.056	0.126	0.133	0.073	0.129	0.168	0.218	0.160	0.165	0.078	0.101	0.101
2004	0.000	0.000	0.001	0.008	0.026	0.041	0.067	0.104	0.146	0.108	0.120	0.181	0.224	0.215	0.164	0.093	0.093
2005	0.000	0.000	0.001	0.020	0.038	0.056	0.074	0.112	0.148	0.180	0.192	0.205	0.217	0.293	0.188	0.085	0.085

Table 3.7.4.3. Norwegian spring spawning herring. Stock summary table.

	RECRUITMENT	TOTAL BIOMASS	SPAWNING STOCK BIOMASS	LANDINGS	WEIGHTED F
YEAR	AGE 0	MILLION TONS	MILLION TONS	TONS	5-14
1950	750.68	20.013	14.653	826100	0.058
1951	146.355	19.274	12.913	1277900	0.07
1952	96.644	20.182	11.29	1254800	0.073
1953	86.102	17.419	9.671	1074400	0.066
1954	42.086	18.565	8.937	1644500	0.113
1955	24.971	15.725	9.556	1359800	0.078
1956	29.858	13.799	11.234	1659400	0.11
1957	25.397	11.088	9.913	1318500	0.103
1958	23.094	9.549	8.939	986300	0.079
1959	412.478	8.076	7.392	1111100	0.113
1960	197.514	7.634	6.022	1101800	0.136
1961	76.103	7.796	4.515	830100	0.104
1962	19.003	6.765	3.547	848600	0.146
1963	168.931	6.913	2.746	984500	0.253
1964	93.903	6.446	2.597	1281800	0.226
1965	8.491	5.935	3.164	1547700	0.278
1966	51.409	4.392	2.887	1955000	0.696
1967	3.947	3.018	1.515	1677200	1.519
1968	5.187	0.982	0.356	712200	3.493
1969	9.785	0.19	0.151	67800	0.59
1970	0.661	0.116	0.075	62300	1.32
1971	0.236	0.13	0.034	21100	1.525
1972	0.957	0.085	0.017	13161	1.497
1973	12.884	0.112	0.088	7017	1.173
1974	8.631	0.16	0.094	7619	0.114
1975	2.971	0.302	0.082	13713	0.19
1976	10.068	0.362	0.142	10436	0.106
1977	5.095	0.429	0.294	22706	0.111
1978	6.201	0.579	0.367	19824	0.043
1979	12.498	0.635	0.398	12864	0.024
1980	1.474	0.748	0.483	18577	0.034
1981	1.1	0.796	0.517	13736	0.022
1982	2.343	0.729	0.516	16655	0.02
1983	343.398	1.107	0.589	23054	0.029
1984	11.528	2.095	0.617	53532	0.09
1985	36.608	5.463	0.529	169872	0.379
1986	6.042	1.897	0.448	225256	1.074
1987	9.09	3.305	0.95	127306	0.404
1988	30.204	3.707	2.98	135301	0.042

Table 3.7.4.3. cont. Norwegian spring spawning herring. Stock summary table.

	RECRUITMENT	TOTAL BIOMASS	SPAWNING STOCK BIOMASS	LANDINGS	WEIGHTED F
YEAR	AGE 0	MILLION TONS	MILLION TONS	TONS	5-14
1989	74.349	4.351	3.627	103830	0.027
1990	121.734	4.883	3.785	86411	0.021
1991	341.838	5.582	3.943	84683	0.023
1992	406.02	6.704	3.811	104448	0.027
1993	121.213	7.897	3.706	232457	0.062
1994	42.863	9.079	4.236	479228	0.126
1995	15.667	10.025	5.215	905501	0.216
1996	70.204	10.189	6.959	1220283	0.177
1997	47.279	10.262	8.446	1426507	0.167
1998	305.2	9.181	7.822	1223131	0.144
1999	241.941	10.636	7.362	1235433	0.173
2000	68.362	9.888	6.041	1207201	0.203
2001	47.91	8.785	5.301	766136	0.158
2002	358.142	9.42	5.455	807795	0.163
2003	207.606	11.369	6.981	750077	0.102
2004	593.763	13.605	7.923	793666	0.084
2005	1.092	15.306	8.513	1003243	0.112

Table 3.9.1.1. Norwegian Spring-spawning herring. Input to short-term prediction.

2006								
Age	Stock size	Natural mortality	Maturity ogive	Prop. of F bef. spaw.	Prop. of M bef. spaw.	Weight in stock	Exploit. pattern	Weight in catch
1	31000	0.9	0.00	0.1	0.1	0.010	0.000	0.073
2	51700	0.9	0.00	0.1	0.1	0.042	0.010	0.105
3	5124	0.15	0.00	0.1	0.1	0.107	0.147	0.176
4	21479	0.15	0.90	0.1	0.1	0.149	0.295	0.226
5	2404	0.15	0.90	0.1	0.1	0.232	0.507	0.261
6	2774	0.15	1.00	0.1	0.1	0.272	0.903	0.290
7	8076	0.15	1.00	0.1	0.1	0.297	1.192	0.318
8	7548	0.15	1.00	0.1	0.1	0.318	1.268	0.341
9	718	0.15	1.00	0.1	0.1	0.371	1.392	0.363
10	608	0.15	1.00	0.1	0.1	0.365	1.609	0.375
11	160	0.15	1.00	0.1	0.1	0.393	2.059	0.374
12	278	0.15	1.00	0.1	0.1	0.395	2.070	0.380
13	566	0.15	1.00	0.1	0.1	0.399	2.244	0.392
14	997	0.15	1.00	0.1	0.1	0.415	1.421	0.402
15	610	0.15	1.00	0.1	0.1	0.442	0.915	0.420
16	185	0.5	1.00	0.1	0.1	0.434	0.915	0.439

2007								
Age	Stock size	Natural mortality	Maturity ogive	Prop. of F bef. spaw.	Prop. of M bef. spaw.	Weight in stock	Exploit. pattern	Weight in catch
1	31000	0.9	0.00	0.1	0.1	0.010	0.000	0.073
2		0.9	0.00	0.1	0.1	0.042	0.010	0.105
3		0.15	0.00	0.1	0.1	0.107	0.147	0.176
4		0.15	0.30	0.1	0.1	0.149	0.295	0.226
5		0.15	1.00	0.1	0.1	0.232	0.507	0.261
6		0.15	1.00	0.1	0.1	0.272	0.903	0.290
7		0.15	1.00	0.1	0.1	0.297	1.192	0.318
8		0.15	1.00	0.1	0.1	0.318	1.268	0.341
9		0.15	1.00	0.1	0.1	0.371	1.392	0.363
10		0.15	1.00	0.1	0.1	0.365	1.609	0.375
11		0.15	1.00	0.1	0.1	0.393	2.059	0.374
12		0.15	1.00	0.1	0.1	0.395	2.070	0.380
13		0.15	1.00	0.1	0.1	0.399	2.244	0.392
14		0.15	1.00	0.1	0.1	0.415	1.421	0.402
15		0.15	1.00	0.1	0.1	0.442	0.915	0.420
16		0.5	1.00	0.1	0.1	0.434	0.915	0.439

2008								
Age	Stock size	Natural mortality	Maturity ogive	Prop. of F bef. spaw.	Prop. of M bef. spaw.	Weight in stock	Exploit. pattern	Weight in catch
1	31000	0.9	0.00	0.1	0.1	0.010	0.000	0.073
2		0.9	0.00	0.1	0.1	0.042	0.010	0.105
3		0.15	0.00	0.1	0.1	0.107	0.147	0.176
4		0.15	0.30	0.1	0.1	0.149	0.295	0.226
5		0.15	0.90	0.1	0.1	0.232	0.507	0.261
6		0.15	1.00	0.1	0.1	0.272	0.903	0.290
7		0.15	1.00	0.1	0.1	0.297	1.192	0.318
8		0.15	1.00	0.1	0.1	0.318	1.268	0.341
9		0.15	1.00	0.1	0.1	0.371	1.392	0.363
10		0.15	1.00	0.1	0.1	0.365	1.609	0.375
11		0.15	1.00	0.1	0.1	0.393	2.059	0.374
12		0.15	1.00	0.1	0.1	0.395	2.070	0.380
13		0.15	1.00	0.1	0.1	0.399	2.244	0.392
14		0.15	1.00	0.1	0.1	0.415	1.421	0.402
15		0.15	1.00	0.1	0.1	0.442	0.915	0.420
16		0.5	1.00	0.1	0.1	0.434	0.915	0.439

Table 3.9.1.2. Norwegian spring spawning herring. Short term prediction.

2006					2007					2008	
Biomass	SSB	FMult	FBar	Landings	Biomass	SSB	FMult	FBar	Landings	Biomass	SSB
13992	10330	0.735	0.096	967	14393	10685	0.0	0.000	0	14918	11377
.	10674	0.1	0.010	110	14814	11278
.	10663	0.2	0.020	219	14712	11180
.	10653	0.3	0.030	326	14611	11083
.	10642	0.4	0.040	433	14510	10988
.	10632	0.5	0.051	538	14411	10893
.	10622	0.6	0.061	642	14313	10800
.	10611	0.7	0.071	746	14216	10708
.	10601	0.8	0.081	848	14120	10616
.	10590	0.9	0.091	949	14025	10526
.	10580	1.0	0.101	1049	13932	10437
.	10569	1.1	0.111	1147	13839	10348
.	10559	1.2	0.121	1245	13747	10261
.	10555	1.24	0.125	1280	13714	10230
.	10549	1.3	0.132	1342	13656	10174
.	10538	1.4	0.142	1438	13566	10089
.	10530	1.48	0.150	1514	13495	10021
.	10518	1.6	0.162	1627	13390	9921
.	10507	1.7	0.172	1720	13303	9838
.	10497	1.8	0.182	1811	13217	9757
.	10487	1.9	0.192	1902	13131	9676
.	10476	2.0	0.202	1993	13047	9596

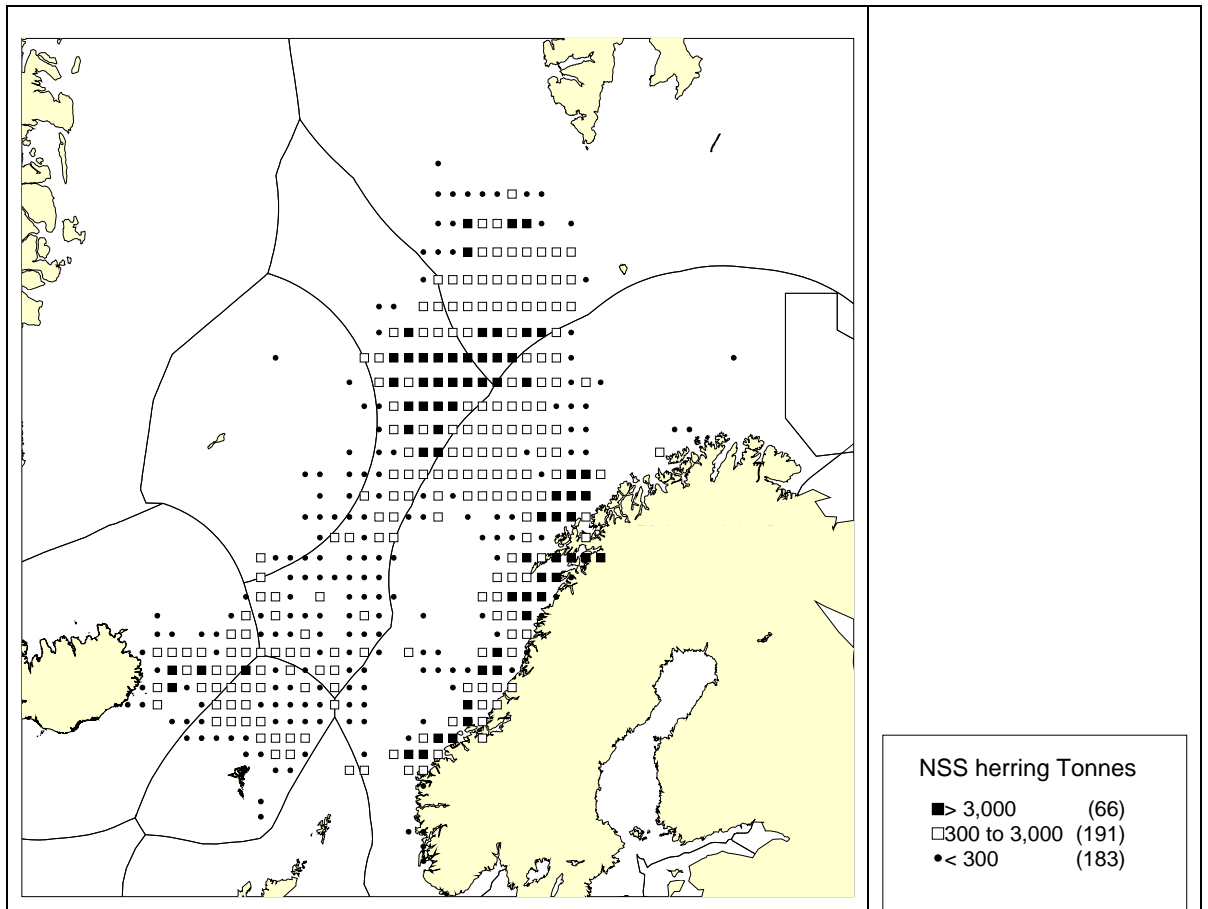
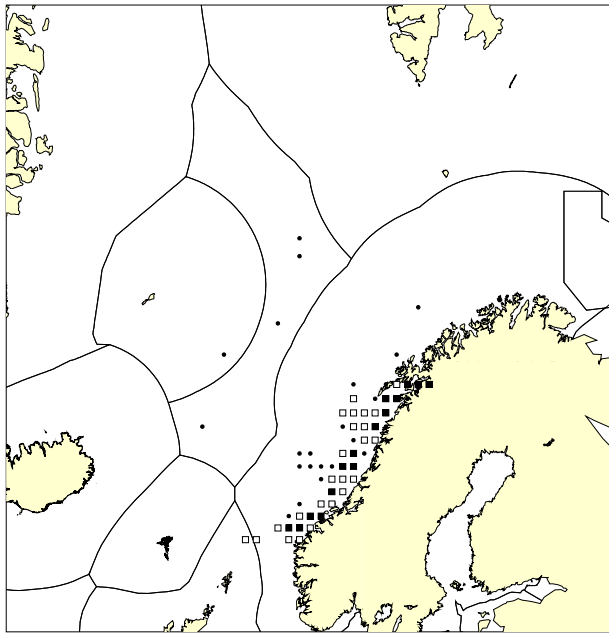
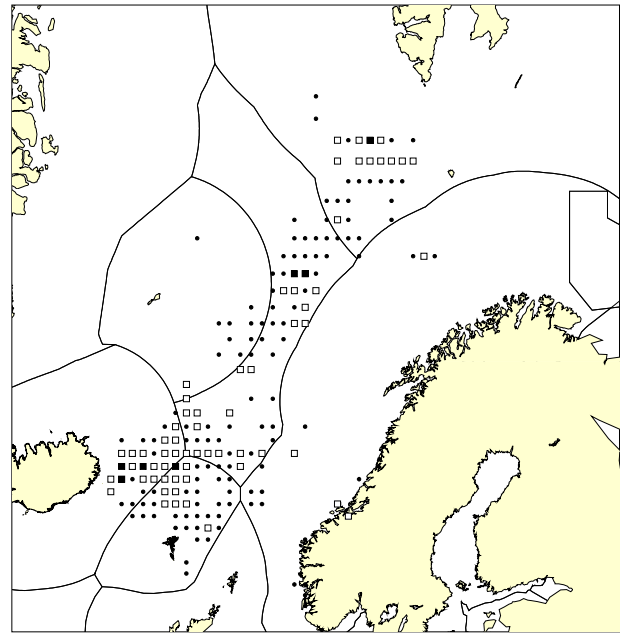

Figure 3.3.1. Total reported catches of Norwegian spring-spawning herring in 2005 by ICES rectangle. Grading of the symbols: black dots less than 300 t, open squares 300-3 000 t, and black squares > 3 000 t.



Quarter 1



Quarter 2

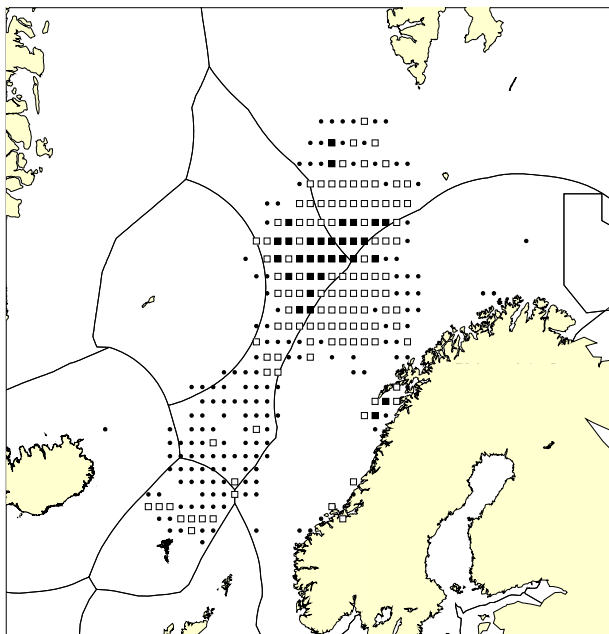

Quarter 3

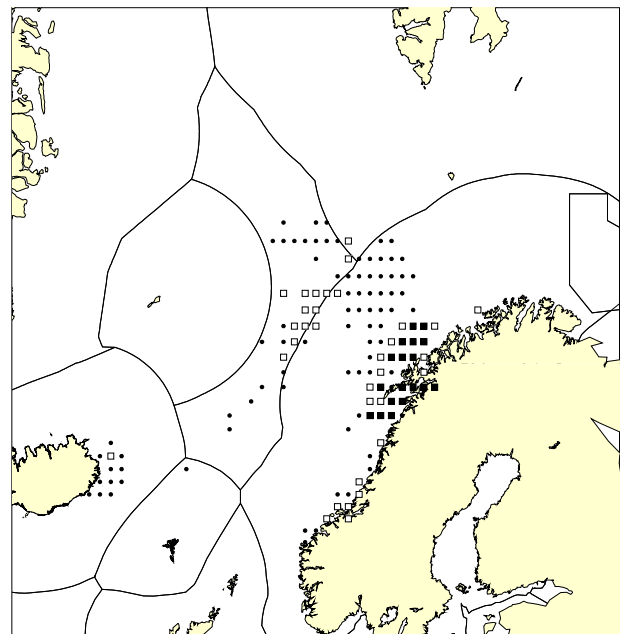

Quarter 4

Figure 3.3.2. Total reported catches of Norwegian spring-spawning herring in 2005 by quarter and ICES rectangle. Grading of the symbols: black dots less than 300 t, open squares 300-3 000 t, and black squares > 3 000 t. Some catches reported in the northern part of the North Sea in first quarter are considered to be of autumn-spawning origin.

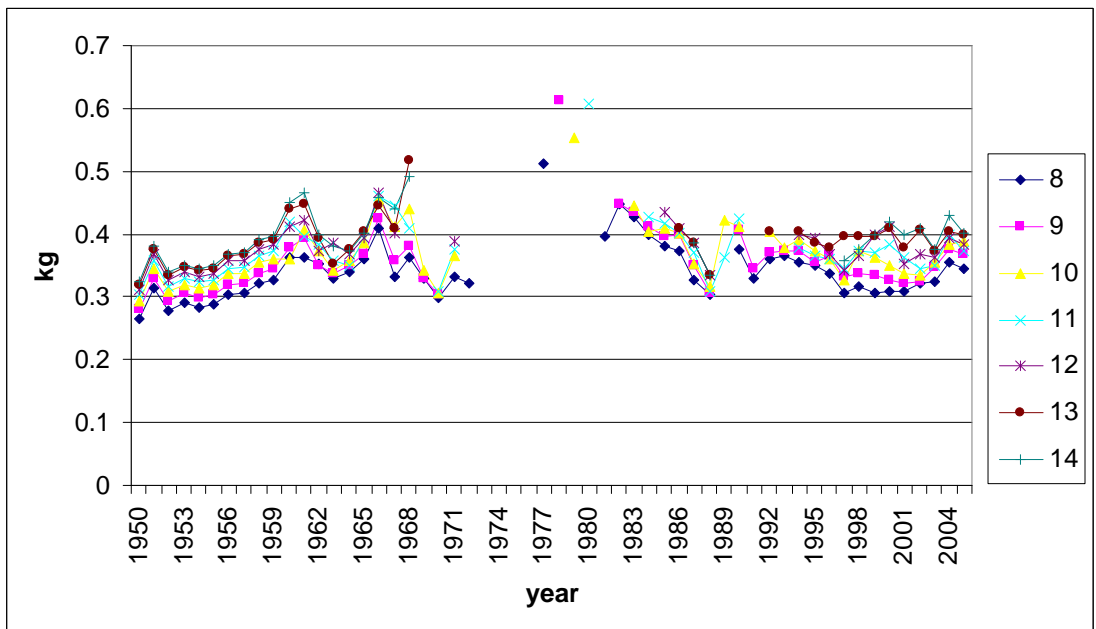
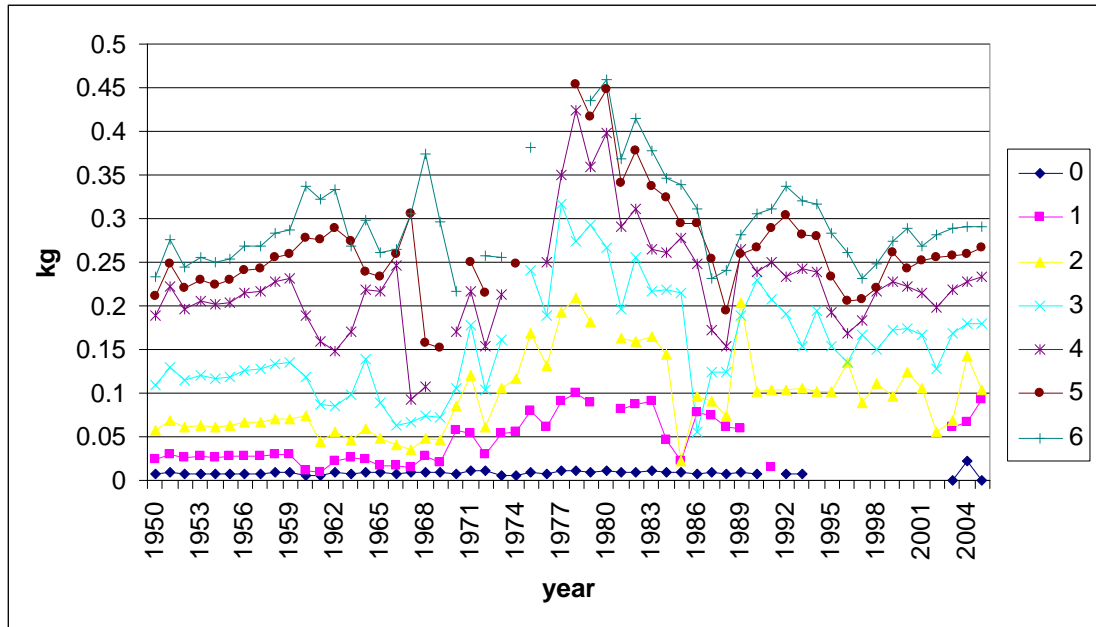

Figure 3.5.5.1. NSSH: Trends in weight at age in the catch by age group (weight at age for zero catch numbers were omitted)

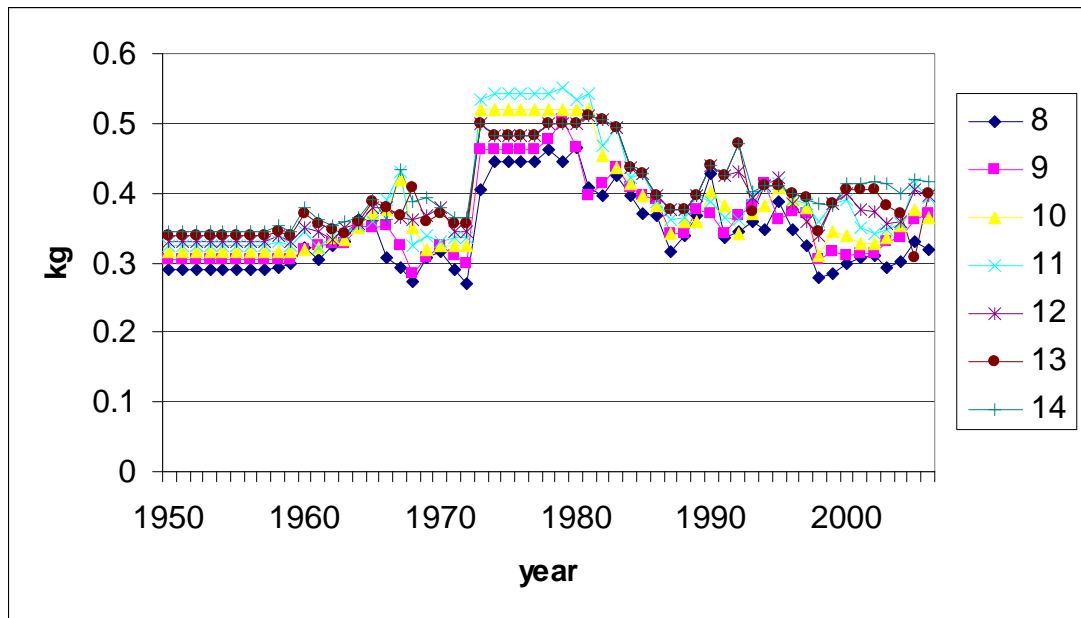
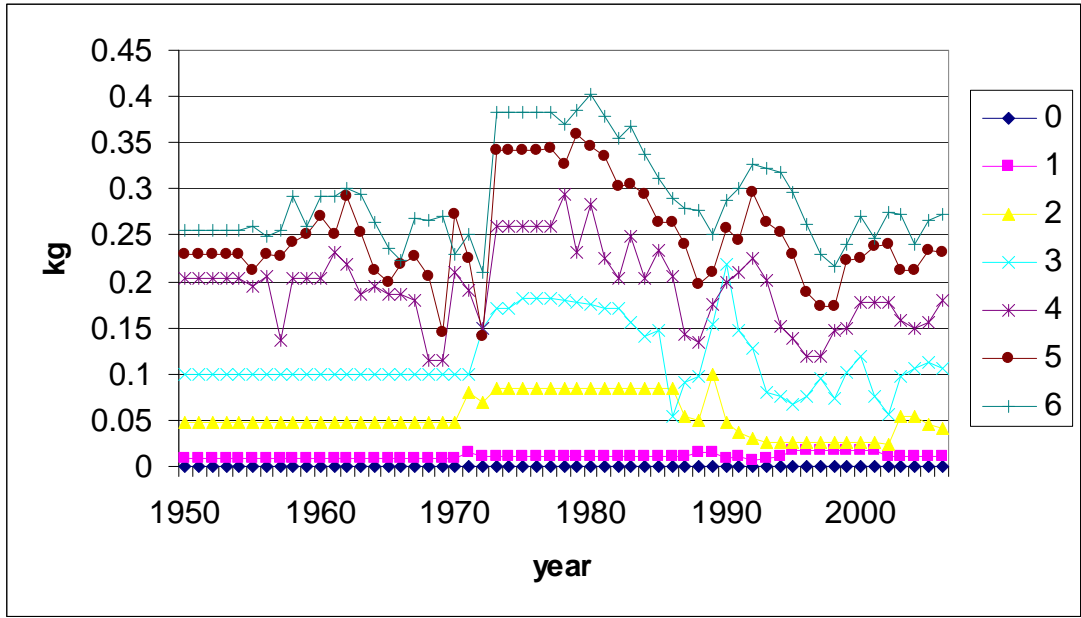

Figure 3.5.5.2. NSSH: Trends in weight at age in the stock by age group

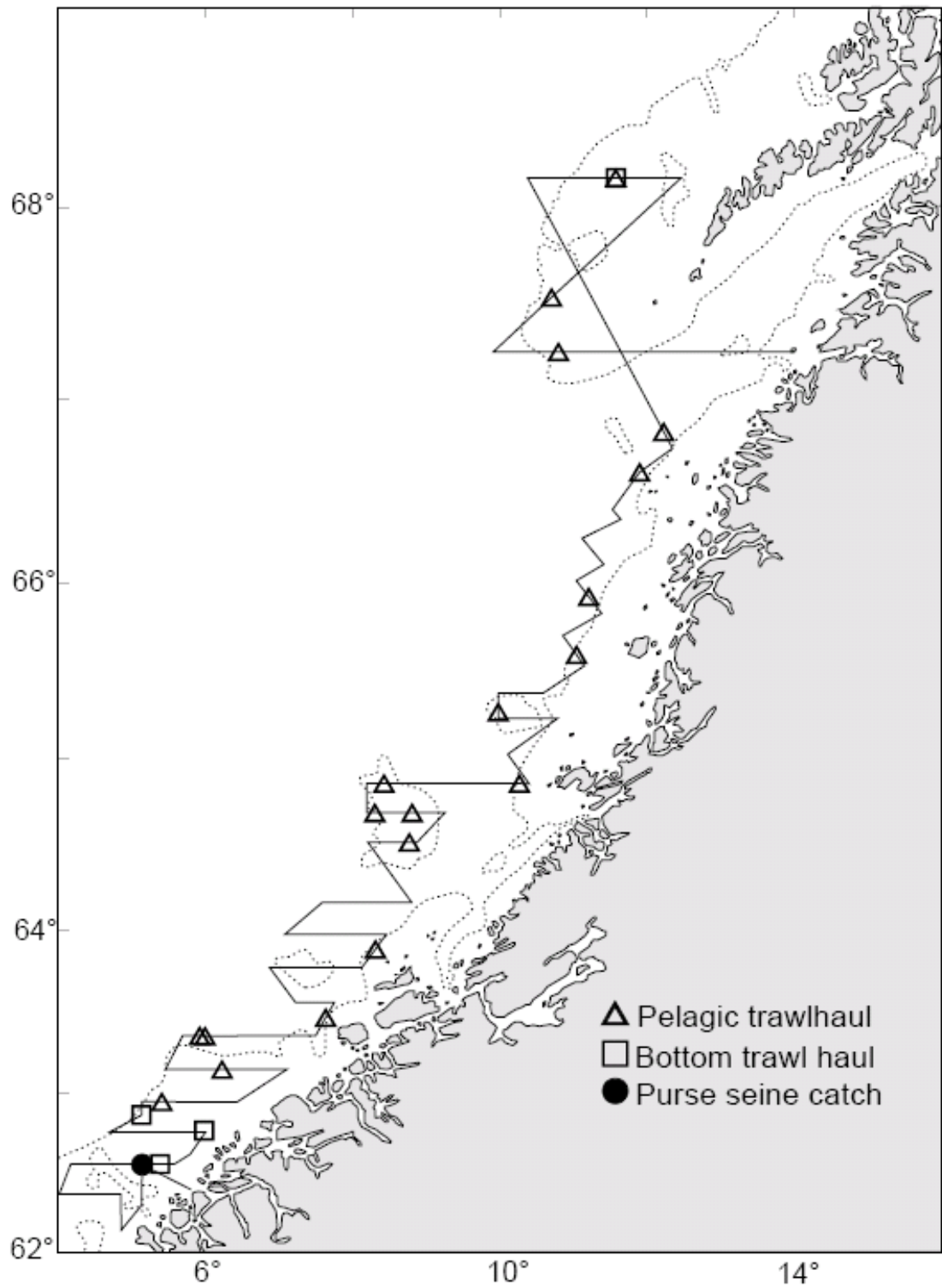

Figure 3.6.1.1.1. NSSH Acoustic survey on spawning grounds in February March

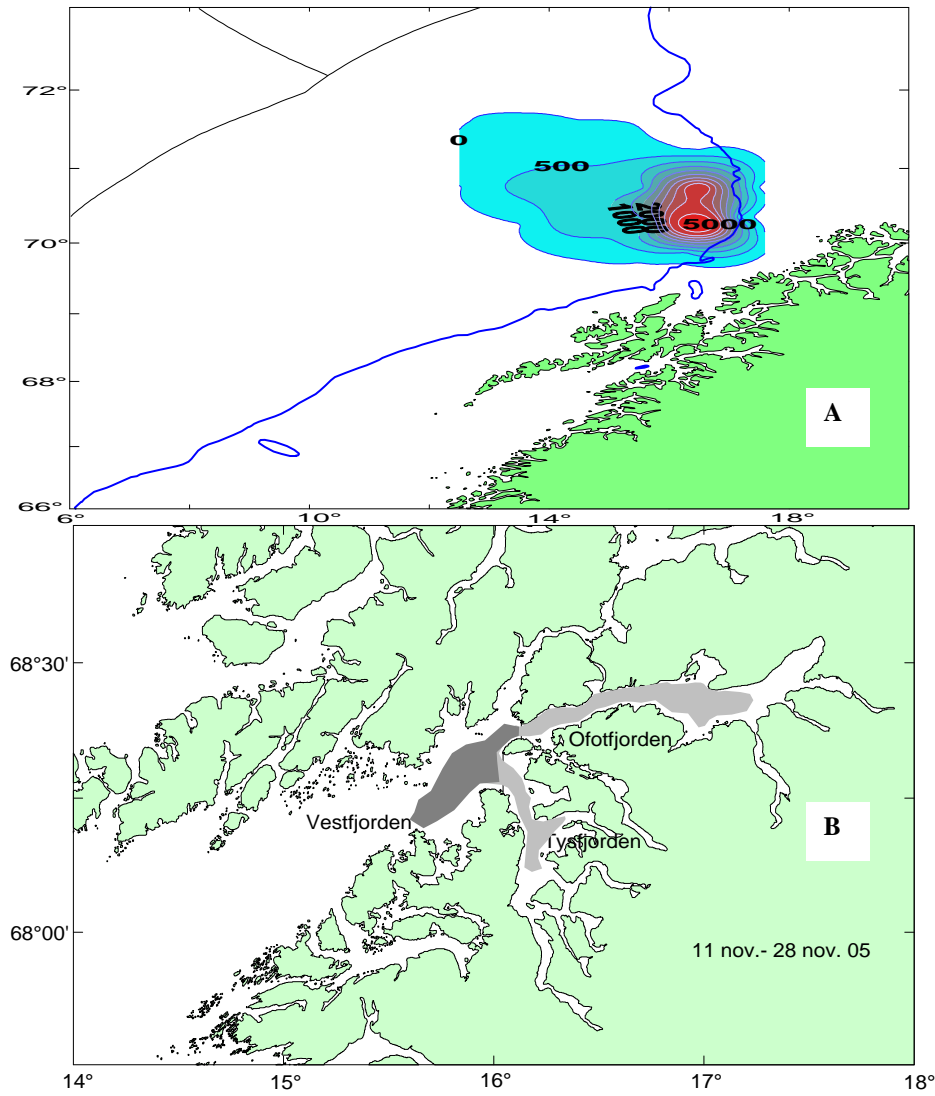

Figure 3.6.1.2.1. NSSH Acoustic survey in November/December

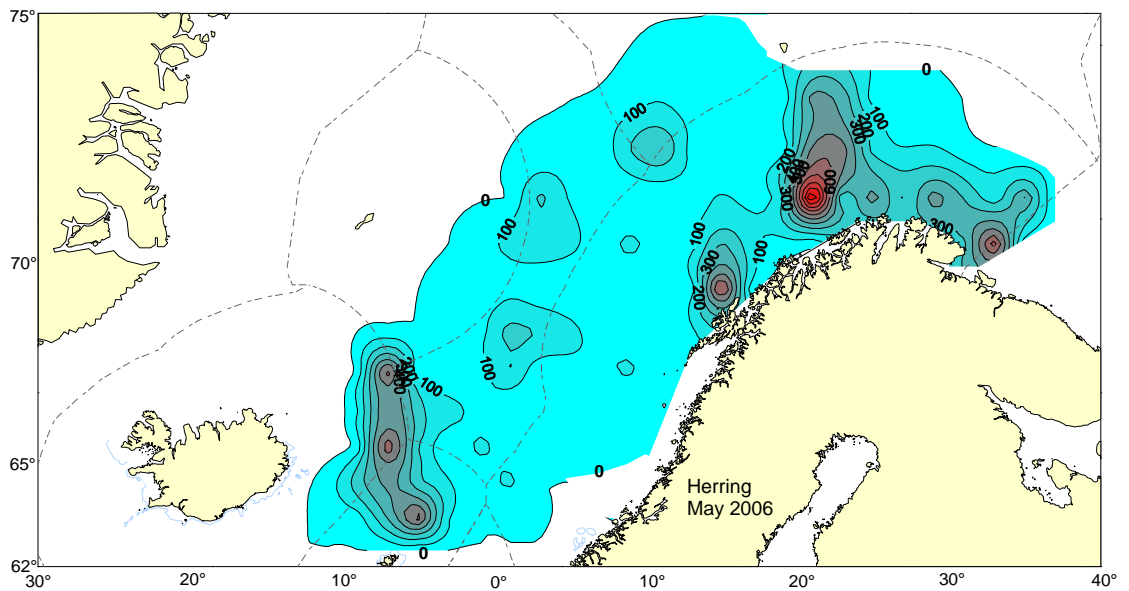

Figure 3.6.1.3.1. NSSH Acoustic surveys in May in the Norwegian Sea and Barents Sea

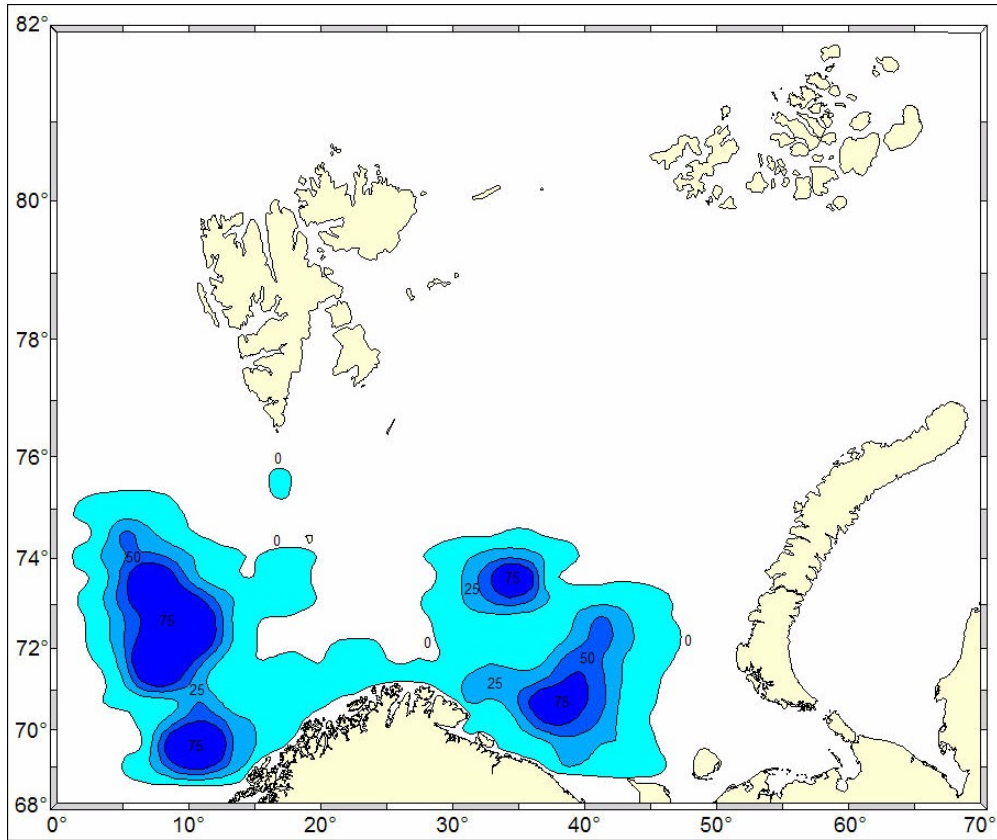

Figure 3.6.1.4.1. NSSH Acoustic surveys in August/September in the Barents Sea

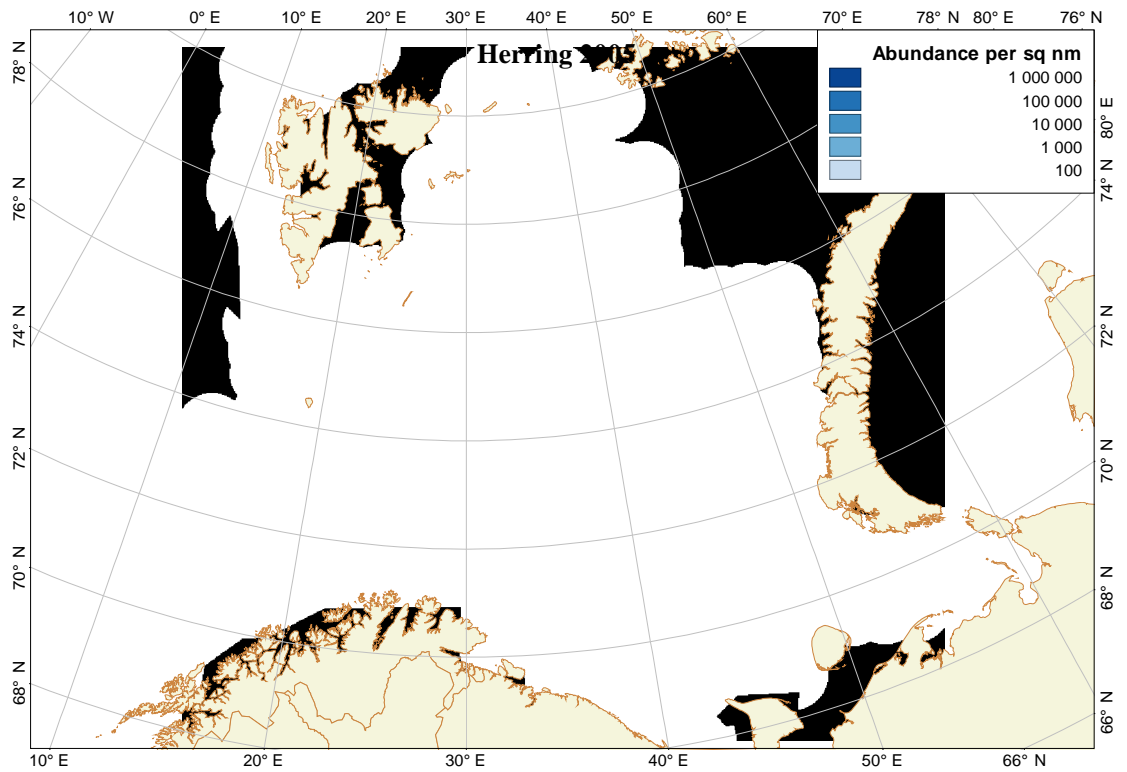

Figure 3.6.1.4.2. NSSH O-group surveys in August/September in the Barents Sea

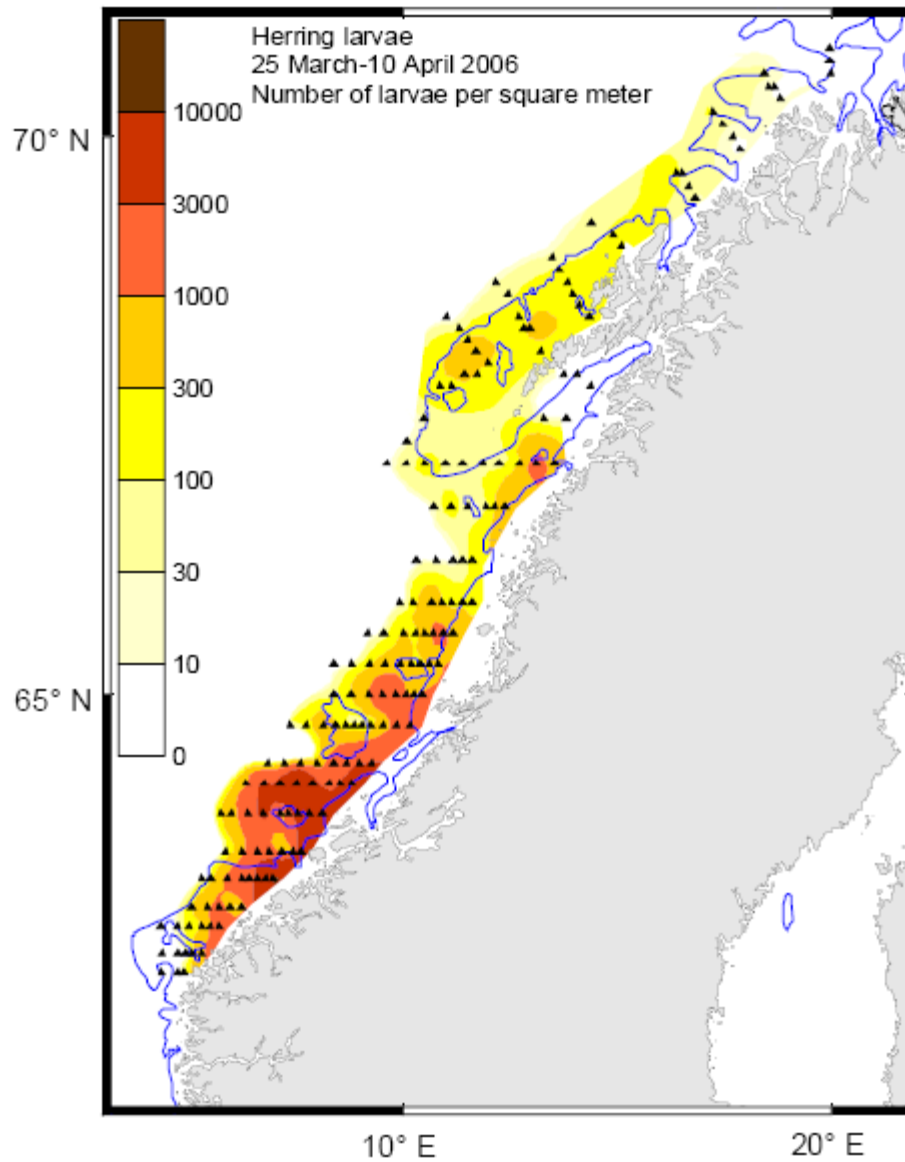

Figure 3.6.1.5.1 NSSH. Distribution of herring larvae on the Norwegian shelf. The 200 m isobath is also shown.

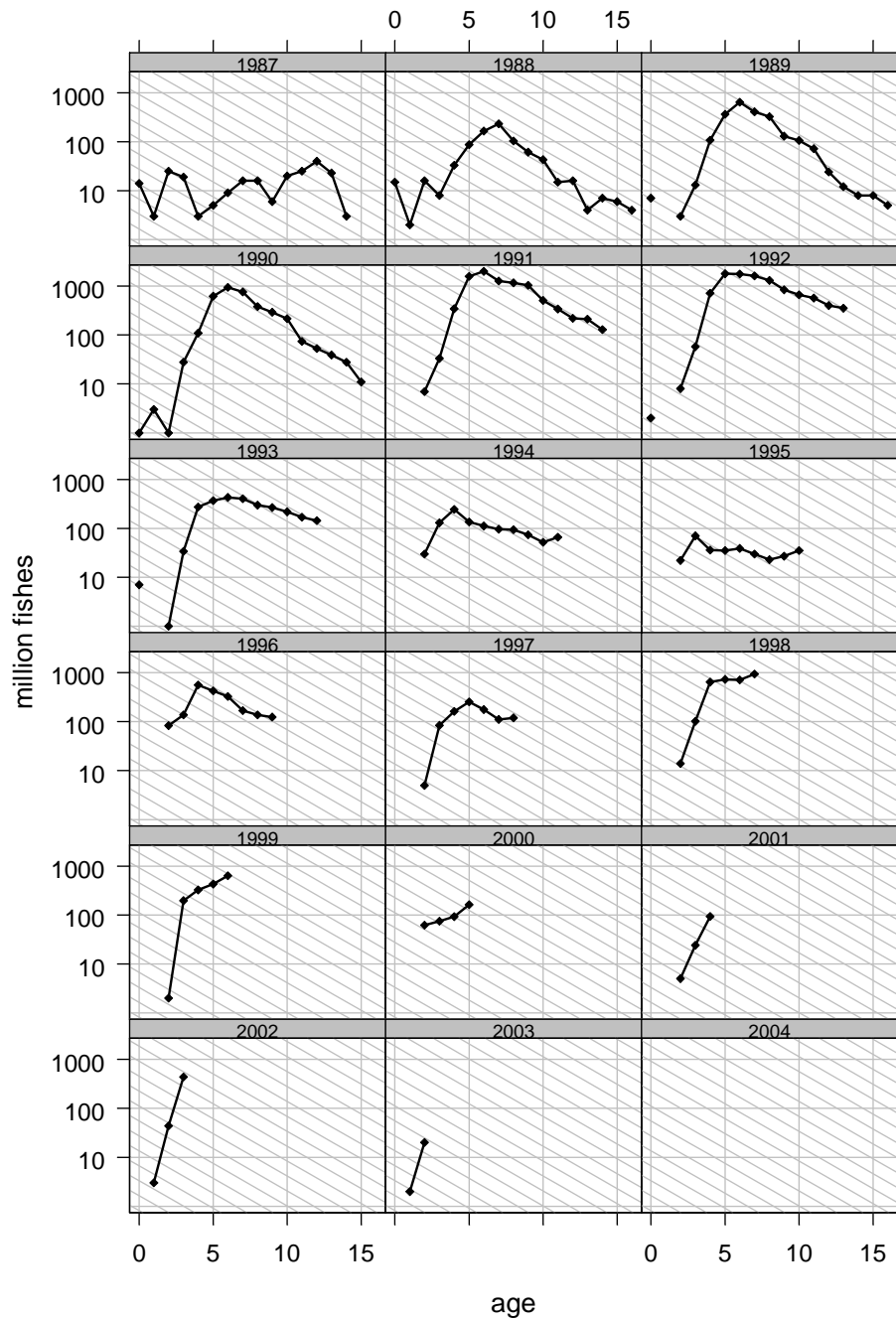

Figure 3.7.1.1. Norwegian spring spawning herring. Age disaggregated catch in numbers plotted on a log scale. The labels above each figure indicate yearclasses. The grey lines correspond to $Z=0.4$.

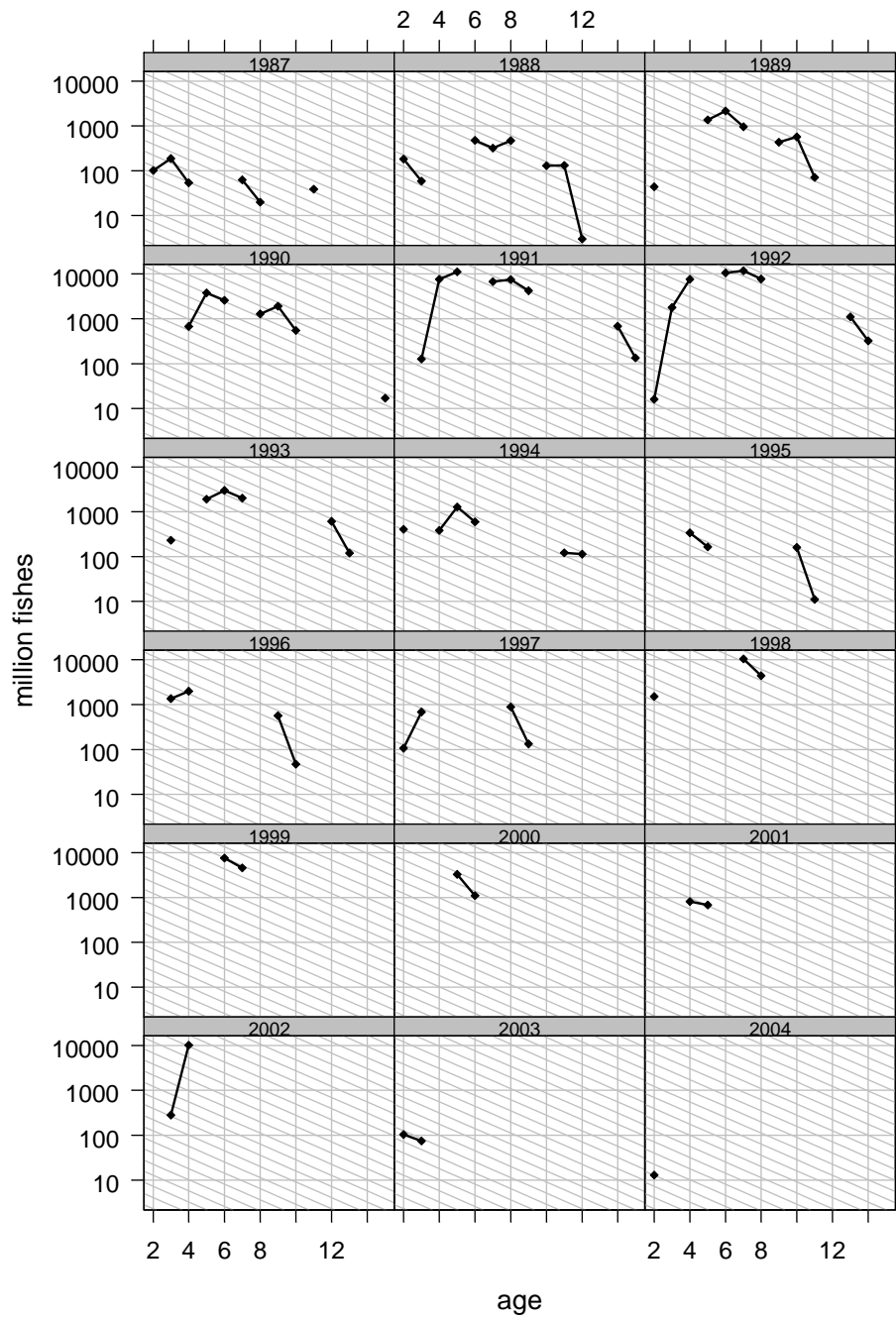

Figure 3.7.1.2. Norwegian spring spawning herring. Age disaggregated abundance indices from the acoustic surveys on the spawning stock in February-March plotted on log scale. The labels above each figure indicate yearclasses. The grey lines correspond to $Z=0.4$.

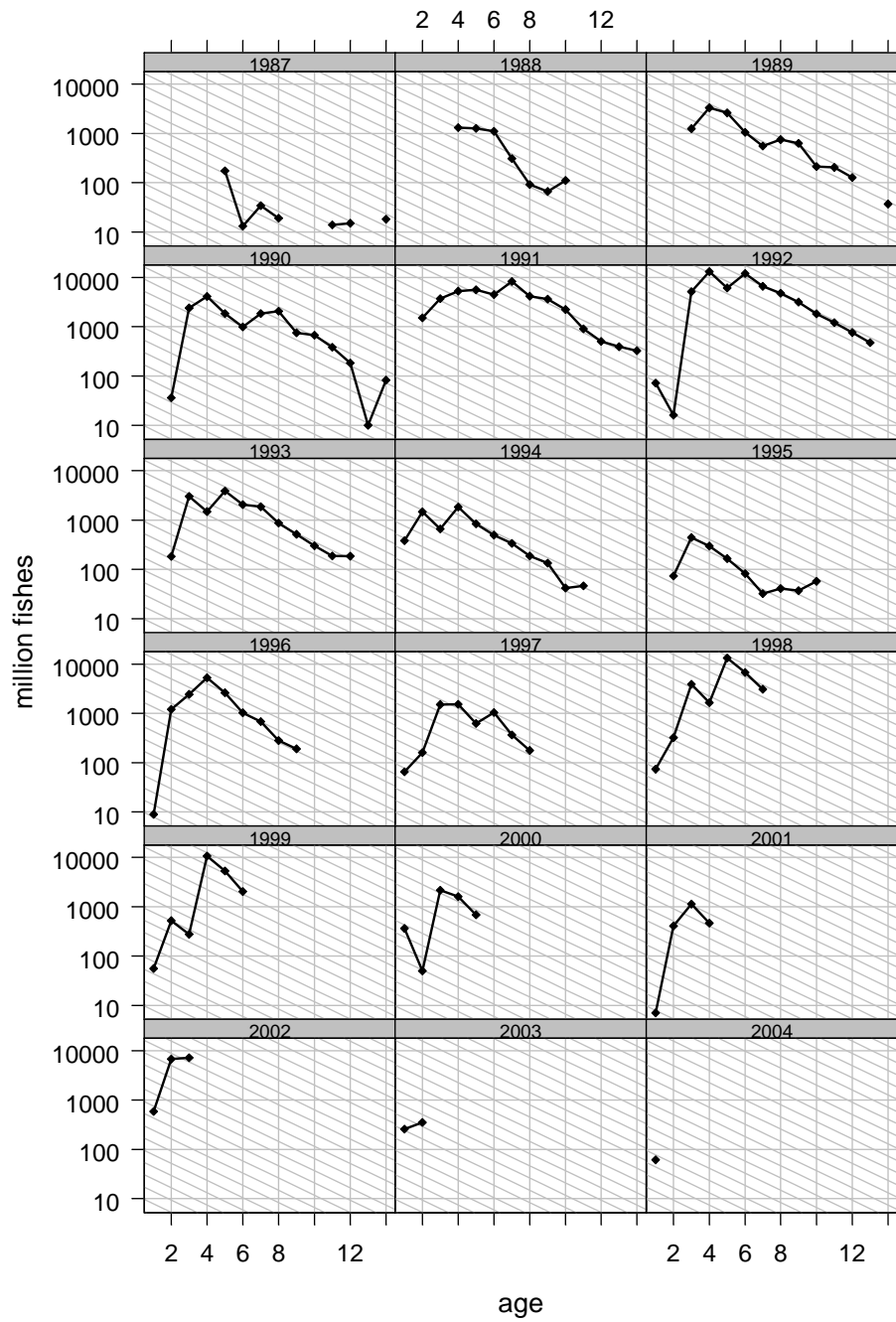

Figure 3.7.1.3. Norwegian spring spawning herring. Age disaggregated abundance indices from the acoustic surveys in the wintering areas in November-December plotted on log scale. The labels above each figure indicate yearclasses. The grey lines correspond to $Z=0.4$.

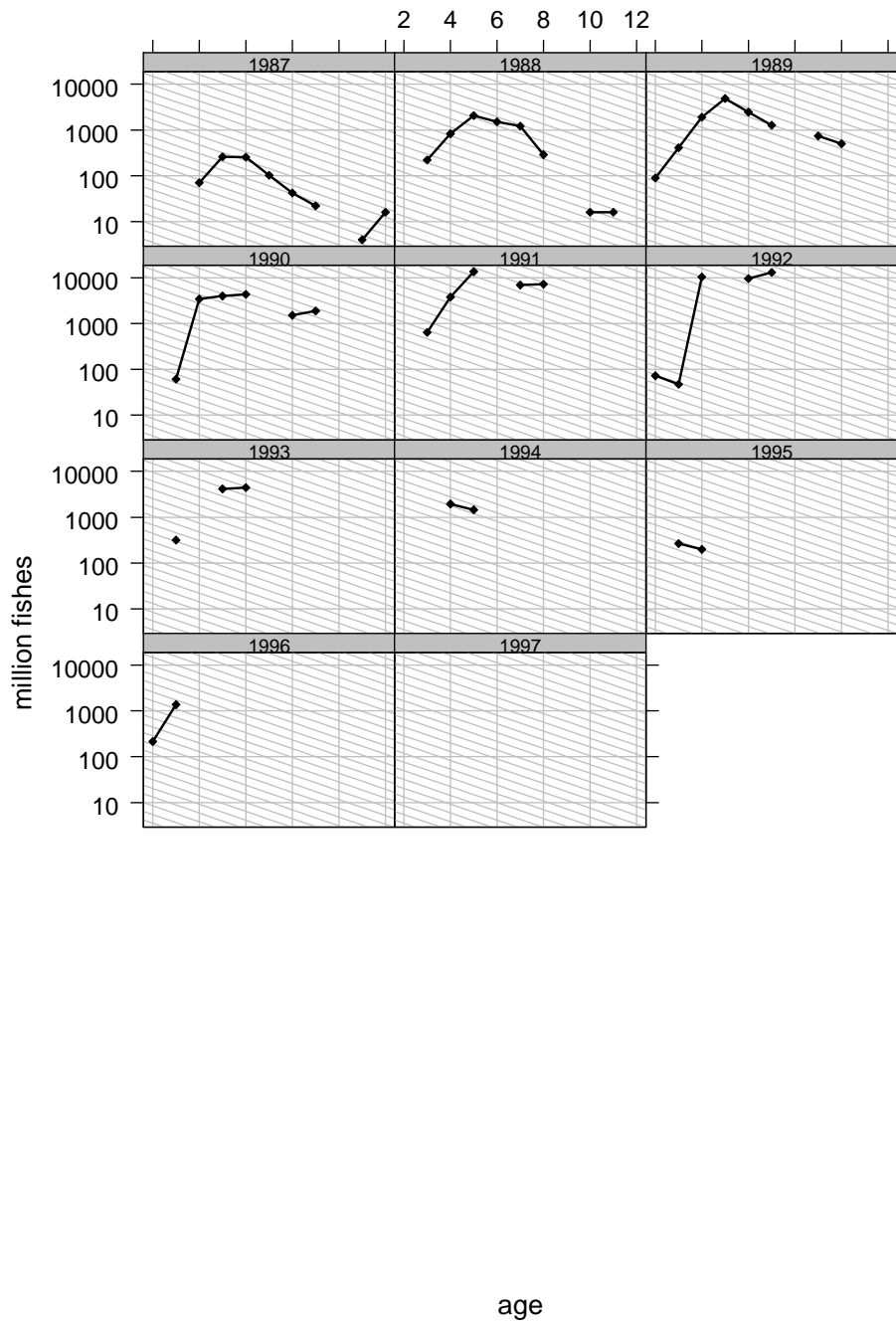

Figure 3.7.1.4. Norwegian spring spawning herring. Age disaggregated abundance indices from the acoustic surveys in the wintering areas in January plotted on log scale. The labels above each figure indicate yearclasses. The grey lines correspond to $Z=0.4$.

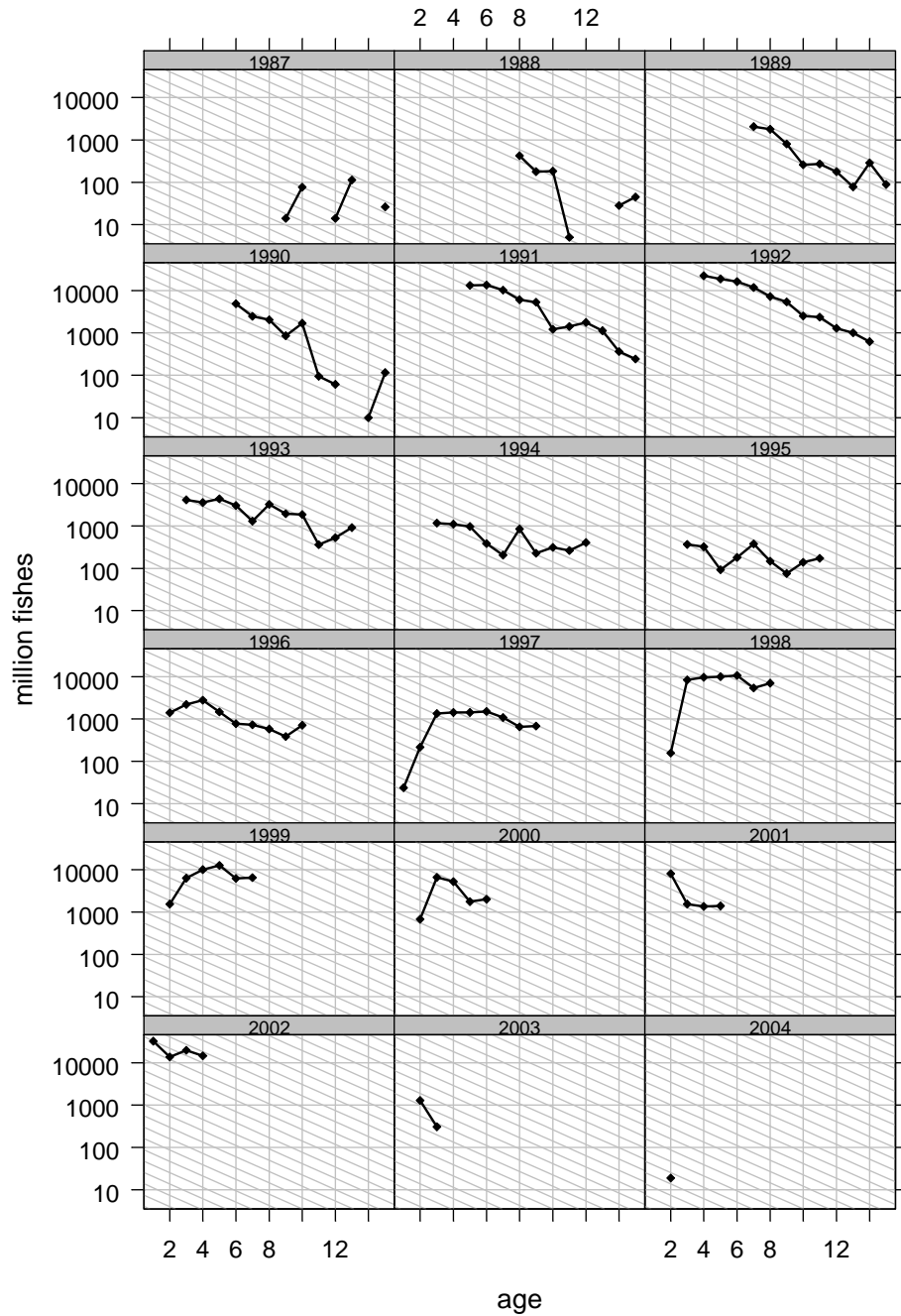

Figure 3.7.1.5. Norwegian spring spawning herring. Age disaggregated abundance indices from the acoustic surveys on the feeding areas in the Norwegian Sea in May plotted on log scale. The labels above each figure indicate yearclasses. The grey lines correspond to $Z=0.4$.

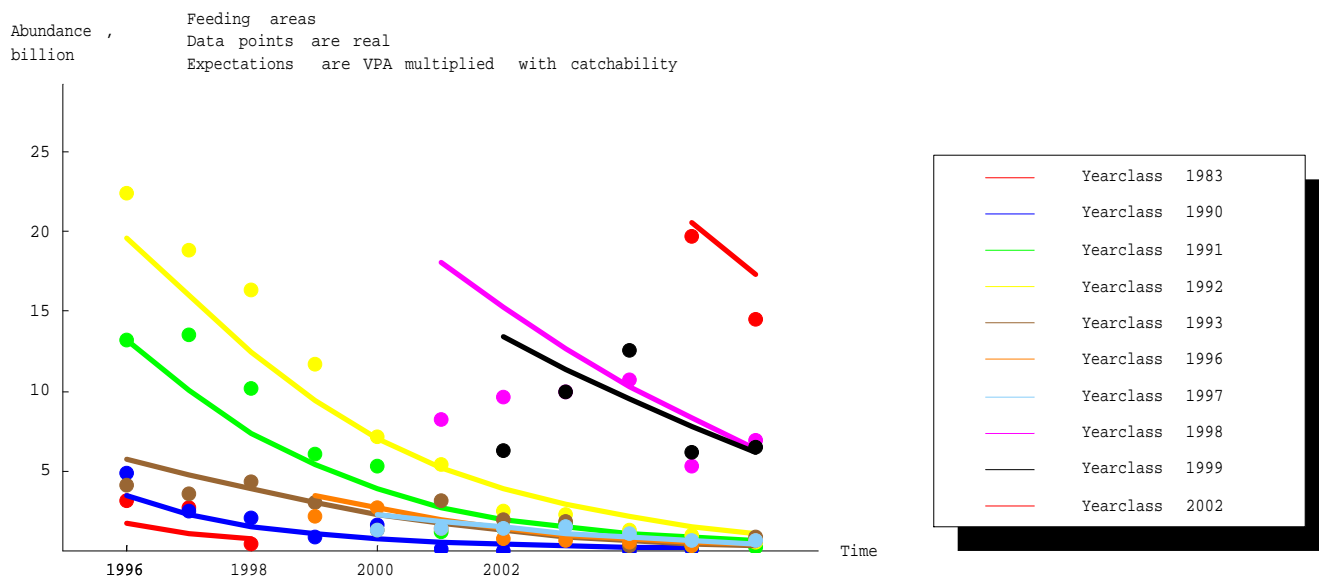
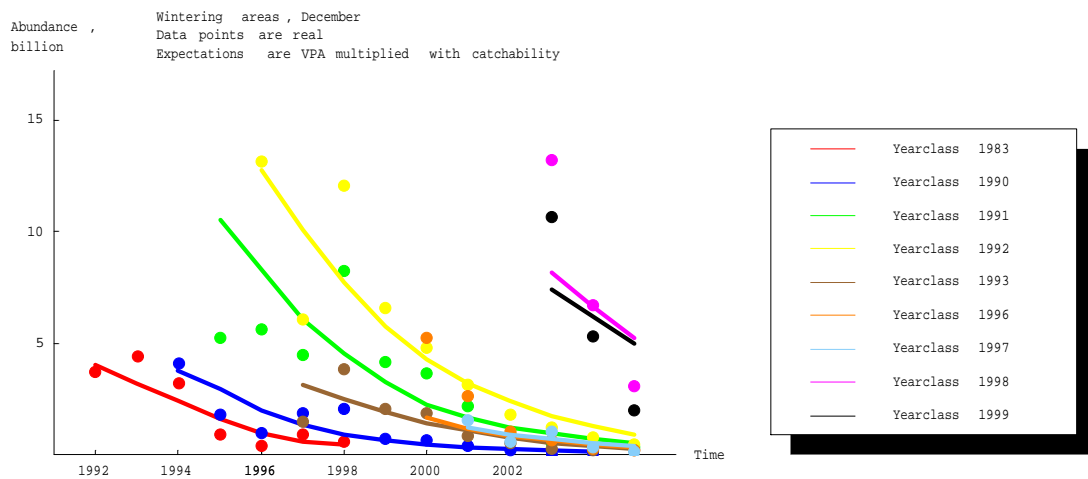
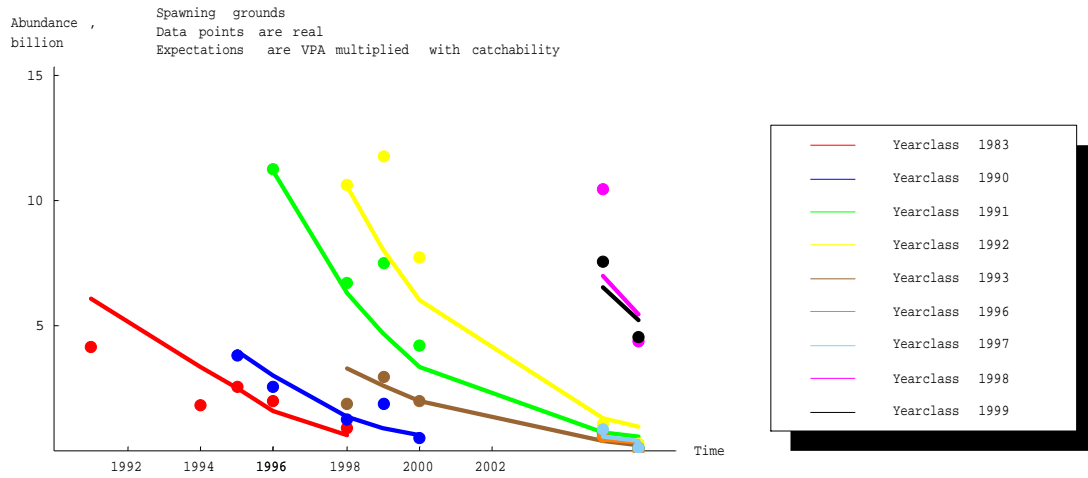

Figure 3.7.2.1.1. NSSH Survey data and historic abundance scaled with catchability when settings are the same as in 2005 for SeaStar, for surveys 1 ,2, 5.

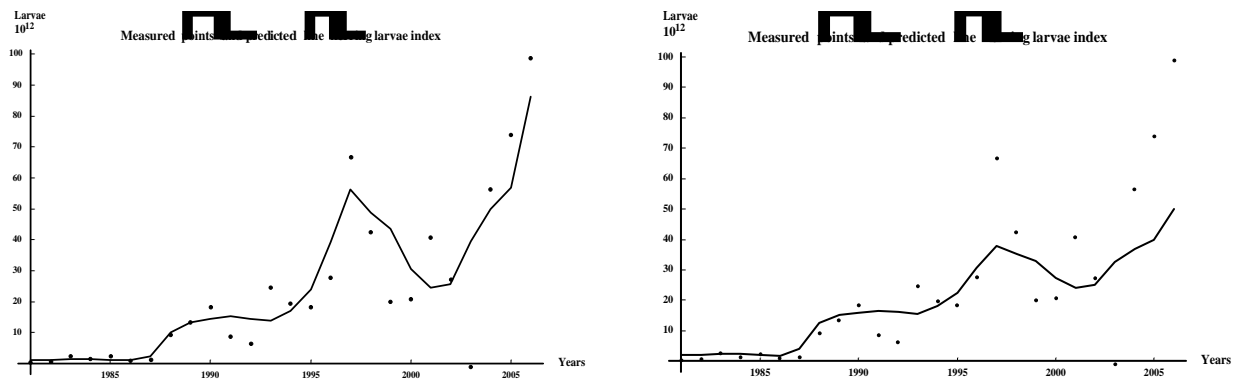

Figure 3.7.2.1.2. NSSH. The observed larval index (dots) and expectation value (solid line) with (left) and without (right) using the amended larval observation model. The deleted 2003 point is marked below the X-axis.

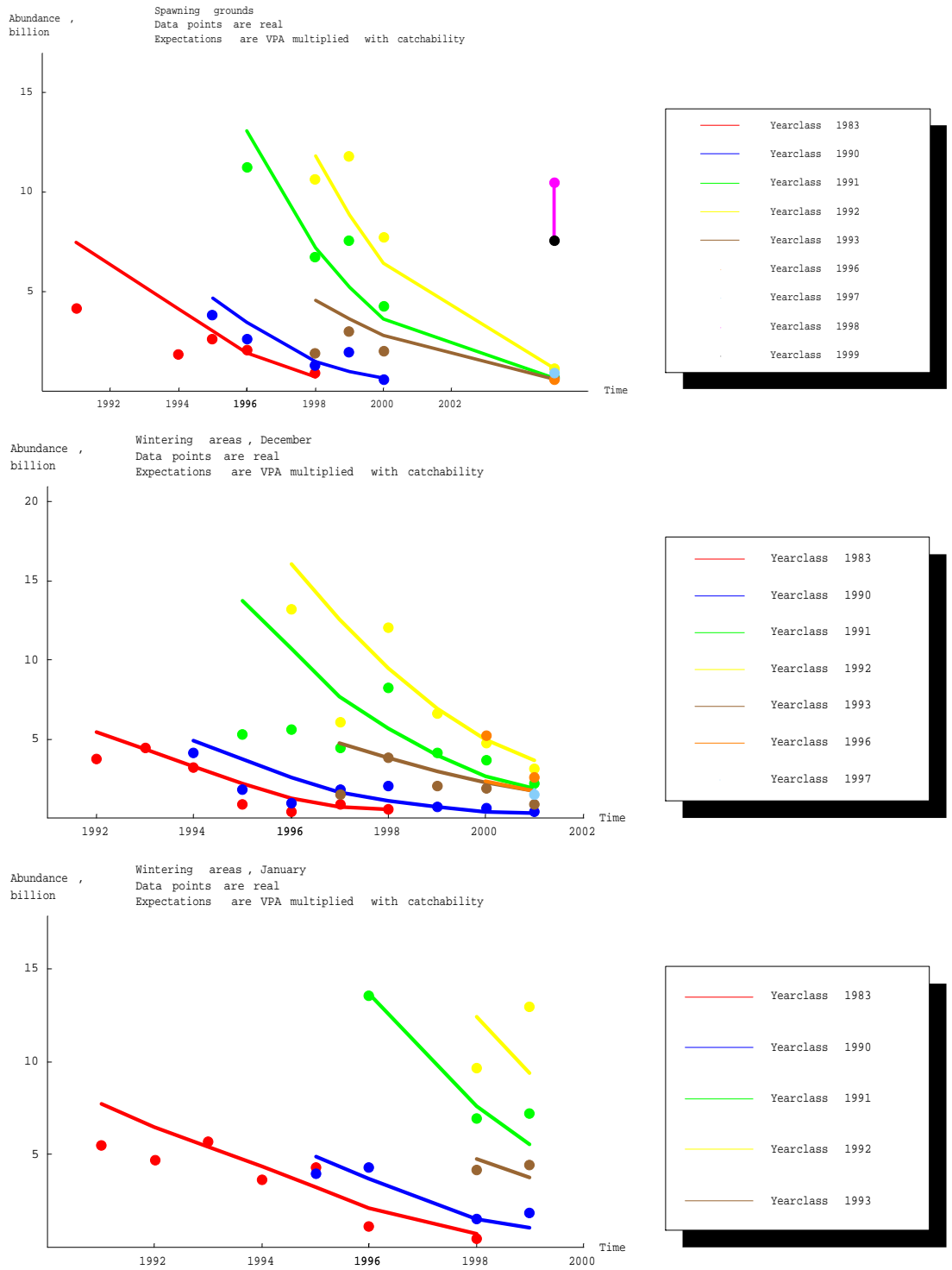

Figure 3.7.2.1.3 NSSH. Survey data and historic abundance scaled with catchability for the main SeaStar run, for surveys 1, 2, 3, 5, 4 and 6.

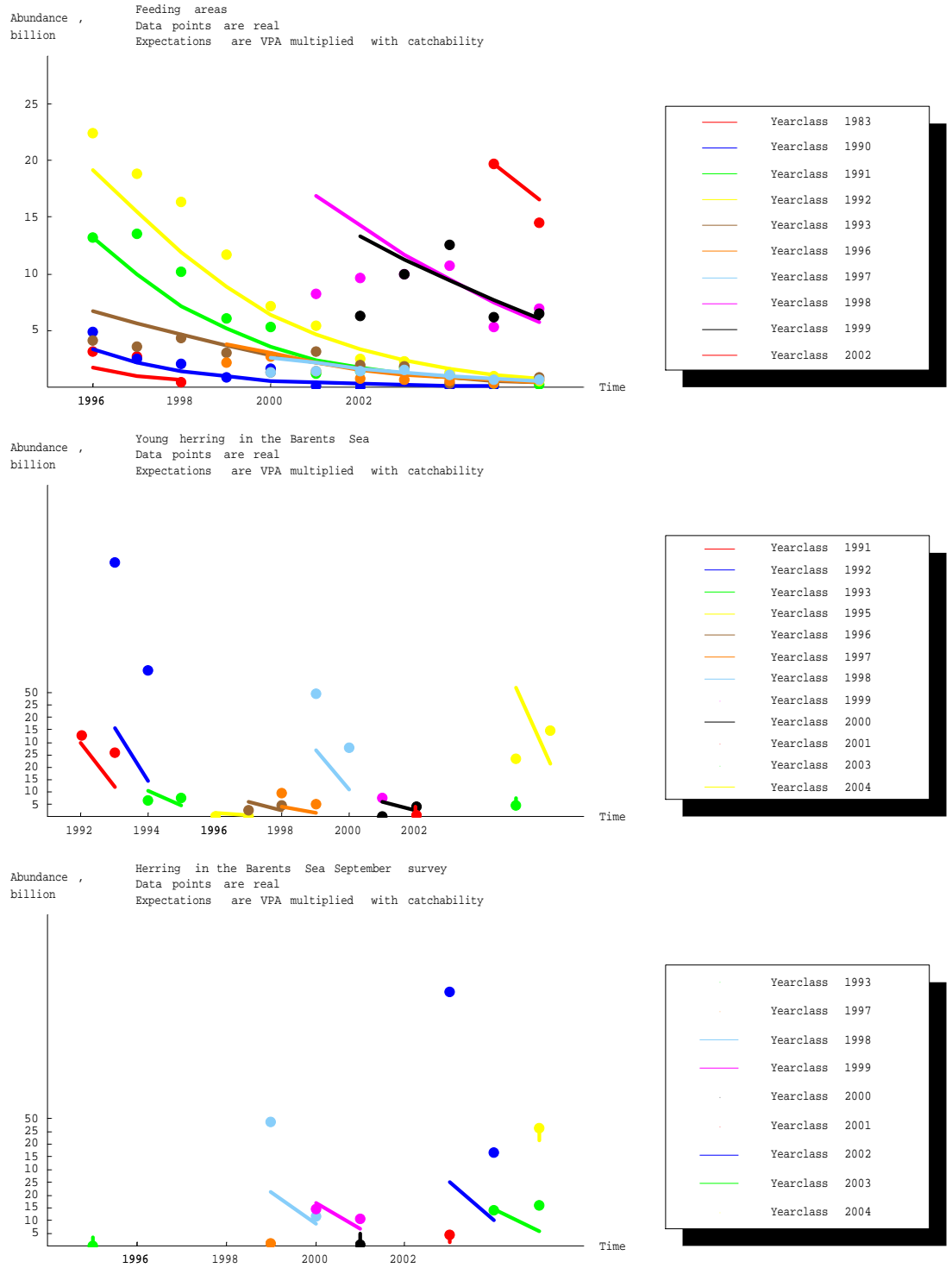

Figure 3.7.2.1.3 NSSH. Survey data and historic abundance scaled with catchability for the main SeaStar run, for surveys 1, 2, 3, 5, 4 and 6.

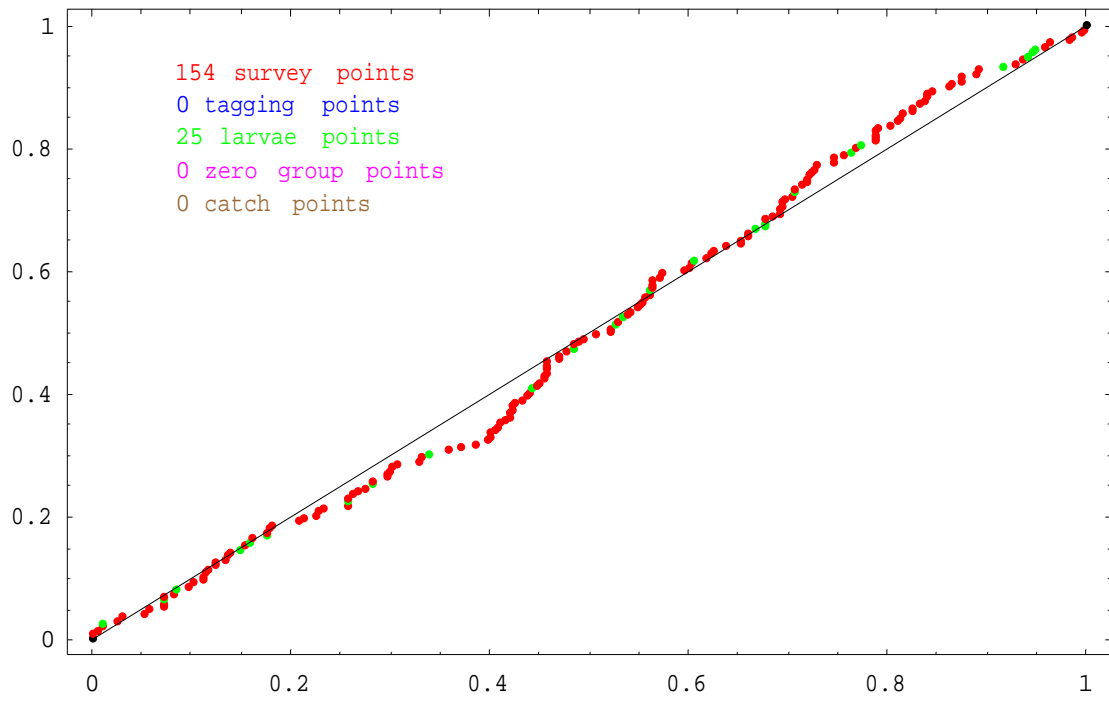

Figure 3.7.2.1.4. NSSH. Quantile-quantile plot the surveys on the adult stock and the larval data for the main SeaStar run.

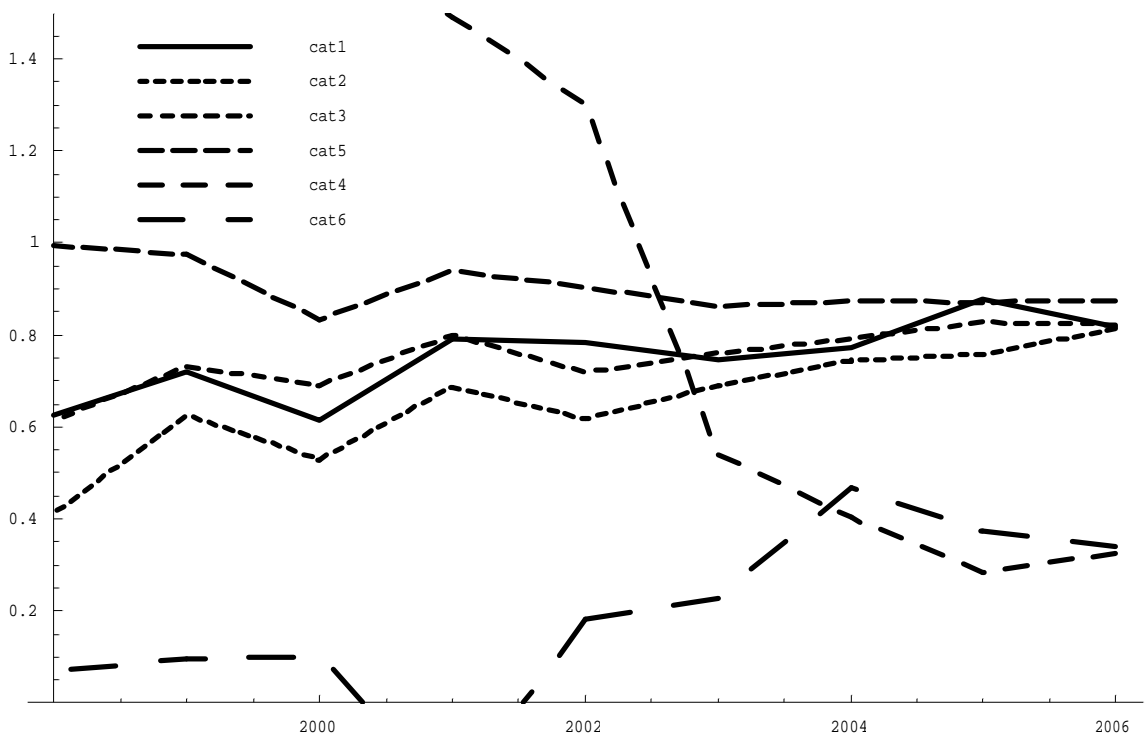
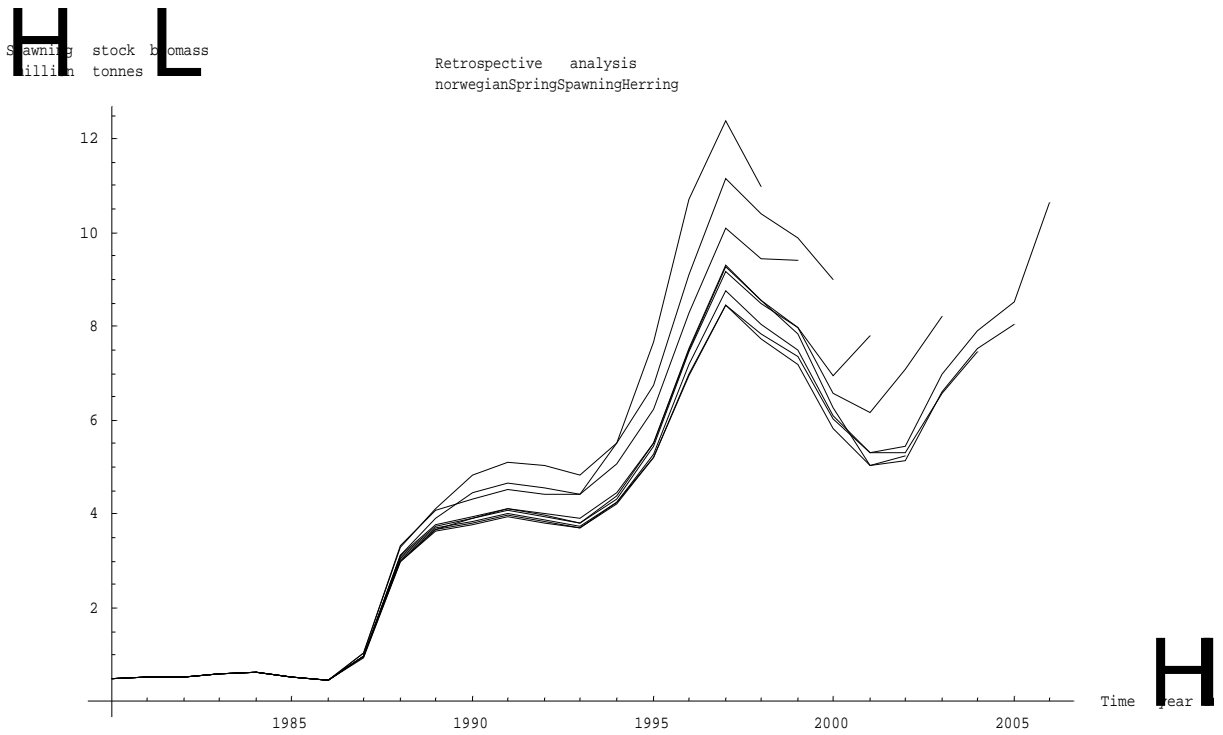
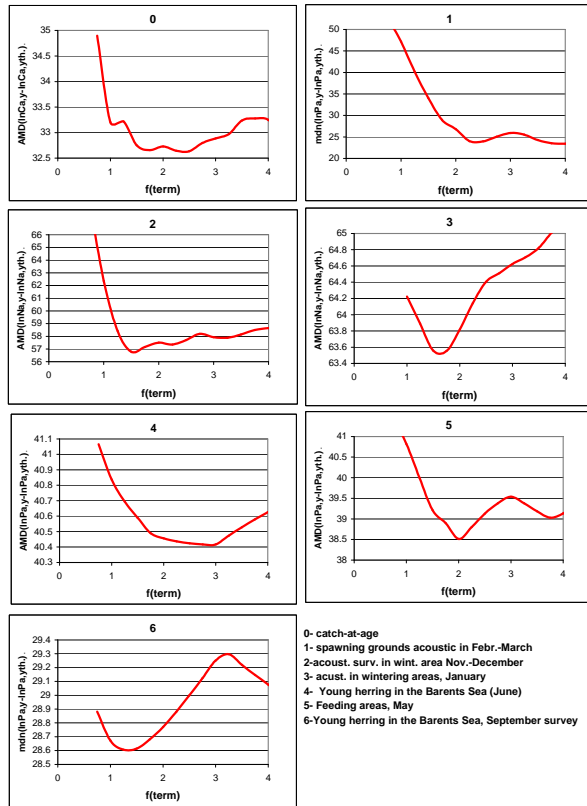
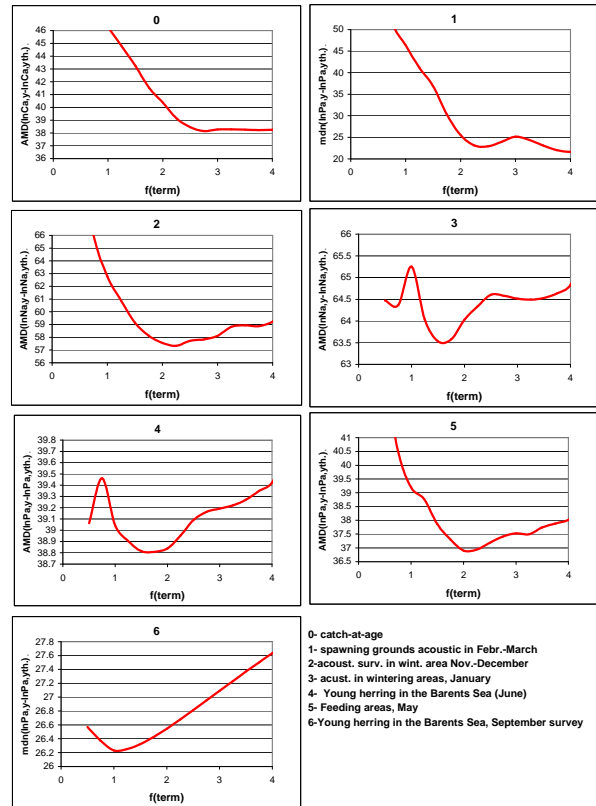

Figure 3.7.2.1.5. NSSH. Retrospective plot for the SeaStar main survey, SSB (upper) and survey catchabilities (lower).



a. TISVPA



b. ISVPA

Figure 3.7.2.2.1. NSSH. Profiles of components of the TISVPA and ISVPA loss functions

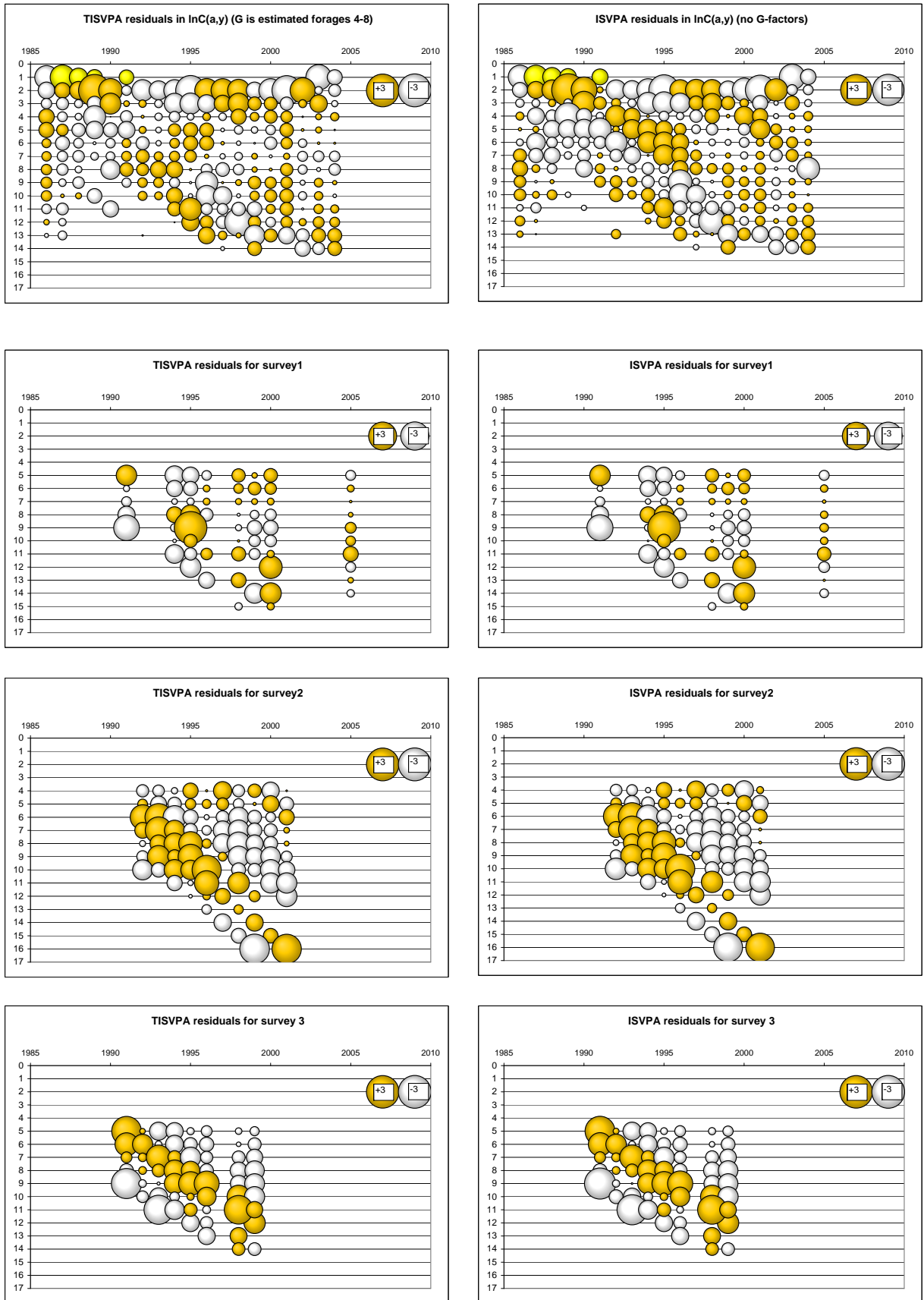

Figure 3.7.2.2.2 NSSH. Residuals in TISVPA and in ISVPA.

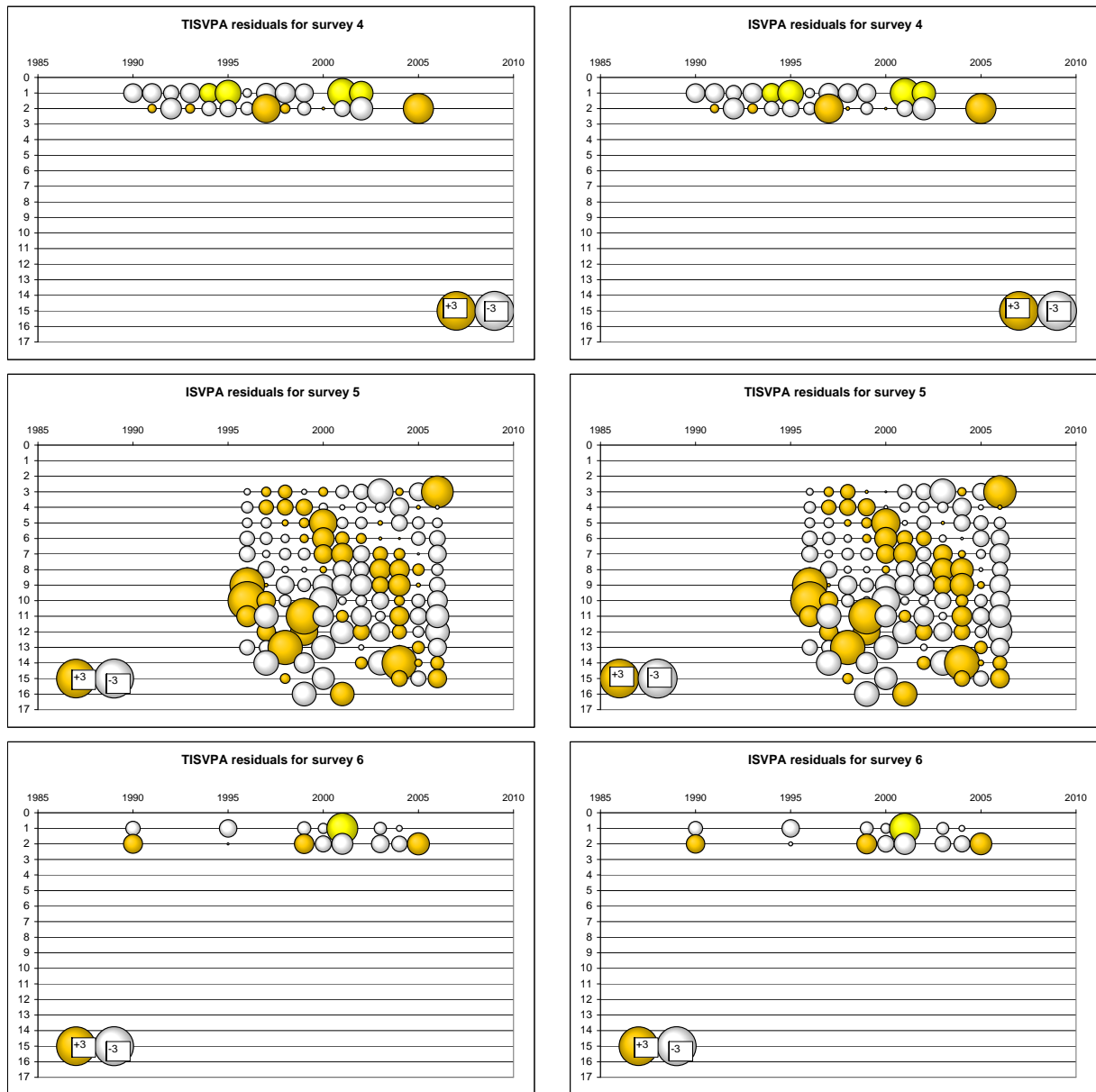

Figure 3.7.2.2.2 NSSH. Residuals in TISVPA and in ISVPA.

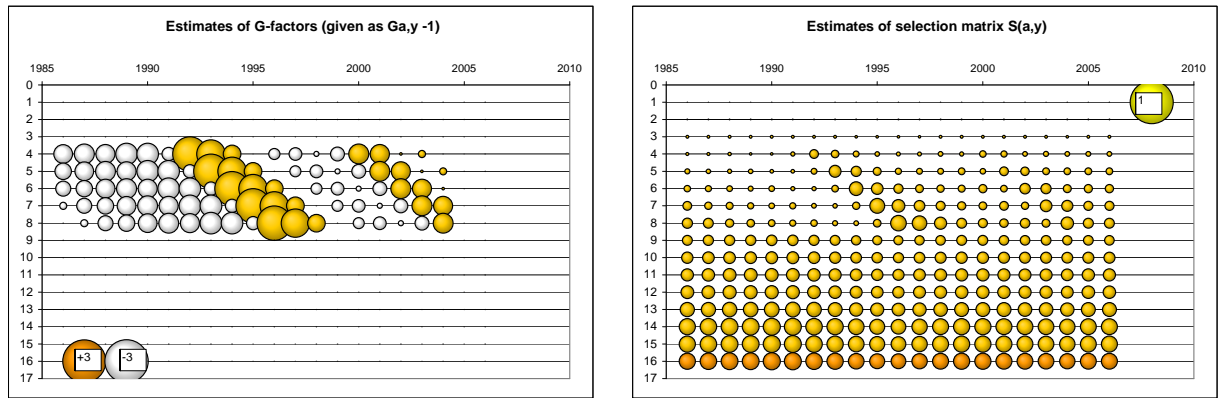
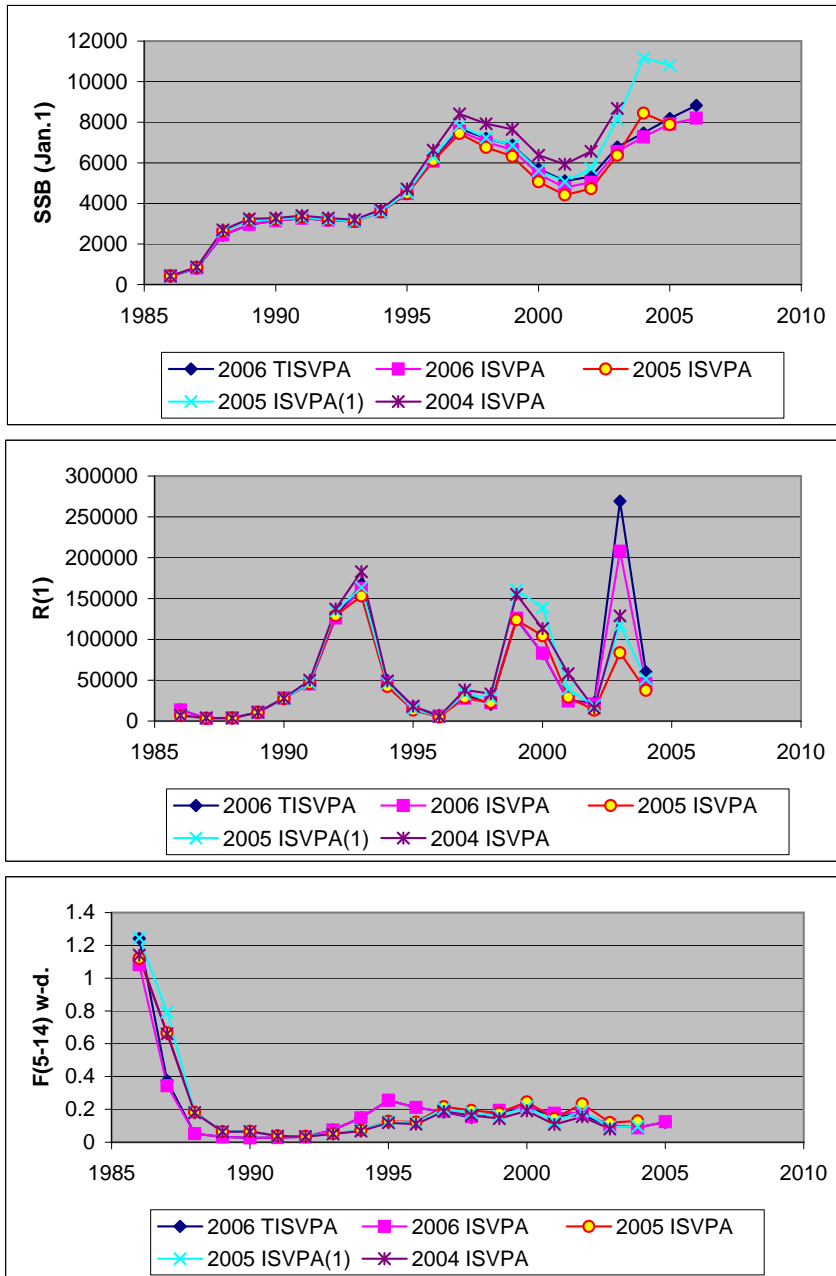

Figure 3.7.2.2.3. NSSH. TISVPA-derived estimates of generation-dependent factors and selection matrix.



2005 ISVPA - data with signals
 2005 ISVPA (1) - all data

Figure 3.7.2.2.4. NSSH. Comparison of the TISVPA and ISVPA results with the results of previous assessments by means of ISVPA.

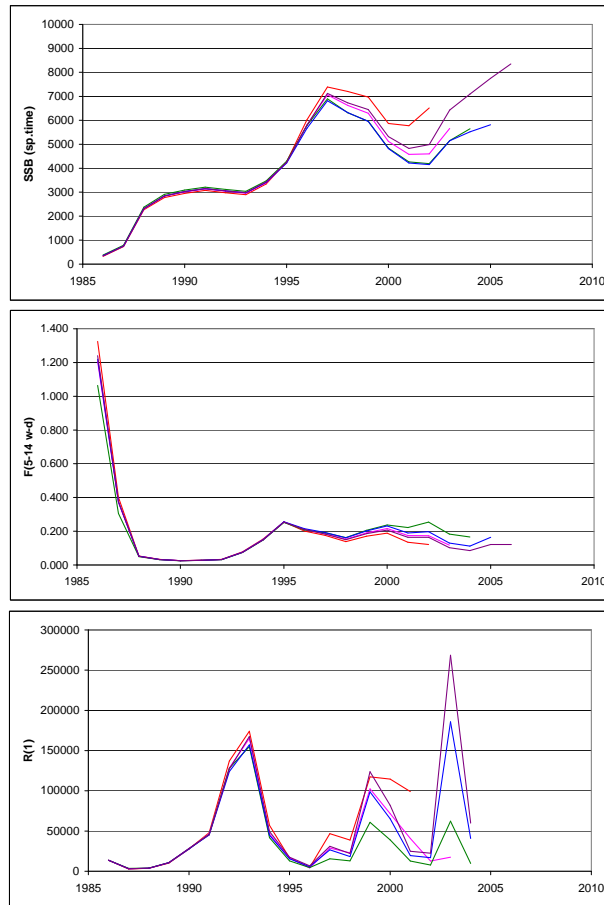

Figure 3.7.2.2.5. NSSH. Retrospective runs.

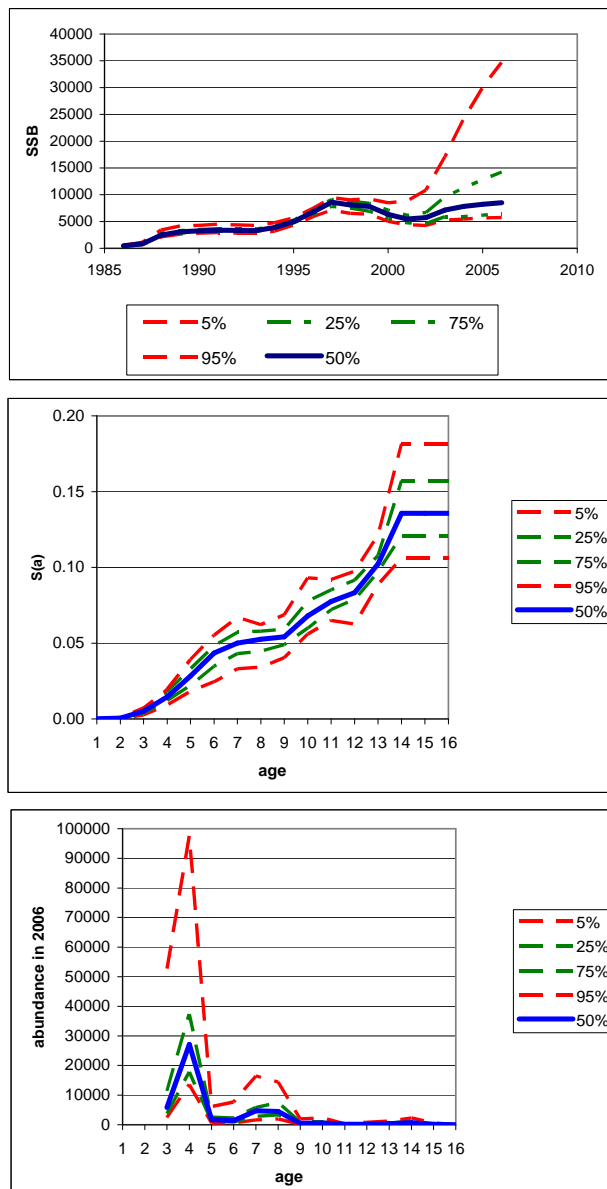

Figure 3.7.2.2.6. NSSH. Bootstrap.

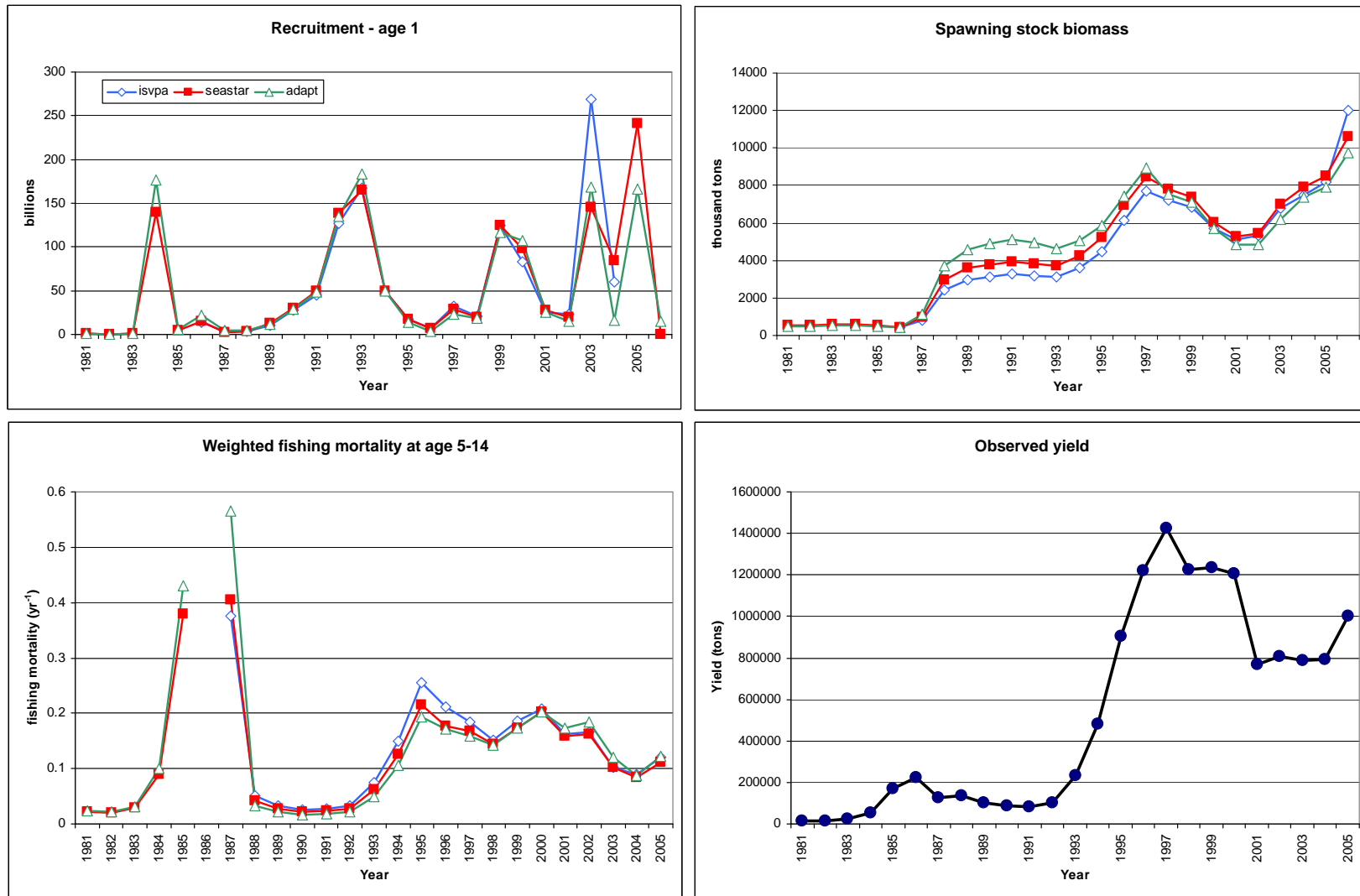

Figure 3.7.3.1 Norwegian spring spawning herring . Comparisons of results from assessments model ADAPT, ISVPA and SeaStar. (ISVPA from 1986).

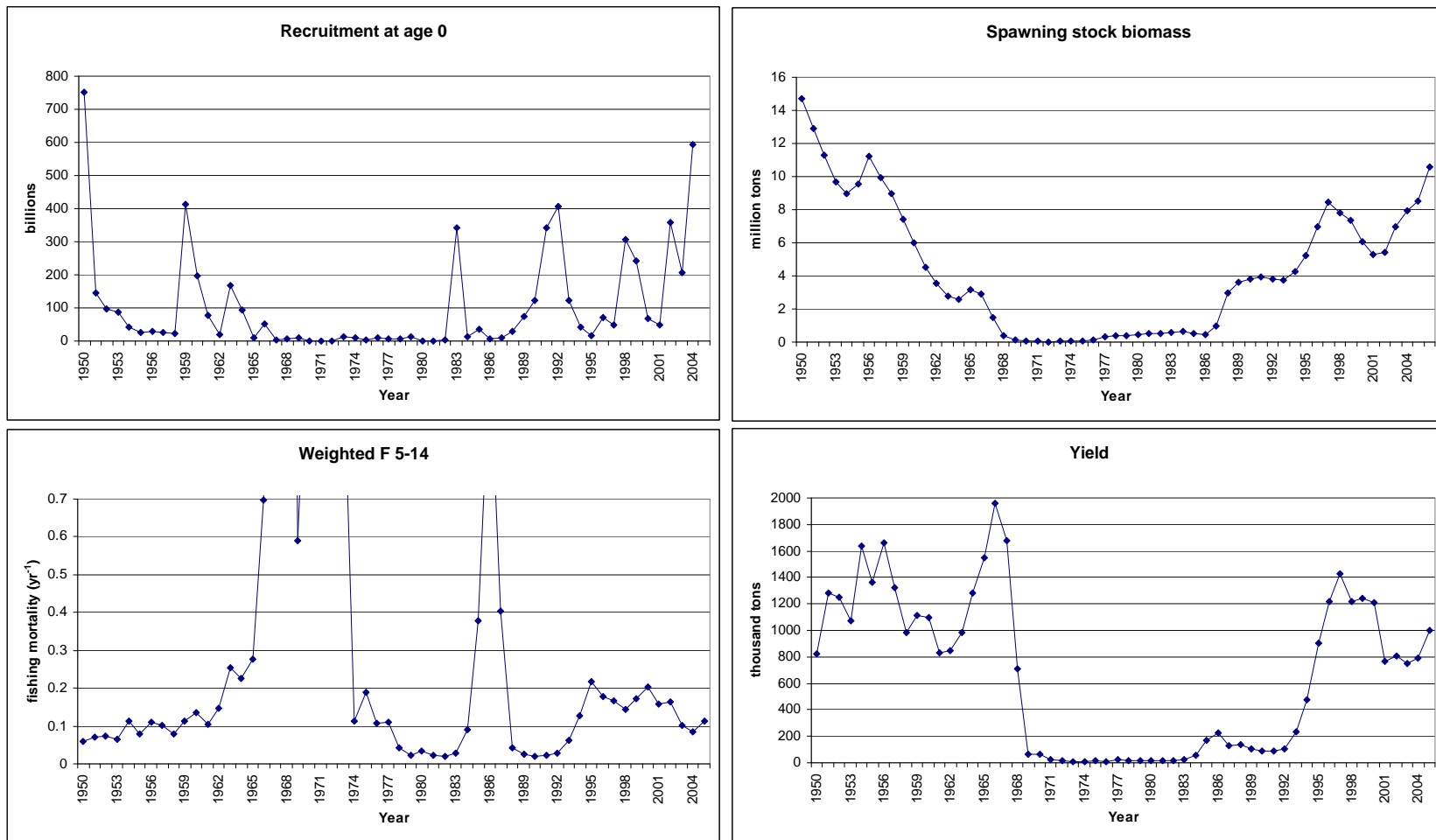

Figure 3.7.4.1. Norwegian spring spawning herring. Summary of final run.

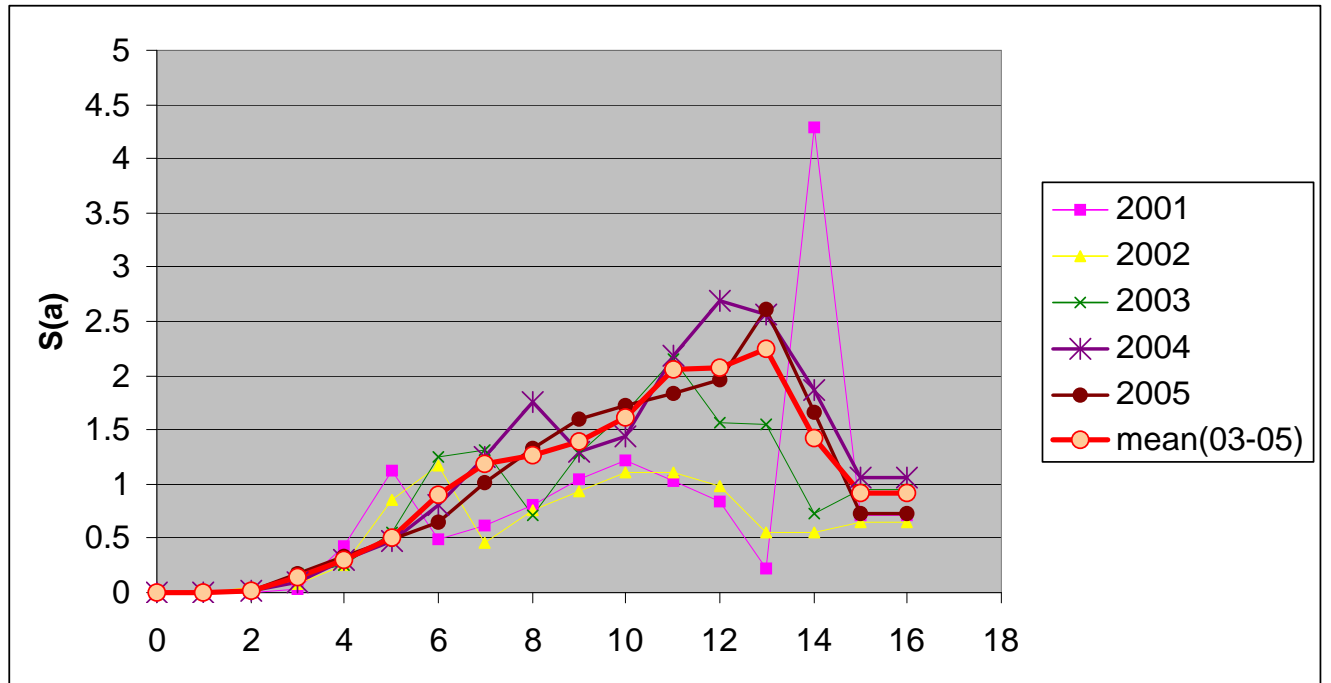

Figure 3.9.1.1. Norwegian spring spawning herring. The exploitation pattern in the years 2001-2005.

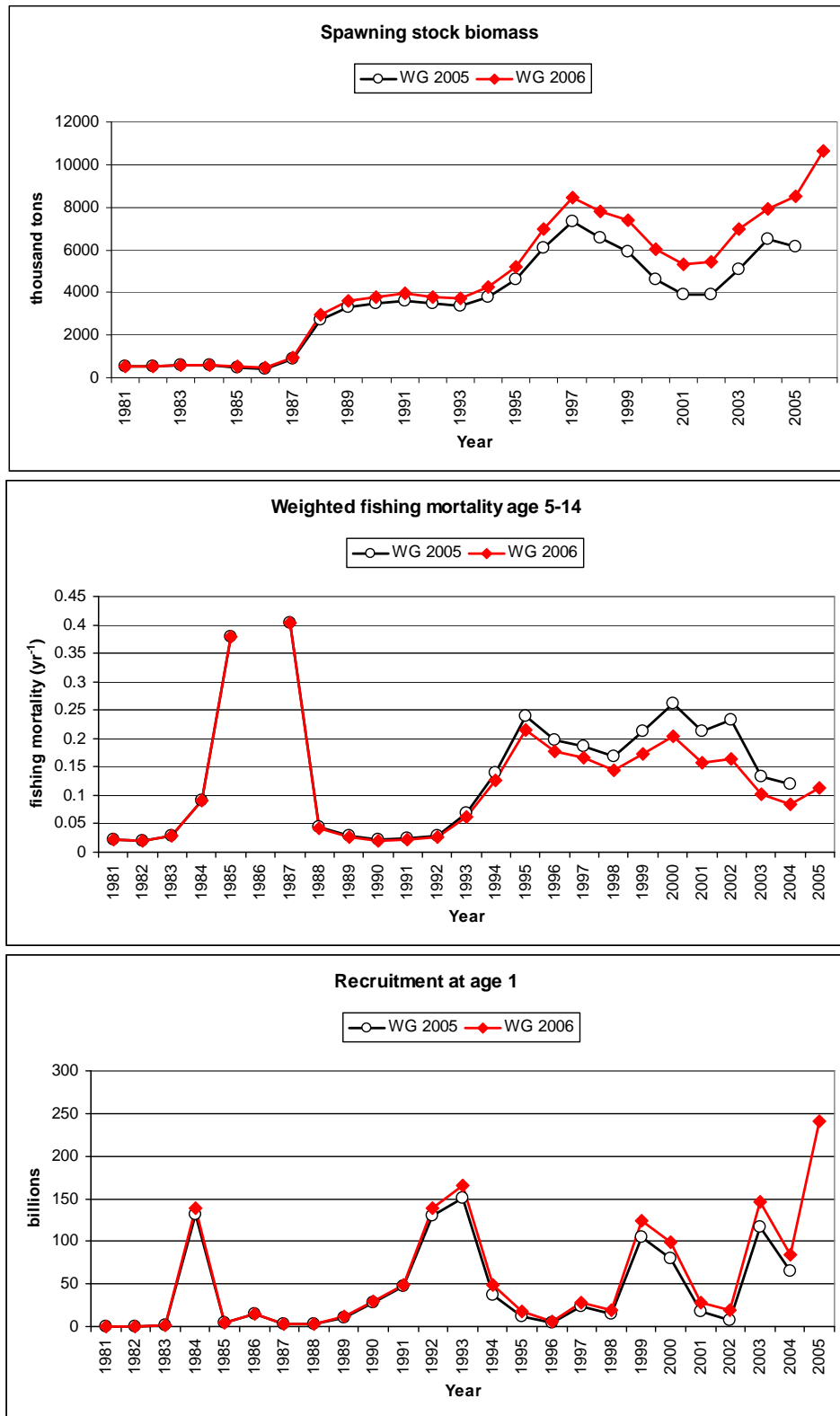

Figure 3.12.1. Norwegian spring spawning herring. Comparison of final assessments made in 2005 and 2006.

4 Blue whiting

4.1 Stock description

Blue whiting (*Micromesistius poutassou*) is a pelagic gadoid which is widely distributed in the eastern part of the North Atlantic. The highest concentrations are found along the edge of the continental shelf in areas II, V, VI where it occurs in large schools at depths ranging between 300 and 600 meter but is also present in almost all other management areas between the Barents Sea and the Strait of Gibraltar. The major spawning takes place in February and March, along the shelf edge and banks west of the British Isles. Juveniles are abundant in many areas, with the main nursery area believed to be the Norwegian Sea. Morphological, physiological, and genetic research has suggested that there may be several components of the stock which mix in the spawning area west of the British Isles (ICES C.M. 2000/ACFM:16). For assessment purposes blue whiting in these areas is treated as a single stock since it has so far not been possible to define an unambiguous border between populations (if separate populations exist).

4.2 ICES advice and management applicable to 2005 and 2006

In 1998 ICES defined limit and precautionary reference points for this stock: B_{lim} (1.5 mill.t.), B_{pa} (2.25 mill.t.), F_{lim} (0.51 yr⁻¹) and F_{pa} (0.32 yr⁻¹). The advice of ICES in following years has been given within a framework defined by these reference points.

In December 2002 EU, Faroe Islands, Iceland, and Norway agreed to implement a long-term management plan for the fisheries of the blue whiting stock, which is consistent with a precautionary approach, aimed at constraining the harvest within safe biological limits and designed to provide for sustainable fisheries and a greater potential yield. The plan should consist of the following:

1. *Every effort shall be made to prevent the stock from falling below the minimum level of Spawning Stock Biomass (SSB) of 1 500 000 tonnes.*
2. *For 2003 and subsequent years, the Parties agreed to restrict their fishing on the basis of a TAC consistent with a fishing mortality less than 0.32 for appropriate age groups as defined by ICES, unless future scientific advice requires modification of the fishing mortality rate.*
3. *Should the SSB fall below a reference point of 2 250 000 tonnes (Bpa) the fishing mortality rate, referred to under paragraph 1, shall be adapted in the light of scientific estimates of the conditions then prevailing. Such adaptation shall ensure a safe and rapid recovery of the SSB to a level in excess of 2 250 000 tonnes.*
4. *In order to enhance the potential yield, the Parties shall implement appropriate measures, which will reduce catches of juvenile blue whiting.*
5. *The Parties shall, as appropriate, review and revise these management measures and strategies on the basis of any new advice provided by ICES.*

In the absence of agreements on a TAC for 2002–2005, the Coastal States and the Russian Federation each unilateral implemented catch limits for these years.

In 2004 ICES concluded from the most recent estimates of fishing mortality and SSB that the stock had full reproduction capacity, but was harvested unsustainably. The management plan implies catches of less than 1.075 million t in 2005 which is expected to keep fishing mortality less than 0.32 with 50% probability. This will also ensure a high probability that the spawning stock biomass in 2006 will be above Bpa. The management plan point 4 calls for a reduction of the catch of juvenile blue whiting which has not taken place. ICES recommends that measures be taken to protect juveniles.

In 2005 ICES stated that fishing within the limits of the management plan ($F=0.32$) implies catches of less than 1.5 million t in 2006. This will also result in a high probability that the spawning stock biomass in 2007 will be above Bpa. The present fishing level is well above levels defined by the management plan and should be reduced. The management plan point 4 calls for a reduction of the catch of juvenile blue whiting which has not been taken place. The primary approach to reduce catch of juveniles is to reduce overall fishing mortality. Catches of juveniles in the last 4 years are much greater than in earlier periods. If an overall reduction of fishing mortality cannot be achieved then specific measures should be taken to protect juveniles.

4.2.1 Management plan for the blue whiting fishery

In December 2005, the coastal states (EU, Norway, Iceland and Faeroe Islands) agreed on a sharing arrangement for the blue whiting stock. This arrangement provides for catches in 2006 of 2 million tonnes, allocated as follows: EU 30.5%, Faeroe Islands 26.125%, Norway 25.745% and Iceland 17.63%. Russia will be accommodated by transfers from some of the coastal states and additional catches in the NEAFC regulatory area.

1. *A Delegation of the European Community, the Faroe Islands, Iceland and Norway met in Oslo on 15 and 16 December 2005 to consult on the management of the Blue Whiting stock in the North-East Atlantic.*
2. *The Delegations agreed to recommend to their respective authorities the arrangement for the regulation of the fisheries of Blue Whiting in 2006 and subsequent years set out in Annex I to this Agreed Record. They also agreed to recommend to their respective authorities the multi-annual management arrangement set out in Annex II.*
3. *The Delegations agreed to recommend that, in 2006, ICES be requested to evaluate, as soon as possible, whether the multi-annual management arrangement as set out in Annex II is in accordance with the precautionary approach and to make the results of this evaluation available to the Parties. The Delegations agreed to review the multi-annual management arrangement on the basis of evaluation by ICES.*
4. *This Agreed Record, including bilateral arrangements related to the implementation thereof, shall be applied provisionally from 1 January 2006 and enter into force when all Parties have notified each other of the completion of their necessary procedures.*
5. *For subsequent years, Delegations agreed to allocate allowable catches in the proportions that are set out in paragraph 1 of Annex I.*
6. *Unless one or more of the Parties notifies its withdrawal not later than by the end of June, the Agreed Record shall be renewed annually, including Annexes, in which years, maximum catch limit and quotas are updated.*
7. *The Delegations agreed to inform the NEAFC Secretariat about the regulatory measures they intend to take on the basis of this Agreed Record, for the fisheries of Blue Whiting in 2006 and in subsequent years.*

ANNEX I. ARRANGEMENT FOR THE REGULATION OF THE FISHERIES OF BLUE WHITING IN 2006

1. *In accordance with the multi-annual management arrangement for the fisheries of Blue Whiting set out in Annex II to this Agreed Record, the Parties agree to restrict their fisheries of Blue Whiting in 2006 to a maximum catch limit of 2,000,000 tonnes on the basis of the following quotas:*
 - *European Community 610,000 tonnes*
 - *Faeroe Islands 522,500 tonnes*
 - *Iceland 352,600 tonnes*
 - *Norway 514,900 tonnes*
2. *Each Party may transfer unutilised quantities of up to 10% of the quota allocated to it for 2006 to 2007. Such transfer shall be in addition to the quota allocated to the Party concerned for 2007.*

3. *In the event of overfishing of the allocated quotas by any Party in 2006, the quantity shall be deducted from the quota allocated in 2007 for the Party or Parties concerned.*
4. *The Parties may fish Blue Whiting within the quotas laid down in paragraph 1 in their respective zones of fisheries jurisdiction and in international waters.*
5. *Further arrangements by the Parties, including arrangements for access, quota transfers and other conditions for fishing in the respective zones of fisheries jurisdiction, are regulated by bilateral arrangements.*

ANNEX II. ARRANGEMENT FOR THE MULTI-ANNUAL MANAGEMENT OF THE BLUE WHITING STOCK

1. *The Parties agree to implement a multi-annual management arrangement for the fisheries on the Blue Whiting stock which is consistent with the precautionary approach, aiming at constraining harvest within safe biological limits, protecting juveniles, and designed to provide for sustainable fisheries and a greater potential yield, in accordance with advice from ICES.*
2. *The management targets are to maintain the Spawning Stock Biomass (SSB) of the Blue Whiting stock at levels above 1.5 million tonnes (Blim) and the fishing mortality rates at levels of no more than 0.32 (Fpa) for appropriate age groups as defined by ICES.*
3. *For 2006, the Parties agree to limit their fisheries of Blue Whiting to a total allowable catch of no more than 2 million tonnes.*
4. *The Parties recognise that a total outtake by the Parties of 2 million tonnes in 2006 will result in a fishing mortality rate above the target level as defined in paragraph 2. Until the fishing mortality has reached a level of no more than 0.32, the Parties agree to reduce their total allowable catch of Blue Whiting by at least 100,000 tonnes annually.*
5. *When the target fishing mortality rate has been reached, the Parties shall limit their allowable catches to levels consistent with a fishing mortality rate of no more than 0.32 for appropriate age groups as defined by ICES.*
6. *Should the SSB fall below a reference point of 2.25 million tonnes (Bpa), either the fishing mortality rate referred to in paragraph 5 or the tonnage referred to in paragraph 4 shall be adapted in the light of scientific estimates of the conditions then prevailing. Such adaptation shall ensure a safe and rapid recovery of the SSB to a level in excess of 2.25 million tonnes.*
7. *This multi-annual management arrangement shall be reviewed by the Parties on the basis of ICES advice.*

ICES was requested to evaluate the management plan in relation to the precautionary approach (see Section 4.13).

4.2.2 NEAFC regulatory measurements

In addition to the Coastal States management plan, the following regulatory measures for the Blue Whiting Stock for 2006 are suggested by NEAFC:

1. *NEAFC takes note of the Agreed Record of Conclusions of Fisheries Consultations on the Management of the Blue Whiting Stock in the North-East Atlantic for 2006 between the European Community, the Faroe Islands, Iceland and Norway signed in Oslo on 16 December 2005.*
2. *NEAFC further notes that by way of the said Agreed Record, the aforementioned Parties agreed to restrict their fishery on the Blue Whiting Stock in 2006 on the basis of specified quotas according to a total catch limitation of 2 million tonnes.*
3. *In accordance with Article 5 of the Convention on Future Multilateral Cooperation in North-East Atlantic fisheries, the Contracting Parties recommend the following measure for the Blue Whiting Stock for 2006.*
 - a. *In order to ensure consistency and compatibility with the said Agreed Record, NEAFC hereby establishes an allowable catch limitation of 253,000*

tonnes of Blue Whiting for 2006 in waters beyond the areas under national fisheries jurisdiction of the Contracting Parties

b. This allowable catch limitation shall be allocated as follows:

European Community 44 000 tonnes ()*

Norway 37 000 tonnes ()*

Denmark in respect of:

Faroe Islands 37 000 tonnes ()*

Greenland 10 000 tonnes

Iceland 25 000 tonnes ()*

Russian Federation 100 000 tonnes

() Catches taken under these allocations shall be deducted from quotas allocated to Parties to the said Agreed Record*

4. The quotas referred to in paragraph 2 may be fished in the areas defined in paragraph 3 a.

4.3 Description and development of the fisheries in 2005

Total catches figures in 2005 were provided by members of the WG. They were estimated to be about 2 million tonnes, 400 thousand tonnes less than last year. Time series with catches by nations and area are given in Tables 4.3.1-4.3.7.

The spatial and temporal distribution of the catches of blue whiting in 2005 is given by quarter and ICES rectangles in Figure 4.3.1 and 4.3.2. The distribution of the catch by ICES rectangles for the whole year is given in Figure 4.3.1. In 2005 the catch provided as catch by rectangle represented approximately 98% of the total WG catch.

Some details about vessels operated by different nations targeting blue whiting are given in Table 4.3.8.

Otherwise, a new database developed by ICES named InterCatch has been presented to the working group. The aim of it is to collect all the catch data information by country and compile them in an international database. For doing so, fleet-fishing activity matrix defined in Fleet-Fishing activity working group (Nantes, 2006) was used in WGNPBW. The group tried to identify blue whiting fishery in each country until Level 4 defined as EU level and in the Table 4.3.9 the identified fishing activities are shown.

The working group requests to all countries to submit the catch at age data and landing data split in the fleets identified in the above table.

4.3.1 Denmark

The Danish directed fishery blue whiting fishery is mainly conducted by trawlers using a minimum mesh size of 40mm. A limited fishery where mesh sizes between 16 and 32 mm also took place. The directed fishery blue whiting fishery in the western and northern areas constituted 61% (25,000 t) of the total Danish blue whiting fishery and this fishery mainly was conducted in March and April. The fishery in the North Sea was app. 16,000 t. All landing were landed for production of fish meal and oil.

4.3.2 Germany

The main fleet targeting pelagic species is based at Bremerhaven and Rostock. The vessels are owned by a Dutch company and operating under German flag. They consist of 3 large pelagic freezer trawlers of length greater than 90m up to more than 120m with hp between 4200 and 11000. The crew consists of about 35 to 40 men. The vessels are specially designed for pelagic fisheries. The catch is pumped into large storage tanks filled with cool water to keep the catch fresh until it is processed.

The blue whiting fishery is seasonal in the first and second quarter. In 2005 the fishery starts in divisions VIIc in February and continues in divisions VIIc, Vb and VIa during March and April until it ends in divisions Vb and VIa in May. Occasionally there is blue whiting by-catch in the herring directed fishery in IIa and b during summer. In other divisions there were only minor blue whiting catches.

4.3.3 Faroe Islands

The Faroese fishery (8-11 large vessels and 3 smaller vessels) started in January 2005 in the southeastern part of the Faroese EEZ (ICES Division Vb), and in late January the fleet moved to the Porcupine Bank area west of Ireland (Division VIIc and VIb) in the EU zone. In February the fishery continued in this area and moved gradually farther from the slope and also into International waters (Division VIb, VIIc and XII) where the fishery continued through March. In April the fleet had moved north to area south of the Faroes (Division Vb), where the fishery continued in May, June, and first half of July, with a gradual shift to the northwest in to the Icelandic zone (Division Va and IIa). In August and September the fishery was rather poor in the Faroe-Iceland zone as compared to 2004, and part of the fleet had moved north into the northern part of International waters, where the fishery continued in September (Division IIa and IIb). In south (Faroe-Iceland area) only scattered catches were taken. In October the fishery in north ceased and scattered catches were taken in the Divisions Va and Vb. The fishery improved again in November and December in the Faroese zone on the sloped north and northeast of the Faroes (Division Vb and IIa).

The industrial fleet (3 trawlers) operated mainly in Norwegian waters (Division IVa) in second quarter, with some catches in Faroese waters.

About 96% of the catches were taken with pelagic trawl the rest with pelagic pair-trawls.

4.3.4 France

The total French landings in 2005 were 8,046 t but no fishery description was available to the WG.

4.3.5 Iceland

Iceland and Faroes have a bilateral agreement of mutual fishing rights for blue whiting in each other's EEZs. Iceland set a total blue whiting catch quota of 345 000 tonnes in 2005 for Icelandic-Faroese and International waters.

The Icelandic directed fishery started in the second / third week of March in International waters west of the British Isles. In April, the fishery moved totally into Faroese waters. In May, the fishery gradually moved north and by the middle of the month, it was conducted both in Icelandic and Faroese waters. In June, the fishery continued both in Faroese and Icelandic waters but in July the fishery had moved entirely into the Icelandic EEZ. About 87% of the Icelandic catch was taken in the second quarter of the year. After July the Blue whiting dispersed away from the Iceland-Faroe Ridge area east and northeast into the Norwegian Sea resulting in poor catches the remainder of the year. In August and October the fishery was conducted in the Icelandic zone but in November and December it had moved to the Faroese area again. The total Icelandic catch was 265 515 tonnes.

A total of 25 trawlers/purse-seiners participated in the Icelandic fishery, as compared to 21 vessel in 2004, using large pelagic trawls with a 40 mm mesh size in the cod-end. The length range of the vessels was 55-105 meters with a mean length of 67 meters. The engine power range of the fleet was 1943-5920 kW (2500-8051 HP) with a mean of 3490 kW (4570 HP).

Iceland has set size limitations on landings of blue whiting. If the catch consists of 30% or more of fish smaller than 25 cm, a temporary area closure is imposed.

4.3.6 Ireland

The Irish fishery for blue whiting began in late January and continued until early May with the great majority of landings reported for March and April. A total of 25 boats took part and reported landings of 73,488 t. This is a small decline from 2004, when the Irish landings peaked at 75,000 t. Prior to 2004 the greatest landings reported were in 1998 when 46,000 t were landed.

The fleet is comprised of 24 pelagic or polyvalent licensed trawlers with RSW tanks and one freezer trawler. Participation in this fishery peaked in 2005 with nine of the largest boats in the fleet accounting for 90% of the total landings. Blue whiting from the Irish fleet is landed primarily for reduction to fishmeal with smaller but important amounts processed for human consumption. In 2005 around 22,000 t were landed for human consumption with 9,000 t of this coming from the single freezer trawler in the fleet. The remaining 13,000 t were landed from RSW vessels fishing close to the main Irish pelagic port of Killybegs and processed onshore.

Fishing took place to the west and north of Ireland on spawning and post spawning aggregations with 95% of the landings from ICES areas VIIc and VIa. The remaining landings were primarily overspill into adjacent statistical areas and rectangles. Fishing was concentrated in those rectangles along the shelf edge in waters of between 300 and 600m in depth.

4.3.7 Netherlands

The Dutch fleet fishing for pelagic species in European waters consists of 14 freezer trawlers and one pair trawler. In addition, a number of flag vessels are operating from the Netherlands. Target species of this fleet are: herring, blue whiting, mackerel, horse mackerel and argentines. Some of these trawlers are also fishing for sardinella and horse mackerel in west African waters during part of the year. The fishery for blue whiting is carried out with large pelagic trawls and is a directed fishery with almost no bycatch of other species. Catches increased in 2005 compared to 2004. Most of the catches in 2005 originated from ICES Division VIa and VIIc and were taken in the first half of the year. All catches are landed frozen for human consumption.

4.3.8 Norway

In the beginning of 2005, directed fisheries in the Norwegian EEZ, Jan Mayen zone and international waters were not regulated with quotas. Similarly, there was no quota regulation for the mixed industrial fishery in the Norwegian EEZ in the North Sea and Norwegian Sea (areas east of 4°W). However, on May 12th, fisheries north of 62°N in the aforementioned areas was closed. The fishery was again opened on July 18th with the joint maximal quota set to 890 000 t.

Through international agreements, 120 000 t in the EEZ of EU (of which up to 40 000 t could be taken by the mixed industrial fishery in the ICES area IVa) and 36 200 t in the Faroese zone were made available to the Norwegian fleet. The main Norwegian fishery is a directed pelagic trawl fishery, regulated by vessel quotas (in 2005, these were only in effect in the EU and Faroese zone), and is carried out on and west of the spawning areas west of the British Isles and in the Norwegian Sea using pelagic trawls with minimum mesh size of 35 mm. A total of 46 large combined purse seiners/trawlers took part in the fishery in 2005.

Blue whiting were also fished in the North Sea and in the southern Norwegian Sea (areas east of 4°W) in the mixed industrial fishery targeting blue whiting and Norway pout. These vessels use small-meshed trawls operated close to the bottom (minimum mesh size 16 mm) or pelagic trawls with minimum mesh size of 35 mm. These vessels operate under two different licenses. "North Sea trawler license" allowed fishing for blue whiting south of 64°N. These are mostly

small vessels that catch insignificant amounts of blue whiting (<0.1% of Norwegian catch) as by-catch; in 2005 only one vessel with this license fished blue whiting. "Industrial trawler license" allowed fishing for blue whiting in all areas except for in the EU and Faroes zones (notice that before 2004 these vessels were only allowed to fish blue whiting south of 64°N). 53 vessels with this license took part in the fisheries. These vessels caught some 15% of the total Norwegian catch.

In 2005, as usual, there was a seasonal progression of the fishery from the international waters off Porcupine Bank and Rockall in the beginning of the season (January-March) towards the shelf edge in EU zone and the banks in the Faroese waters in the end of the spawning season. The start of the season was good and record high catches were taken in February-March. However, the combination of high fuel prices and low catch rates led to withering of the fishery towards end of April, and the fisheries north of 62°N were closed on May 12th. The quotas in the EU and Faroese zones were not fully utilized. When the fisheries north of 62°N were again opened, the catch rates were too low for the directed fishery. The industrial fisheries, however, continued throughout the year.

According to the official statistics, the catch in the directed fishery was about 632 800 tonnes. In the industrial mixed fishery, 106 000 tonnes were taken. No corrections to account for by-catches or biases in reporting catches from the mixed industrial fisheries were made.

4.3.9 Portugal

The total Portuguese landings were 5190 t. New fishery information was not available to the Working Group.

4.3.10 Russia

The blue whiting fishery was carried out during the whole year. Up to 12 vessels of different types participated in this fishery in January-early February. Fishing grounds were situated in the central-eastern and southern parts of Faroes EEZ. The last one was used again from April, when the number of vessels increased gradually up to 28 units. The fishery in the central part of the Norwegian Sea started in the end of April. The main fishery was shifted there in July and continued till November. It was most active in October when the vessels were distributed between 61° and 75°N. The main effort was returned to the southern part of the sea in November.

The BW-fishery in the Rockall area was carried out from 13 February to 11 April. 80% of the effort was applied in March. The earlier spawning peak than in the last year was observed. No significant difference in fish length between 2004 and 2005 was detected in the catches. No appreciable difference in CPUE was noted in majority of vessel types as compared to the last year. However, same types of vessels operated more successfully. Totally 66 thousand t were taken in the spawning area by pelagic trawls. The blue whiting by-catch amounted to 1604 t in the bottom fishery in March-September.

The total Russian catch in 2005 was 332226 t.

4.3.11 Spain

The Spanish blue whiting fishery was carried out mainly by bottom pair trawlers in a directed fishery and by single bottom trawlers in a by-catch fishery, and small quantities were also caught by long-liners. These coastal fisheries have trip durations of 1 or 2 days and catches are for human consumption. Thus, coastal landings are rather stable due mainly to market forces.

Pair Bottom Trawl Fishery: The Pair bottom trawl is a traditional fleet that fish mainly blue whiting (above 80%) and other pelagic species in Div. VIIIc and North IXa. In the middle of 90's, VHVO gear (with 25 m of vertical opening) was gradually substituting the traditional

one. From 2001 the cod end mesh size was increased to 55 mm. This fleet is composed of 68 pairs (136 vessels) with an average of 25 m length, 472 HP, and 145 GRT. The pair trawler fleet landings were taken mainly on the border between Divisions VIIIc and IXa.

Bottom Trawl Mixed Fishery: This metier operates in Divisions VIIIc and IXa North, using a cod end mesh size of 65 mm and a vertical opening of 1.2-1.5 m. It targets a wide range of species including horse mackerel, blue whiting, mackerel, hake, anglerfish, megrims, and *Nephrops* (the first three species contributes around 70% of the landings). At present it is composed of around 235 vessels, with an average of 27 m length, 561 HP, and 177 GRT.

Spanish landings increased around 13 % in 2005 with a landing of 17643 tones. The landings area increasing year by year after the low value observed in 2003, partly explained by the closure of the fishery in some fishing grounds and ports, due to the sinking of the oil tanker "Prestige" in Galician waters in December 2002.

4.3.12 Sweden

The total Swedish landings were 2,960 t. These landings have been included in the total WG catch tables but owing to the late report of this information to the working group, these landings were not used in the assessment. The main catches were caught in the directed fishery (ICES Divisions IIa and IIIa) in the 3rd quarter of the year.

4.3.13 UK (Scotland)

The fishery started at the end of February 2005 and the first landing was on the 25th February and fishing continued until the end of April, the last landing was actually on the 30th April.

Thirteen pelagic trawlers took part in the fishery. Vessels length is between 50 and 70 metres length, and the horsepower is between 2300 and 8000 HP.

Almost 50% of the catch was landed into Denmark whilst the remainder was split between Scotland, Faroe and Iceland.

4.4 Bycatches in the fishery

Reports have been given on by-catch of other species, particular cod and saithe, in the pelagic fishery for blue whiting in the last three Working Group reports. The knowledge on by-catch is generally very sparse in this fishery, but Iceland and the Faroes have continued investigations of by-catch.

In last years report it was recommended to use a sorting grid in the mid-section of the trawl in order to prevent large fish, such as saithe and cod, to enter the cod-end, and thus minimise by-catch in the pelagic fishery. In Iceland it has been mandatory to use a sorting grid in certain areas east of Iceland where high by-catch rates have been observed. The Faroese authorities have decided to introduce a sorting grid in all pelagic fisheries in the Faroese zone from 1 January 2007 to limit by-catch of non-targeted species.

4.4.1 Icelandic investigations (land based sampling)

During May-December 2004 by-catch in the Icelandic blue whiting fishery in Icelandic and Faroese waters was analysed. From 42 trips (10.0% of all trips) 411 samples were collected in a randomised manner. By-catch species in the samples were quantified and length measured. In general, by-catch was a relatively rare occurrence, but associated with rather wide confidence limits.

The program was continued in 2005 but results were not available at the time of the meeting, except for preliminary estimates of total bycatch. The estimate is 1000 tonnes of saithe (2000

t in 2004) and 600 tonnes of cod (1000 t in 2004). The results from the sampling in 2004 have been analyzed by Pálsson (2005).

4.4.2 Faroese investigations at sea

Faroes initiated screenings on board a large factory trawler (M/T Næraberg) in May and June 2005. The by-catch rates were low on the Faroe-Iceland Ridge, especially on the Faroese side (Fig. 4.4.2.1). By-catch from the Russian fleet operated in the Faroese waters in late 2005 is shown in Fig 4.4.2.2.

4.5 Fishery dependent data

4.5.1 Sampling intensity

In total 1833 samples were collected from the fisheries in 2005. 217937 fish were measured and 32184 were fish aged. Sampled fish were not evenly distributed throughout the fisheries (see text table below).

Quarter	Fisheries	Directed	Mixed	Southern	Total
1	No. of samples	373	27	104	504
	WG Catch	871560	5309	5514	882383
2	No. of samples	415	107	124	646
	WG Catch	803133	38817	14723	856673
3	No. of samples	160	78	81	319
	WG Catch	107539	42340	5550	155429
4	No. of samples	161	75	128	364
	WG Catch	104522	22854	5092	132467
Total No. of samples		1109	287	437	1833
Total WG Catch		1886753	109320	30879	2026952

Considering the proportion between catches and sampling, the most intensive sampling took place in the southern fishery of Spain and Portugal. Here one sample was taken for every 70 tonnes, followed by the mixed fishery with one sample for every 381 tonnes, and lastly the directed fishery where there was one sample for every 1701 tonnes caught. In this context it should be noted that implementation of the EU Collection of Fisheries Data, Fisheries Regulation 1639/2001, requires a minimum of one sample to be taken for every 1000 t landed. Detailed information on the number of samples, number of fish measured, and number of fish aged by country and quarter is given in Table 4.5.1.1 and 4.5.1.2. As can be seen, no sampling was carried out by Germany, Sweden and France.

4.5.2 Landings

Most of the catches are taken in the directed pelagic trawl fishery in the spawning and post-spawning areas (Divisions Vb, VIa,b, and VIIb,c). Catches are also taken in the directed and mixed fishery in Subarea IV and Division IIIa, and in the pelagic trawl fishery in the Subareas I and II, in Divisions Va, and XIVa,b. These fisheries in the northern areas have taken 340 000–2 300 000 t per year in the last decade, while catches in the southern areas (Subarea VIII, IX, Divisions VIId,e and g-k) have been stable in the range of 20 000–85 000 t. In Division IXa blue whiting is mainly taken as by-catch in mixed trawl fisheries.

In the last few years the proportion of landings originating from the Norwegian Sea has increased from 5% in the mid-1990's to 40% in recent years (Figure 4.5.2.1). This has implications for the stock assessment as much larger proportions of juvenile fish occur in

catches from the Norwegian Sea, thus probably changing the exploitation pattern of the fishery as whole.

4.5.3 Discards

Discarding of blue whiting is thought to be small. Most of the blue whiting is caught in directed fisheries for reduction purposes. However, some discarding occurs in the fisheries for human consumption and as bycatch in fisheries directed to other species.

The Netherlands reported discarding of blue whiting in 2005 (around 1% in weight) from observations carried out in the EU data collection framework. Most of these discards were reported to be associated with net damage.

Also information of discards was available for Spanish fleets. Blue whiting is a bycatch in several bottom trawl fisheries directed to a mixture of species. In general the catch rates of blue whiting in these fisheries are low and most of the catch is discarded and only last day catch may be retained for marketing fresh. The estimates of discard in mixed fisheries in 2005 ranged between 25 and 90% (In weight). In the directed fishery for blue whiting for human consumption with pair trawls, discards were estimate to be 15% (in weight) in 2005. Discarding of the Spanish fleet in 2005 is not included in the assessment.

It was reported last year to the WG that no discarding of blue whiting occurs in Icelandic, Russian, Faroese and Danish fisheries. No data were available from all other countries.

4.5.4 Age and length composition of catches

Data on the combined length composition of the 2005 commercial catch by quarter of the year from the directed fisheries in the Norwegian Sea and from the stock's main spawning area were provided by the Faroes, Iceland, Ireland, Germany the Netherlands, Norway, Russia and Scotland. Length composition of blue whiting varied from 7 to 47 cm, with 91% of fish ranging from 21–32 cm in length. The mean length in this fishery was 26.2 cm (Table 4.5.4.1). Length compositions of the blue whiting catch and by-catch from “other fisheries” in the Norwegian Sea and the North Sea and Skagerrak were presented by Norway (Table 4.5.4.2). The catches of blue whiting from the mixed industrial fisheries consisted of fish with lengths of 7–44 cm and a mean of 22.9 cm. Ireland, Scotland, Germany, the Netherlands, France, Spain and Portugal caught blue whiting in the Southern area. The Spanish and Portuguese data used for length distribution of catches showed a length range from 15–40 cm with a mean length of 22.9 cm (Table 4.5.4.3).

For the directed fisheries in the northern area in 2005, age compositions were provided by Denmark, the Faroe Islands, Iceland, Ireland, Norway, the Netherlands, Russia and Scotland and the sampled catch accounted for 98 % of the total catch. Estimates of catch in numbers for unsampled catches were raised according to the knowledge of how, where, and when the catches were taken. The age compositions in the directed fisheries are given in Table 4.5.4.4.

Age compositions for blue whiting by-catches from “other fisheries” in the North Sea and Skagerrak were provided by Norway, Denmark, Faroe Islands and Russia and sampled catch accounted for 97% of catches. These data were used for allocation of the remaining part of the total in that area. The age compositions are given in Table 4.5.4.5.

For the fisheries in the Southern area, age composition representing 100% of the catch were presented by Spain and Portugal. The age compositions in the southern fishery data are given in Table 4.5.4.6.

The combined age composition for the directed fisheries in the Northern area, i.e. the spawning area and the Norwegian Sea, as well as for the by-catch of blue whiting in “other fisheries” and for landings in the Southern area, were assumed to represent the overall age

composition of the total landings for the blue whiting stock. The catch numbers-at-age used in the stock assessment are given in Table 4.5.4.7. The 2000, 2001 and 2002 year classes were the most numerous in the catches. To calculate the total international catch-at-age, and to document how it was done, the program SALLOC was used (ICES 1998/ACFM:18). The allocations are shown in the Annex II.

Catch in numbers in 2004 were updated with information on French landings in 2004 and numbers at age were raised assuming that French landings had the same age composition as total landings.

4.5.5 Weight at age

Mean weight-at-age data were available from Denmark, the Faroes, Iceland, Ireland, the Netherlands, Norway, Portugal, Russia, Scotland and Spain. Mean weight-at-age for other countries was based on the allocations shown in the Annex II (“ALLOC” files) and was estimated by the SALLOC program for the total international catch. Table 4.5.5.1 shows the mean weight-at-age for the total catch during 1982–2005 used in the stock assessment. There is a general trend towards lower weight-at-age. The weight-at-age for the stock was assumed to be the same as the weight-at-age for the catch.

4.5.6 Length at age

Mean length-at-age data were available from Denmark, the Faroes, Iceland, Ireland, the Netherlands, Norway, Portugal, Russia, Scotland and Spain. Mean length-at-age for other countries was based on the allocations shown in the Annex II (“ALLOC” files) and was estimated by the SALLOC program for the total international catch. Table 4.5.6.1 shows the mean length-at-age for the 4 main fisheries and the total catch in 2005.

4.5.7 Maturity at age

Maturity-at-age used in the assessment was obtained by combining maturity ogives from the southern and northern areas, weighted by catch in numbers-at-age (ICES 1995/Assess:7). These are the same as those used since 1994 (Table 4.5.7.1). Although the values of maturity-at-age probably are too low, sufficient information for estimating new ogives is not available.

4.5.8 Natural mortality

The possible need for revising the current estimate of instantaneous natural mortality rate M for blue whiting was discussed in detail by the 2002 WG. Although it was admitted that the current estimate $M=0.2 \text{ yr}^{-1}$ might be too low, the factual basis for revision was ambiguous. More recent methodological work by WGMG (ICES 2003/D:03) emphasizes that natural mortality rate cannot be estimated reliably with information normally available for stock assessment models. WG therefore considers that there is no new information that would justify a revision of the current estimate of M .

4.5.9 CPUE data

4.5.9.1 Spanish pair trawl CPUE

The Spanish pair trawls CPUE series (Table 4.5.9.1.1) has been used for several years as a tuning fleet in the blue whiting assessment. This fleet represents only a small part of the landings caught in a small part of the distribution area. Due to this fact, and following a recommendation of the Methods working group (ICES 2003/D:03), this tuning series is not used in the assessments anymore. No data are available to update this time series from 2004 onwards. Data show a slight decreasing trend in CPUE (Figure 4.5.9.1.1).

4.5.9.2 Norwegian CPUE

CPUE data in the spawning area has been collected from the Norwegian commercial fleet 1982–2003; the time series is shown in Figure 6.4.3.2 in the WG report from 2004. The time series is not updated. The data are not considered to be representative for the development of the stock and are not used in the assessment.

4.5.10 Effort data

No effort data are available as a measure of activity of the fisheries directed towards the blue whiting stock. The absence of quantitative data demonstrating changes in the fishery is considered to be a handicap in interpreting differences in the results of different assessments

4.6 Fishery independent data

4.6.1 International Blue Whiting survey on the spawning grounds

Background and status:

An international blue whiting spawning stock acoustic survey is carried out on the spawning grounds west of the British Isles in March–April. The survey started in 2004 and is an extension of the Norwegian survey described in section 4.6.1.2. The survey is carried out by Norway, Russia, EU (Ireland and Netherlands), and in 2005 the Faroes joined the survey. This international survey with broad international participation allowed for broad spatial coverage of the distribution of the stock as well as a relatively dense net of trawl and hydrographical stations. A description of the survey is given in the reference. The survey is coordinated by PGNAPES (ICES CM 2005/D:09).

Results:

The highest concentrations were recorded in the area between the Hebrides, Rockall and the banks southwest of the Faroes. In comparison to 2005, the biomass was more evenly and more southerly distributed, with more fish close to the traditional hot spot close to the Hebrides shelf brake. The distribution of acoustic backscattering densities for blue whiting as recorded by the six vessels is shown in Figure 4.6.1.1. The blue whiting spawning stock estimates based on the international survey are given in the table below. The 2006 estimate of SSB is about 30% higher than in 2005. An age-disaggregated total stock estimate is presented in Table 4.6.1.1, showing that the SSB was dominated by blue whiting of 4 and 3 year olds (year class 2002 and 2003) which contributed about 60% to the SSB. This represents a shift to the dominance of young fish from the survey in 2005. As in last years, the contribution of juveniles to the stock estimate is low; the survey may not give a good signal of expected recruitment. Results from the individual vessels are reported in more detail in respective survey reports (Shnar et al. 2006; Mullins et al. 2006; Heino et al. 2006; Jacobsen et al. 2006; Ybema et al. 2006).

International Survey	Abundance, 10 ⁹ individuals		Biomass, mill. tonnes		Mean weight g	Mean length cm
	total	spawning	total	spawning		
2005	90	83	8	7.6	88.6	26.3
2006	108	105	10.4	10.3	96.3	26.9

Use of this survey in blue whiting assessment:

While the time series is still very short (3 years), it would be advisable to incorporate also information from this survey in the assessment. This international survey and its Norwegian component provide complementary information on blue whiting spawning stock. Results from the Norwegian survey are needed to assess the development of the blue whiting spawning

stock before the conception of the international survey; only the time series from the Norwegian survey has been used in WGNPBW in tuning blue whiting assessment. However, the international survey provides better coverage and is therefore likely to be less affected by changes in distribution within the spawning area.

4.6.1.1 Norwegian survey on the spawning grounds

Background and status:

While from 2004 onwards this survey has been run as a part of the PGNAPES coordinated international survey (see 4.6.1 above), this survey has been run such that the integrity of the existing time series is maintained. The International blue whiting spawning stock survey is a new survey, and we still have little data to evaluate its performance. In comparison to the International Blue Whiting survey on the spawning grounds (which incorporates this survey), the results were very similar in 2004–2005 (differences in totals $\leq 6\%$). However, in 2006 the results diverged (differences in totals $\sim 20\%$): while the Norwegian survey indicated a marginal decrease in abundance, the international survey indicated a marked increase.

Results:

The highest concentrations were recorded in along the shelf edge from the Hebrides towards the Faroe Bank; the bulk of the biomass was distributed much more evenly than in 2005. Overall, the distribution pattern of blue whiting in the survey area can be considered as rather typical except for the low densities in the north. The estimated total abundance of blue whiting for the 2005 Norwegian survey was 8.2 million tonnes, representing an abundance of 92×10^9 individuals (Table 4.6.1.2). The stock estimate obtained in 2006 is marginally smaller than in 2005 but significantly smaller than in 2002–2004, both in terms of numbers and biomass (Table 4.6.1.3). As usual, the majority of fish were estimated to be mature, and the spawning stock is thus only little smaller than the total stock in the area. Year class 2002 (age 4 years) was the most abundant year class in the stock by a wide margin, and stronger than earlier surveys have indicated (Fig. 4.6.1.2). Together with year classes 2003 and 2001 (respectively ages 3 and 5 years), these year classes make 82% of the spawning stock. This is the first year since 2001 when the stock is not dominated by year class 2000. Its abundance is only 25% of the observed abundance in 2005, suggesting either very high mortality, low catchability of blue whiting this large, or both. Mean length and weight of blue whiting in the survey area are similar to the estimates from 2005 (Table 4.6.1.3); the increasing trend observed during the last five years has thus halted (see the text table above). Condition of blue whiting was somewhat better than in 2005 except for age class 1 year.

Use of this survey in blue whiting assessment:

Norwegian survey on the spawning grounds of blue whiting, west of the British Isles, provides the longest time series covering a significant part of the blue whiting stock, and thereby an important time series for tuning the assessment.

4.6.1.2 Russian surveys on the spawning grounds

Background and status:

The Russian research vessels surveyed the spawning stock since 1980. The area was firstly located between 57°N and 69°N, and the works conducted in April–May. Since 1984 area was shifted to 50°–62°N, and March–April become to be as new period. Mean area covered yearly in 1981–96 amounts 53 thousand miles². The vessels operated using pelagic and partly a bottom trawls with cod-end mesh 16 mm based on a distance of 30-miles between the latitudinal transects. After 1990 the surveys fulfilled in coordination with other research vessels.

Since 2004 the survey has been part of the coordinated international survey, and the results are included there.

Results:

In 2006 "Atlantnir" fulfilled the same work outside of EEZ zone from 54° to 59°30'N on 3–29.03 based on 15-miles distance between the transects. The total blue whiting biomass in the international waters was estimated as 2 million tones. This is two times more than in 2005. Mean temperature in the depth layer 400–600 m on Rockall was 9.64°C during the survey in 2005 and 9.85° C in 2006. The west directed transport of water predominated contributing the western migration of spawners.

Use of this survey in blue whiting assessment:

The time series are not used for the final assessment but only in exploratory runs (Table 4.6.1.4).

4.6.2 International ecosystem survey in the Norwegian Sea

Background and status:

The international ecosystem survey in the Nordic Seas is aimed at observing the pelagic ecosystem in the area, with particular focus on herring, blue whiting, mackerel (Norway), zooplankton and hydrography. In addition the Norwegian Sea was covered during July and August 2005 on a national basis. The observations on herring and blue whiting are done by acoustic observation with main focus on Norwegian spring-spawning herring (ASH) and blue whiting in the Norwegian Sea. The survey is carried out in May since 1995 by the Faroes, Iceland, Norway, and Russia, and since 1997 (except 2002 and 2003) also the EU. Estimates in 2000–2006 are available both for the total survey area and for the “standardized” survey area (between 8° W–20° E and north of 63° N). The latter is more meaningful as the survey coverage has been rather variable in the south where post-spawning blue whiting are entering the Norwegian Sea as well as in the west where large blue whiting occur. As these variations reflect non-biological factors that have nothing to do with migrations of blue whiting, the resulting noise is highly undesirable. The discussion below is therefore based on the estimate for the standard survey area.

Since 2005 this survey has extended into the Barents Sea where the main focus of investigations has been young herring and capelin larvae.

Results:

The total stock estimate in numbers is greatly reduced (by >50%) from the relatively stable level of 2003–2005. Reduction in the total biomass is somewhat less drastic (~26%) in comparison to 2005 but larger in comparison to earlier years. The change from 2005 is almost entirely due to very low abundance of age group 1 year — abundance (both in biomass and numbers) actually slightly increased for all the older age groups combined. In fact, age group 1 year is the smallest one on record, being by one order of magnitude weaker than the previous minimum. Reflecting the paucity of age group 1 year blue whiting, mean age in the stock reached a new record, 2.8 years (earlier range 1.3–2.1 years). The 2004 year class that was strong in 2005 appears now as being below average. Older age groups appear moderate in comparison to surveys in 2000–2005 (these year classes may not be representatively sampled in this survey as many individuals are not in the survey due to post-spawning migration). Distribution observed this years looks broadly similar to that observed in earlier years (Figure 4.6.2.1). Stock estimate for the total survey area is given in Table 4.6.2.1. Time series of stock estimates for the standard area are given in Table 4.6.2.2.

Use of this survey in blue whiting assessment:

The survey has been used in the final assessment from 2005 onwards. The performance of this survey in predicting recruitment is not yet well known, as the overlap with the assessment estimate is limited and the latter in general is plagued by uncertainties that reflect scarcity of data on the most recent year classes. However, the result is in line with the recruitment index from the Barents Sea where the index in 2006 was the lowest one since 1999.

4.6.3 Iceland acoustic summer survey

Background and status:

Iceland has carried out an acoustic survey in summer in the Icelandic EEZ since 1998. The last survey was carried out in 2004. It was then continued as a part of the international ecosystem survey in the Norwegian Sea (see above). Age-disaggregated results are available from 1999 onwards until and including 2004.

Results:

The survey in 2003 gave stock estimate that was well above the one from the previous years. However, this survey had a wider coverage than those before. This reflects wider distribution of blue whiting in the Icelandic waters. It can be argued that the increase reflects genuine increase of blue whiting in the area (see the discussion in Heino et al., WD 2004). Results from 2004 give nevertheless also an estimate that is calculated for the more restricted area covered all years. The survey in 2004 confirms the results from 2003 that year class 2003 is weak in Icelandic waters. Year class 2004 is average in strength. The mean age is the highest observed in this survey.

Use of this survey in blue whiting assessment:

The survey is not used in the assessment.

4.6.4 Norwegian Sea summer survey

Background and status:

In 1981–2001 Norway ran an acoustic survey in the Norwegian Sea in order to follow the migration of Norwegian spring spawning herring and to measure blue whiting in its feeding areas. This survey used to give the first indication of the incoming year class measured at age 1; in 2004 SGAMHBW recommended using indices from this survey at ages 1–4 years.

This survey was started anew in 2005, but with little focus on blue whiting. No estimates have made.

Results:

The stock estimates in numbers at age are given in Table 4.6.4.1.

Use of this survey in blue whiting assessment:

As the survey is terminated it provides little information for the latest years in the assessment, and it was decided not to use the survey in the final assessment.

4.6.5 Russian survey in the Barents Sea

Background and status:

A blue whiting stock survey was carried out in the Barents Sea and adjacent waters in October–December 2004. This is the continuation of survey series started in 2000 but was not carried out in 2005. Two vessels participated in the 2004 survey: “Smolensk” and “Fridtjof

Nansen". As the work mentioned was a part of multi-species trawl-acoustic survey, both bottom and pelagic trawls were applied to the schools identification. The area investigated makes 235 thousand square miles.

Results:

Estimated biomass of blue whiting over the whole surveyed area constituted 524 thousand tones whereas in 2003 only 350 thousand tones were found. Almost whole biomass was distributed in the ICES divisions IIa and IIb.

Use of this survey in blue whiting assessment:

The survey is not used in the assessment.

4.6.6 Spanish bottom trawl survey

Background and status:

Bottom trawl surveys have been conducted off the Galician (NW Spain) coast since 1980, following a stratified random sampling design and covering depths down to 500 m. The survey directed to a mixture of species. Since 1983, the area covered in the Spanish survey was extended to completely cover Spanish waters in Division VIIIc. A new stratification has been established since 1997.

Results:

Stratified mean catches and standard errors are shown in Table 4.6.6.1 . Larger mean catch rates are observed in the 100 - 500 m depth range. Since 1988 the highest catch rates in the Spanish survey were observed in 1999 (124 kg/haul). The 2005 estimate is 70 kg/haul. (Figure 4.6.6.1).

Use of this survey in blue whiting assessment:

The survey is not used in the assessments.

4.6.7 Portuguese bottom trawl survey

Background and status:

Bottom trawl surveys have been conducted off the Portuguese coast since 1979, following a stratified random sampling design and covering depths down to 500 m. The area covered in the Portuguese survey was extended in 1989 to the 750 m contour.

Results:

Stratified mean catches and standard errors from the Portuguese survey are shown in Table 4.6.7.1. Larger mean catch rates are observed in the 100 - 500 m depth range. No new information on this survey was available this year to the Working Group. The Portuguese autumn surveys generally give higher values than in the summer surveys, and a better correlation with the Spanish surveys (Figure 4.6.7.1).

Use of this survey in blue whiting assessment:

The survey is not used in the assessments

4.6.8 Faroes plateau spring bottom trawl survey

Background and status:

On the Faroe plateau an annual demersal bottom trawl surveys is carried out during spring (March 1996-2006). The survey is aimed at cod, haddock and saithe, but varying amounts of blue whiting are caught as by-catch each year.

Results:

The results from 2006 survey are not yet available. The earlier results are in Table 4.6.8.1.

Use of this survey in blue whiting assessment:

The survey is not used in the assessments

4.6.9 Icelandic bottom trawl survey - spring

Background and status:

The Icelandic Groundfish survey in March has been conducted annually since 1985. The survey covers the Icelandic continental shelf down to 400m. In the period 1985–1995 and since 2004 the Icelandic part of the Icelandic-Faeroes ridge was covered. The number of stations has been variable, or between 500 and 600. The survey is conducted by 4–5 trawlers identical trawlers, built in Japan in the nearly 1970's.

Results:

Blue whiting is caught in the survey near the edges of continental shelf in the southern part of the survey area. In recent years blue whiting has been found at 70–100 stations in the survey. Blue whiting was not measured regularly in the survey until 1996. The length distributions and age readings from the same month indicate that smaller than 21 cm fish can be considered a proxy of age 1 fish. The index of age 1 blue whiting is calculated as the mean number of age 1 per station in the area covered by the survey in all years.

The number of age 1 blue whiting in the Icelandic groundfish survey in 2006 was the highest on record (Table 4.6.9.1). The highest number before were in 2002 and 2003 but year classes 2001 and 2002 were both relatively strong in Icelandic waters. In 2006 age 1 blue whiting was only caught in a limited area off the south coast while in 2002 and 2003 age 1 blue whiting was found from the central south coast to the north west coast.

Use of this survey in blue whiting assessment:

The survey is not used in the assessment.

4.6.10 Icelandic deep water shrimp survey

Background and status:

The Icelandic deep water shrimp survey has been conducted in July - August since 1987. The survey covers the deep waters (> 200m depth) north and east of Iceland and the number of stations has been around 180.

Results:

From 1987–1997 blue whiting was only found at 0–5 stations, 3-25 in 1998–2002 but 144 in 2003. The total number of blue whiting in 2003 was also 1000 times larger than in any year 1987–2002. Since 2003 the number of blue whiting has reduced much but is large compared to earlier period.

Use of this survey in blue whiting assessment:

The survey is not used in the assessment.

4.6.11 Icelandic bottom trawl survey - autumn

Background and status:

The Icelandic groundfish survey in autumn commenced in 1996. The survey covers the Icelandic continental shelf down to approximately 1000 m depth but the number of stations is smaller than in the March survey. The survey is conducted by two research vessels.

Results:

Catch of blue whiting in the autumn survey is considerably more than in the March survey, both due to seasonal effects, gear and higher proportion of the stations in areas where blue whiting is found. Stomach samples taken from cod and saithe in the autumn survey do also confirm importance of blue whiting as prey of those species. In autumn length distribution of age 1 blue whiting overlaps with other age groups too much for separation of this age group by length measurements only.

Use of this survey in blue whiting assessment:

The survey is not used in the assessment.

4.6.12 Faroes plateau autumn bottom trawl survey

Background and status:

On the Faroe plateau an annual demersal bottom trawl survey is carried out in autumn (August–September 1994–2005). The survey is aimed at cod, haddock and saithe, but varying amounts of blue whiting are caught as by-catch each year.

Results:

No updated results exist. Earlier results are shown in Table 4.6.12.1 and Figure 4.6.12.1.

Use of this survey in blue whiting assessment:

The survey is not used in the assessments.

4.6.13 Norwegian shrimp survey in the North Sea

Background and status:

Norway has conducted a bottom trawl survey on shrimp in the northern parts of the North Sea annually in October 1984–2002 (Tveite 2000). Blue whiting is caught in >95% of trawl hauls, with individual lengths ranging between 9 and 52 cm. Blue whiting have not been aged, but based on sampling of the commercial catches in the area by Norway, a reasonably good separation of 0-group blue whiting can be achieved by assuming that all individuals less than 19 cm in body length are of age 0 years. Separation of other age groups has not been attempted.

Results:

The results are summarized in Table 6.4.2.6 of the WG report from 2004, showing that 0-group blue whiting are occasionally very abundant, but that the years of great abundance show only weak correspondence with large year classes seen in the analytic assessment. This applies in particular to the recent strong year classes that have not occurred in large numbers in the North Sea.

Use of this survey in blue whiting assessment:

The survey is not used in the assessments.

4.6.14 Norwegian bottom trawl survey in the Barents Sea

Background and status:

Norway has conducted bottom trawl surveys targeting cod and other demersal fish in the Barents Sea since late 1970s. From 1981 onwards there have been systematically designed surveys carried out during the winter months (usually late January–early March) by at least two Norwegian vessels; in some years the survey has been conducted in co-operation with Russia. Blue whiting is a regular by-catch species in these surveys, and is in some years one of the most abundant species (Heino et al. ms).

Results:

Most of the blue whiting catches (or samples thereof) have been measured for body length, but very few age readings are available (from 2004 onwards otoliths are systematically collected). The existing age readings suggest that virtually all blue whiting less than 18 cm in length belong to 1-group and that while some 1-group blue whiting are larger, the resulting underestimation is not very large. An abundance index of all blue whiting and putative 1-group blue whiting from 1981 onwards is given in Table 4.6.14.1 and follows methods described in Heino et al. (2003) except that all blue whiting <18 cm in length are taken as 1-group blue whiting (threshold of 21 cm was used in 2004, 20cm in 2005).

1-group indices for both 2004 and 2005 are relatively high, while the index for 2006 was fairly low. The total indices are still at a historically high level.

Use of this survey in blue whiting assessment:

The survey is not used in the assessments.

4.6.15 Russian egg survey

Background and status:

Ichthyoplankton samples were collected during the spring cruise of R/V "Atlantniro" in 2006. The equipment and area investigated were as in the case of 2005 survey. 27 samples were

fixed and treated. Only 2 samples were empty. Stage V of egg development predominated in the samples (Table 4.6.15.1). Following the traditional approach (Hensen, 1887; English, 1964) the data on the duration of spawning period and on the incubation time were used to convert egg number to the SSB.

Results:

SSB was estimated as 4 million tonnes, what is four times more than in the last year. More dense egg distribution is as a reason of it (Figure 4.6.15.1). Only 12 statistical rectangles were visited at this survey while the international spring acoustic survey covers 57 ones.

Use of this survey in blue whiting assessment:

The present times series of only two years is believed too short to use for tuning of the assessment. Also the number of samples does not allow this data to be used for the assessment.

4.7 Stock assessment

The catch at age data were explored using a number of assessment tools. Apart from catch curve analyses, exploratory assessments were carried out using AMCI, ICA, ISVPA, SMS and XSA. The same set of tuning data were used in most final assessments.

4.7.1 Evaluation of data underlying the assessment

Catches

Figure 4.7.1.1 shows the number of blue whiting caught plotted on log scale and curves corresponding to $Z = 0.6$ drawn for comparison. The picture seems to indicate that year classes 1995 and 1996 have been disappearing from the catches at a rate corresponding to Z higher than 0.6 (around 0.7) but year class 1997 at a rate around 0.6. This interpretation of the graphs is dependent on the fishing effort being reasonably constant in recent years but gradually increasing fishing effort makes the slopes lower than the real value of Z . The catch curves also indicated that the smaller year classes may be exploited at a slightly lower rate. The curves are on the other hand difficult to interpret for age groups that have not been fully recruited to the fishery for more than 2 years, which applies to most of the age groups that are relevant today.

Surveys

Norwegian spawning stock survey in March–April

Figure 4.7.1.2 shows the internal consistency of the survey by comparing the abundance indices of a year class in the survey to the abundance indices of the same year class the year before. The consistency is best between age 3 and 4 but deteriorates after that, most likely due to increasing fishing mortality which is variable through the period. For the oldest ages sampling in the survey is most likely a problem. Only a small part of each year class is mature at age 2. This part is variable from year to year leading to variability in the indices for age 2 which are therefore not as good indicators of stock size as the abundance indices of older fish.

Looking at the 2006 survey figure 4.7.1.2 indicates that much more was found of year class 2002 than expected from the results of the 2005 survey. In 2005 this year class was on the other hand less abundant than it should have been according to the 2004 survey. The figure also indicates that in the 2006 survey year classes 1998–2000 were less abundant than would have been expected from the results of the 2005 survey. These findings could indicate sampling problem in the 2006 survey or possibly a high fishing effort towards the old fish in 2005.

Figure 4.7.1.3 shows log of the abundance indices from the Norwegian survey on the spawning grounds in February. According to the figures the year classes 1998 and 1999 have been disappearing at a rate corresponding to $Z = 0.6$, but year class 1996 at higher rate of approximately $Z = 0.7$. The figure also indicates that the indices of year classes 1998–2000 reduced rather much between the 2005 and 2006 surveys as also could be seen from figure 4.7.1.2.

Figure 4.7.1.2 indicates that the use of indices for age 2 from the spawning fish acoustic survey might be questionable and the survey does not at all cover age 1.

International ecosystem survey in the Norwegian sea in May

This survey is covering a large part of the immature part of the stock and might therefore give better indices of recruitment. The survey is on the other hand not considered as an reliable indicator of the mature part of the stock which migrates much more than the immature part.

Figure 4.7.1.4 shows that the internal consistency of the May survey is reasonably good but there are some exceptions like for year class 2001 between ages 1 and 2 and the 1996 year class between ages 4 and 5. As discussed in section 4.8 the Icelandic acoustic survey in July indicates that the 2001 year class was unusually abundant at age 1 in Icelandic waters that were not covered by the May survey at time.

The figures as tables from the May survey do also indicate that the abundance indices decrease rapidly with age.

4.7.2 Data exploration with AMCI

Explorations were carried out with the latest version of AMCI, version 2.4. The version carries the same version number but contains some updates (only one related to runs with 2 catch fleets is of significance here). Repeating the final AMCI assessment from 2005 with the new version of AMCI yielded essentially identical results.

The final WG assessment from 2005 updated with the new data available (catch in 2005 and Norwegian spawning stock and Norwegian Sea ecosystem surveys in 2006) and with recruitment estimated shows an overall increase in SSB (and a corresponding decrease in F) since about year 2000 in comparison to the 2004–2005 assessments (Figure 4.7.2.1). Recruitment estimates from about year 1999 onwards are also slightly increased. However, the overall patterns remain very similar.

The SPALY run with the exception of recruitment in the terminal year being estimated was presented as the final AMCI run and is shown in Figure 4.7.7.1 and Table 4.7.2.1. The data sources and main settings of the final AMCI run are as follows:

- Catch at age, ages 1–10+ years, age 1 year down-weighted (weight 0.5)
- Norwegian spawning stock survey, index at ages 3–8 years
- International Norwegian Sea ecosystem survey, index at ages 3–8 years
- Objective function: squared log residuals for numbers at age from catch and 2 survey fleets with weight 1 each, and landings with weight 2
- For fishery, uniform selection for ages 6–10 years and one “separable” period but gain factor 0.5 for age 1 year and 0.1 for ages 2–5 years to allow for small changes
- For both surveys, age-specific selectivity and one separable period

Model residuals are shown in Figure 4.7.2.2. Retrospective analysis is illustrated in Figure 4.7.2.3 and the results from bootstrapping catches and survey time series in Figure 4.7.2.4 and Figure 4.7.2.5. Furthermore, the results turned out to be rather robust with respect to changes in relative weighting of different ages in the catch and survey data.

The residuals show no worrisome features, and the retrospective analysis suggests that the assessment is not prone to bias. As always, there is increasing uncertainty towards the end of the assessment period. Bootstrapping suggests that a range of combinations of F in the final year and SSB in the end of the final year ranging from low F and high SSB to high F and low SSB are possible given the uncertainty in the data. Among other things, the uncertainty in recruitment in 2001 (the strongest year class in record) is manifested in the estimate of SSB in the end of the final year.

The assessment turned out to be somewhat sensitive to the recruitment estimation in the terminal year. The estimated value in 2006 is based on just one data point (Norwegian Sea ecosystem survey, age 1 year). If a “bad” guess is made in the sense that it is higher than one suggested by the survey, the assessment in recent years is shifted upwards in terms of stock numbers. This consequence of a badly specified model (the value should have been weighted down but was not). This is the main reason for change between 2005 and 2006 assessments (retrospective run shows only small changes).

The actual level of stock in the recent years is somewhat sensitive to the choice of input data, whereas the pattern of change is robust. Thus, if age 2 years in the Norwegian spawning stock survey is included in tuning, SSB in 2006 is about 0.7 million tonnes less than in the basic run. If the international spawning stock survey (ages 3–8 years) is taken as an additional tuning series, SSB in 2006 is about 1.3 million tonnes less than in the basic run. The difference is similar if the international spawning stock survey is used instead of the Norwegian one.

Changes in the fisheries suggests that exploitation pattern has varied in the recent years. A large component is due to directed Norwegian fishery in southern Norwegian Sea (Area IIa) that was in operation mainly in 2001–2004. Mostly juvenile blue whiting were caught in this area. This fishery partially overlaps with the mixed industrial fishery in areas IIa, III and IVa, which similarly catches more juveniles than the spawner fishery.

Exploratory runs trying to separate these fishery components are a separate catch fleet was done in order to evaluate the consequences of violating the separability assumption made in most statistical catch at age models (strictly so in SMS and ICA and in some versions of ISVPA, while AMCI allows modest flexibility). Unfortunately data are readily available to do so is only available from year 2000 onwards. The directed fishery in IIa started essentially afresh in 2001 and this is not a problem. However, sampling from this fishery was not very good. Industrial mixed fishery is an old fishery component and starting it from 2000 is somewhat artificial. Sampling from this fishery has been of more even quality.

Figure 4.7.2.6 shows an example of a two fleet assessment. Separation of the fleets brings mostly expected results: recruitment from 2001 onwards is estimated lower. SSB in 2006 is about 1.2 million tonnes. However, recruitment in 1998 is for some reason not well estimated and results in some cohort effects. Also total landings significantly deviate from the observed ones in recent years. All in all, two fleet assessments would still require more effort to get a satisfactory fit, but even at their present state illustrate some likely problems in one fleet assessments that are caused by the changes in selection pattern.

4.7.3 Data exploration with ISVPA

This year a new, “triple-separable”, version of the ISVPA model (TISVPA) was used for exploratory runs. This version allows to take into account possible cohort-dependent peculiarities in selection pattern originating from possibly different interaction of different cohorts with fishing fleet, or by possible errors in aging of some cohort or by some other unrevealed reasons. For details of the TISVPA model see (Vasilyev, WP##). The so called mixed version of the model was used (giving equal weights to assumptions that catch-at-age data are true and that selection pattern is stable). Other settings of the model were the following: unbiased separable representation of fishing mortalities and single selection pattern

for the whole period. Three age-structured survey data were used: Norway spawning acoustic (1991–2006); Norway Sea May acoustic (2000–2006), and March international acoustic (2004–2006).

Norway Sea May acoustic survey data (survey 2) gave minimum only if they were used as indices of proportions, not of abundance. q are estimated for all surveys. Profiles of respective components of the loss function age given on Figure 4.7.3.1. Total loss function was composed as a weighted sum of respective components. The weights of the components bringing the values of each component to the same scale were used. As it can be seen from Figure 4.7.3.1, minima from all sources of data correspond to similar values of the effort factor in terminal year, except for Norway spawning acoustic surveys, indicating somewhat lower value of terminal fishing mortality.

Residuals for all sources of information are presented on Figure 4.7.3.2. As it can be seen by comparison of Figures 4.7.3.2 and 4.7.3.3, incorporation of the generation- dependent factors into separable representation of fishing mortality helps to exclude cohort pattern in catch-at-age residuals existing in the results of the “ordinary” ISVPA, which residuals are given on Figure 4.7.3.3.

Figure 4.7.3.4 represents the TISVPA-derived estimates of selection pattern, where generation-dependent factors are taken into account.

Comparison of theoretical catches with reported values for ages 1-10 are presented on Figure 4.7.3.5. Main discrepancy is in 2001-2002, what may indicate underreported catches in 2001 (real decrease in the world catches in 2001 seems not very reasonable bearing in mind gradually developing blue whiting fishery in those years).

Results of retrospective runs are shown on Figure 4.7.3.6.

The results of blue whiting stock assessment by means of TISVPA are summarized on Figure 4.7.3.7 and in Tables 4.7.3.1- 4.7.3.3.

Bootstrap estimates of uncertainty in the results are presented on Figure 4.7.3.8.

As a result of analysis of preliminary assessments made by other models at this meeting, it was decided by the Working Group to exclude survey 3 and age 2 from survey 1 from analysis. While there were no signs in TISVPA residuals that age 2 in survey 1 is specific (see Figure 4.7.3.2) and survey 3 gave good signal about the stock which was inline with other sourced of information (see Figure 4.7.3.1), an additional TISVPA run with restricted survey data was made. Its result is rather similar to was obtained using the whole data. Figure 4.7.3.9 compares the results for restricted data set obtained using TISVPA and “traditional” ISVPA, as well as the TISVPA-derived result for the whole survey data set, to the results of previous blue whiting assessment by means of ISVPA. They are in line.

Results for this additional run are given in Tables 4.7.3.4-4.7.3.6.

Reference

Vasilyev D. WP##. Year class peculiarities in selection pattern: how stock assessment based on separable cohort models is able to take them into account? (Some illustrations for triple-separable case of the ISVPA model - TISVPA).

4.7.4 Data exploration with ICA

The ICA (Integrated Catch At Age Analysis) model was used to explore blue whiting data using a number of different scenarios in order to obtain the best fit to the model. The analysis planned to investigate the effect of:

- The different tuning fleets on model fit and stability

- Removal of ages from the tuning fleet
- Varying the separable period
- Different levels of selection (S) on the last age
- Iterative or manual down weighting

In previous years additional ICA settings have been investigated such as the reference age for separable constraint. The reference age three was chosen as this is considered to be the first fully recruited age in the fishery. This was used in all of the 2006 runs.

Initial exploratory runs used the same procedure as last year (SPALY), with updated data. The final run in 2005 used the Norwegian spawning stock survey from 1991 - present, with ages 2–8, as a tuning series. This was the starting point for the 2006 explorations. Some of the exploratory runs carried out in ICA are shown in Table 4.7.4.1.

Choice of iterative down weighting was investigated and was found to have no impact on recruitment, SSB or mean F. In subsequent runs manual down weighting was chosen. Varying the separable period was examined by reducing the period from 8 years to 6 years and 4 years. This produced the same type of recruitment pattern but a higher SSB and mean F. When the separable period was reduced, deterioration in the model fit was evident. Examination of the residual pattern showed that a longer period improved the pattern. Changing the selection in the last year produced similar results with increased SSB and lower mean F. Again there was no improvement in the model fit. It was decided to keep the same ICA settings as last year for further runs.

The use of different tuning fleets was examined. Firstly the use of the International acoustic survey was investigated. The time series currently runs from 2004–2006. Including this survey did not have a discernible effect on the output from ICA. It was decided by the group not to use this survey as a tuning fleet until a longer time series becomes available.

In order to be consistent with other models the same two tuning fleets were used. The Norwegian spawning stock survey from 1991 – 2006, ages 3-8 and the Norwegian Sea ecosystem survey, from 2000 – 2006, ages 1 and 2. The comparison between run 1 (spaly) and the final runs in 2005 and 2006 are shown in Figure 4.7.4.1. The use of an additional survey to tune the assessment, gives higher levels of recruitment, SSB and a lower mean F. The ecosystem survey carried out in May is the main index of recruitment currently used by the working group. The decision to remove age 2 from the Norwegian spawning stock survey was taken because two years olds are not fully recruited and this survey displays variability in the indices for this age. Excluding age 2 from the assessment improves the model fit. Residual patterns are shown in Figure 4.7.4.3.

Overall run 7 offers a good level of consistency with the previous years assessments. This run used age 3 as the reference age with an 8 year separable period and age 1 fish were down weighted by 50%. Taking this as the final ICA run shows that SSB continues at a high level. Recruitment is at a higher level than last year and is showing an increase. Mean F appears to be decreasing. When compared to other models, SMS, AMCI and ISVPA, ICA produces higher values for recruitment and SSB and a lower mean F in the final year. The stock summary, predicted catch, fishing mortalities and population abundance from the final run are presented in Tables 4.7.4.2–4.7.2.5.

Diagnostics from the final ICA run are shown in Figure 4.7.4.2. The SSQ surface plot shows that one well defined minimum is reached. The standard plots for landings, fishing mortality, recruitment and stock size are also presented. It is not clear why the stock size graph shows a decline in the final year.

Retrospective analysis (Figure 4.7.4.4) illustrates that the ICA assessment has been developing consistency over the last five years. The uncertainty increases towards the end of

the assessment period, as is expected. Overall, the retrospective pattern shows a relatively stable assessment over time.

Settings used for ICA final run	2005	2006
Number of age structured tuning series	1	2
Number of biomass tuning series	0	0
Number of years for separable constraint	8	8
Reference age for separable constraint	3	3
Constant exploitation pattern	Yes	Yes
S to be fixed on last age	1.5	1.5
Age range for mean F	3-7	3-7
Catchability model for tuning fleets	Linear	Linear
Age range for the analysis	1-10	1-10
Survey weights for all fleets	100%	100%
Shrinkage	No	No
Manual down weighting	Yes	Yes
Tuning series split	Yes	No
Weighting of age 1 catch numbers	50%	50%

4.7.5 Data exploration with SMS

SMS (Stochastic Multi Species model) (Lewy and Vinther, 2004) is an age structured assessment model to handle biological interaction, however, it can be reduced to operate with one species only. In "single species mode" an objective functions for catch at age numbers and survey indices at age time series are minimized assuming a log-normal error distribution for both data sources. The expected catch is calculated from the catch equation and F at age, which is assumed to be separable into an age selection and a year effect. SMS uses maximum likelihood to weight the various data sources.

SPALY run

A SMS was made using the same settings as last year and updated data series. The results are presented on Figure 4.7.5.1 together with the final SMS assessment from the two previous years. Results are discussed later in this section.

Tuning data

After initial exploratory runs the WG decided to use the two surveys presented below together with the SMS specific options for catchability and variance.

Survey	Year range	Catchability at age	Variance at age of survey observation
Norwegian Acoustic survey on spawning grounds	1991-2006	By age-group: age 3-6. Combined: age 7-8	Combined: 3-5 and 6-8
Norwegian Sea, May	2000-2006	By age-group: age 1-2.	By age: 1-2

Compared to the SMS SPALY run, the Norwegian Acoustic survey, 1981-1990, are now excluded and the minimum age group for the same survey for the period since 1991 is now raised from age 2 to age 3.

Catch data

Catch data for the period 1981–2005, age 1 to age 10+ were used. The age selection pattern was assumed constant within two periods, 1981-1992 and 1993-2005. Selection at age was estimated by individual age group for age 1 to 7 and combined for age 8-10.

Two settings for the variance of catch at age observation were applied:

- 1) estimated separately for age 1, age 2, age 3-6 combined and age 7-10 combined. A lower bound on CV at 25% was applied
- 2) As 1) but without constraint on catch at age CV

Diagnostics, explorative runs

The effect of an unbounded CV on catch observation is shown in table 4.7.5.1. The log likelihoods from the two configurations show a better fit of catch data for the unbounded CV configuration, and similar likelihoods for the survey observation. The unbounded version has lower CV for ages up to age 7 and a higher CV for the older ages. The residual plot for the two runs (Figure 4.7.5.2-4.7.5.3) show the same results with the smallest residuals for the youngest ages in the unbounded configurations.

The effect of an unbound CV is a lower CV on the most abundant caught age groups. This is expected as these age groups have the highest sampling levels which lead to lower uncertainty.

The comparisons of runs (Figure 4.7.5.1) shows that the unbounded CV configuration gives a higher F, a lower SSB and a lower recruitment in the terminal year, but the difference between the two configurations is not big.. The SPALY run gives the same SSB and lower F compared with the unbounded CV configuration.

Final SMS configuration

The configuration with unbound CV was chosen as the final SMS assessment as the effect of unbounded catch observations was as expected and there is no obvious reason for down weighting the most numerous caught age groups.

The SMS diagnostics (Table 4.7.5.2) show that the log-likelihood contributions are highest from catch data. This is also reflected in the lower CV of catch observation (in the range 0.17-0.51) compared to the CV of survey observation in the range of 0.41-0.61. Survey catchability at age from the spawning area survey are fairly constant over age, however with age 4 as an outlier. The Norwegian Sea May survey for juvenile shows the highest catchability for the 1-group.

The estimated exploitation patterns (Figure 4.7.5.4) for the two periods, 1981-1992 and 1993-2005, are fairly similar, however with a shift towards age 3-5 in the most recent period.

There is no consistent pattern in the residuals plot for catch observations (Figure 4.7.5.3), which indicates that the assumption of a separable F is not severely violated. The residual pattern for the Spawning ground survey (Figure 4.7.5.5), has no pronounced cohort effect, but shows a clear year effect for some years, as often seen in acoustic surveys. The time series for the May, Norwegian Sea survey is rather short and shows no clear pattern in the residuals.

Observed and model yield are fairly overlapping (Figure 4.7.5.6), however with some discrepancy for the years 1999-2002.

Due to the very short “Norwegian Sea, May 2000-2006” survey the retrospective analysis was done only for 2002-2005 (Figure 4.7.5.7). There is a tendency for overestimation of F and underestimation of SSB. Recruitment estimates are relatively stable without a trend.

SMS uses maximum likelihood to estimate the parameters and puts as default an equal *a priori* weighting factor (=1.0) on all observations (catch at age and survey CPUE at age information). To investigate the sensitivity of this default settings, different *a priori* weights were applied to the survey observations ranging from a low weight (weighting factor 0.1) to a high weighting factor (3.0). Weighting on catch observation was kept constant at 1.0. The results (Figure 4.7.5.8) show that the estimated SSB are sensitive to the *a priori* weighting factors on surveys. That shows that the overall signal in the two data sources, catch and

survey, is the same, however the details differ slightly. From Figure 4.7.5.8, it is clear that an increasing *a priori* weight on survey observations gives an increase in the estimated SSB in the terminal year. Said in another way, survey observations indicate a higher SSB than the catch data.

Results

Estimated fishing mortalities are presented in Table 4.7.5.3, stock numbers in Table 4.7.5.4, stock summary in Table 4.7.5.5 and Figure 4.7.5.9 and stock recruit plot in Figure 4.7.5.10.

The uncertainty of estimated of SSB, F and stock numbers 1. Jan 2005 and 2006 are presented in Figure 4.7.5.11. For 1. Jan 2005 a CV at 36% for the estimated 1-group stock number and 22% CV for the 2-group emphasize that rather little is known about the abundance of the recruiting ages to the fishery. For the terminal year the CV of the estimated SSB is 13% and 17% for mean F. Compared to last year's SMS assessment, the uncertainty of F is reduced, probably due to the unbounded uncertainties on catch observations this year.

The uncertainties presented above have been calculated from the Hessian matrix. Assessment uncertainties estimated by the use of Markov Chain Monte Carlo (MCMC) simulations, with 200 000 chains thinned by a factor 500, is presented on Figure 4.7.5.12

4.7.6 Data exploration with XSA

The data were explored with a number of different scenarios in order to obtain the best model fit. Explorations began with investigations of the effect of different tuning fleets on the model fit and stability. The following sources of data were used:

- Norwegian spawning stock survey (NSSS) 1981- 2005
- Russian spawning stock survey 1982-1996
- Norwegian Sea ecosystem survey 1989-2001

In exploring the contribution of the different tuning fleets, the NSSS was defined as the principal one and is responsible for the main trends in the log catch residuals. After splitting the NSSS into two sets (1981-1995 and 1986-2005) four fleets were used. As result the number of years with year-effects decreased. The levels of log-catch residuals were reduced also (Table 4.7.6.1). Taking account of that diagnostic it was considered that the appropriate configuration for the final run should be as follows:

- q plateau set at age 6
- catchability depend on stock size for ages less than 3
- SE at survey estimates set as 0.3
- regression type P

The results of these runs are presented in Table 4.7.6.2 and Figures 4.7.6.1 - 4.7.6.2. Results of the retrospective analysis seem to be steady.

The shape of the curves obtained for F, SSB and recruitment at age are similar to those from other models.

Using the number of survivors at the end of 2005, mean recruitment and mean weights by ages, the SSB at the start of 2006 is estimated to be 98% of the 2005 level.

4.7.7 Comparison of results of different assessments

The results of the preferred assessments, carried out with each assessment model (AMCI, ICA, ISVPA, SMS and XSA), are compared in Figure 4.7.7.1. The different assessments give basically similar results as last year with the exception of the most recent years. In general the results of the models are in good agreement with each other. The models AMCI, ICA, ISVPA and SMS use the assumption of separability, whereas XSA is a VPA-type of assessment model. Differences between the results may to a large extent originate from the differences in how external data sources are used in the assessment or the capability of the model to use certain kind of data. Also different weighting of the various input sources (example: see Figure 4.7.5.8) may have contributed to differences in the results.

SSB: All models show a similar historical development of the SSB. They indicate a significant increase in SSB in the late 1990's to a historic high in 2003. The assessment made by XSA is though a level lower than the others during that time. At its maximum size the stock is estimated by the different models between 4.6 and 7.0 million t. Most models indicate that SSB has declined since 2003, but at a different rate is seen in different models. The high SSB estimates are in line with the results from the acoustic survey on the spawning grounds although there is a difference in trend between the survey and the assessments in 2001-2003. The decline in SSB in 2005 indicated by the assessment corresponds to the survey, but the decline from the year 2005 to 2006 is not seen in the spawning stock surveys. The spawning stock in 2006 is estimated between 3.3 and 5.9 million t.

Fishing mortality: Trends in fishing mortality estimated by the different models show the same trend but are noisier than SSB estimates. All models indicate a sharp decrease in F from 1990 to 1991. The reasons for this decrease are unclear and may reflect a data problem or a shift in the fishery to other components of the stock. Also, all models indicate F has increased after 1994. Between 2000 and 2003 trends in F become unclear, with perhaps a very slight decline. In 2004, F is estimated to increase by all assessments and is very high in the ISVPA assessment. In 2005, F decreases in all assessments but is still very high and is above F_{pa} in all assessments and even above F_{lim} in ISVPA.

Recruitment: All models indicate a significant increase in the level of recruitment after 1995. The estimate of the 1996 year class is almost the same by all models and is estimated as a strong year class. The 2000 year class was estimated as the strongest in the time series by all models. From 2003 onwards the estimates start to deviate: The estimate of recruitment in 2003 estimated by ICA is higher than for the other models, and in 2004 the recruitment estimate by ISVPA and ICA are very low, and the range of the estimates is huge. The recruitment in 2006 (year class 2005) is not estimated well by any model or has been assumed. Recruitment for this year will be estimated separately.

Catches: All the separable models estimate catches in those periods where separability of the fishing pattern has been assumed. Figure 4.7.7.1. shows that there is in general good agreement between observed and modelled catches in the historical period. ISVPA shows a noticeable discrepancy between observed and modelled catches in 2002 and in some earlier years. At large the other models follow the trend in the catches.

The WG had to choose results from one assessment method to bring forward as basis for the predictions. The SMS method showed most consistency of the models both between years and in retrospective pattern. As it was also used to evaluate the management plan it was decided to use SMS as the assessment tool this year.

4.7.8 Final assessment

The key settings and data for the final blue whiting assessment in 2006 are shown in the table below. The key settings of the final assessment in 2003–2005 are also shown for comparison¹. Some of the settings are described in more detail after the table.

Settings/options for the final assessment	2003	2004	2005	2006
Software	AMCI 2.2	AMCI 2.3a	SMS	SMS
Age range for the analysis	1-10+	1-10+	1-10+	1-10+
Last age a plus-group?	Yes	Yes	Yes	Yes
Age at recruitment (from Jan 1 in the year of spawning)	1	1	1	1
Recruitment in the terminal year	Fixed	Fixed	Estimated	Estimated
Recruitment in the terminal year-1	Fixed	Estimated	Estimated	Estimated
<i>Catch data</i>				
Lower bound of CV on catch observation	n.a.	n.a	0.25	0
Constant selection pattern for the catch fleet?	Almost	Almost	2 periods	2 periods
First age with age independent selectivity	8	8	8	8
<i>Age-structured tuning time series</i>				
<i>Norwegian acoustic survey on the spawning grounds, ages 2-8</i>	1981-2003	1981-2004	1981-2005	1991-2006
Age range	2-8	2-8	2-8	3-8
First age with age independent catchability	6	6	7	7
<i>Russian acoustic survey on the spawning grounds, ages 3-8,</i>	1982-1996	1982-1996	not used	not used
<i>Norwegian Sea summer acoustic survey, ages 1-7</i>	1981-2001	1981-2001	not used	not used
<i>Norwegian Sea international ecosystem survey, ages 1-2</i>	not used	not used	2000-2005	2000-2006
Age range	1-2	1-2	1-2	1-2
First age with age independent catchability	2	2	2	2

Input data are catch at age numbers (Table 4.5.4.7), mean weight at age in the sea and in the catch (Table 4.5.5.1) proportion mature at age (Table 4.5.7.1). Natural mortality, 0.2, is assumed constant for all ages and years.

Survey data used in tuning are shown in Table 4.7.8.1, the Norwegian acoustic survey on the spawning grounds is split into two time periods reflecting a likely change in catchability caused by a change in acoustic equipment (from Simrad EK-400 to EK-500). This year, only the period using EK-500 is used. The age range has been changed from 2-8 to 3-8. Survey indices are treated as relative abundance indices.

Recruitment in 2005 was estimated from the assessment.

The model was run until 2005. The SSB January 1st in 2006 is estimated from survivors without taking the contribution from recruits into account. 11% of age group 1 is assumed mature and applying the same recruitment estimates as used for forecast the SSB in 2006 will increase by 1.7%. The key results are presented in Tables 4.7.5.3–4.7.5.5 and summarized in Figure 4.7.5.9. Residuals of the model fit are shown in Figure 4.7.5.3 and Figure 4.7.5.5.

¹ The main difference is the time series of assessment is the shift from the AMCI model to the SMS model in 2005. Both methods model the catch from the catch equation and F at age, which is assumed to be separable into a year and an age selection. In SMS the age selection is fixed for a range of years, while AMCI allows a gradually change in age selection from year to year. AMCI split the annual input catches at age into quarterly catches from an input key applied for all years, while SMS operates with annual catches and assumes that fishing mortality is constant over the year. Both models use survey indices at age, which are related to the stock number through an age dependent catchability parameter. Both models assume a log-normal error distribution for catch and survey data. SMS uses the Maximum likelihood method to estimated parameters and give the same *a priori* weight to all observations (catch at age and survey CPUE). AMCI has no explicit use of variance estimates in the objective function, but uses input weighting factors for the various types of observations.

Some modest cohort effects are visible in the catch residuals for the early cohorts. Year effects occur throughout the spawning stock survey time series.

The assessment key results (Tables 4.7.5.5, Figure 4.7.5.9) indicates that fishing mortality first steadily increased since mid-1990s and has then been fluctuating in the upper part of the range between F_{pa} and F_{lim} . The exploitation pattern (Figure 4.7.5.4) indicates only a modest change between the two periods. SSB has been increasing since 1990 to the highest observed level in 2003, after which SSB has declined. Year class 2000 (recruits in 2001) is the highest in the time series by a large margin. All year classes 1995-2004 are strong in comparison to recruitment before 1995; even the weakest year class born after 1996, that of 1998, is much stronger than was typical before 1995.

Retrospective analysis (Figure 4.7.5.7) shows a small but consistent bias towards under-estimation of SSB and over-estimation of fishing mortality.

Markov Chain Monte Carlo (MCMC) simulations (Figure 4.7.5.12) give an indication of the uncertainty in the assessment. The 95 % confidence intervals for SSB in 2005 are wide but do not overlap with B_{pa} , whereas fishing mortality in 2005 is with >95 % probability larger than F_{pa} , with modal F close to F_{lim} .

4.8 Recruitment estimates

Information on recruitment (age 1 year) in particular and young blue whiting (ages 0-2 years) in general is provided by a number of surveys, none of these covering the whole distribution of juvenile blue whiting. Only one of these, international Norwegian Sea ecosystem survey in May, is used in the current assessment. The shortcoming of this time series is its shortness, a problem that applies to most other time series as well. Here we discuss this and other surveys from the viewpoint of recruitment in the latest years.

Figure 4.8.1 shows an overview of normalized survey time series in the northern areas (the Faroes and northwards). Information on age 0 is scanty (only two time series, none of extend to the present) and does not provide a consistent signal. Similarly, at age 2 years the data are scanty but suggest a decreasing trend.

Information on age 1 year (age at recruitment used in the assessment) is provided by several surveys. These all tend to suggest that recruitment in all years between 2000–2005 has been close to (2002–2003) or above (2000–2001, 2004–2005) average of the respective time series. The outlook for recruitment in 2006 is different. Two indices that have earlier provided good indications on year class strength, Norwegian Sea ecosystem survey and Barents Sea winter survey, are below average (the former is record low – but recall that the time series is only seven years). On the other hand, Icelandic spring demersal survey is at its historic high.

Norwegian Sea survey covers, according to current knowledge, the main nursery areas of blue whiting, whereas Barents Sea and Icelandic demersal surveys cover somewhat marginal areas. In the standard area of the Norwegian Sea ecosystem survey, the numbers of recruits were exceptionally low. At the same time, the opposite is true for the Icelandic survey. It is therefore possible that a large proportion of recruits were distributed outside the standard survey area. However, even if all the survey area is included (covering the Icelandic waters where juvenile blue whiting occur), the estimate is still low.

Figure 4.8.2 presents predicted recruitment up to year class 2005 based on four survey time series. Because the relationship between the Barents Sea index and recruitment indices from analytic assessments is very non-linear, this prediction was based on a linear regression fitted on log-log scale. No such strong non-linearity is present for the other indices, and they were analyzed with linear regression models forced through the origin on natural scale.

Icelandic demersal survey index suggests extremely high recruitment, but this index has performed poorly in the past. Other indices suggest recruitment in 2006 to be low in comparison to the preceding 10-year period. Prediction from the Barents Sea survey is still strongish in the historic context. However, the Norwegian Sea (geographic term interpreted liberally for the total coverage) indices suggest very low recruitment — but these time series do not extend to the earlier low recruitment regime, such that we do not know yet how well these indices perform in predicting low recruitment. Nevertheless, they cover the known core nursery areas.

Recruitment predictions for years 2005–2006 (year classes 2004 and 2005) based on some aforementioned recruitment indices are given in the table below. For recruitment in 2005, they are reasonably coherent with each other but higher than the assessment-based estimate. The indices for recruitment in year 2006 have more spread but are nevertheless low. These indices suggests that year class 2005 is a poor one.

Data source	Time period	Recruitment 2005 (10^9)	Recruitment 2006 (10^9)
WG06 assessment	1981–2005	30.0	n.a.
Barents Sea winter survey	1981–2006	41.2	16.9
Norwegian Sea ecosystem survey, standard coverage	2000–2006	44.0	0.5
Norwegian Sea ecosystem survey, total coverage	2001–2005	46.4	5.8

In commercial catches, numbers of age 1 year blue whiting have been decreased by more than 50% from 2003 to 2005; these numbers are naturally affected by changes in the fisheries. The catch numbers of recruits in 2005 were about one third of the record set in 2001. Thus, commercial landings do not suggest drastic changes in recruitment. However, commercial landings do not yet provide information on the most interesting year class, that from year 2005.

4.9 Forecast

4.9.1 Short term forecast

Short term forecast was conducted with MFDP version 1a.

Input

Mean weight at age in the sea, mean weight in the catch, natural mortality and proportion mature were taken from 2005. The SMS assessment assumes a constant exploitation pattern for the period 1991–2005, and this was used in the projection.

Recruitment at age 1 in 2006 was assumed at $11.4 \cdot 10^9$. This is mean of two survey-based estimates, one from the Norwegian Sea ecosystem survey with total coverage (5.8) and one from the Barents Sea winter survey (16.9) (see Section above).

A geometric mean recruitment in 1995–2004 ($30.9 \cdot 10^9$) was used for recruitment in 2007. This corresponds to high recruitment regime and may turn out to be too optimistic.

For the fishery in 2006 it was assumed that the catch will reach 2.11 million tonnes, as stated in the management plan and the NEAFC agreement.

Table 4.9.1.1 gives an overview of the input data.

Output

The predicted catch and SSB are presented in Table 4.9.1.2. For $F=F_{pa}=0.32 \text{ yr}^{-1}$ catch is equal to about 985 thousand tonnes and SSB 3.7 million tonnes, well above the precautionary limit

$B_{pa}=2.25$ million tonnes. Also for $F=F_{lim}=0.51 \text{ yr}^{-1}$ the spawning stock stays well above B_{pa} . If Paragraph 4 of the agreed management plan (Section 4.2) is followed and TAC is reduced from 2.0 million tonnes in 2006 to 1.9 million tonnes in 2007, the spawning stock is still predicted to stay above the precautionary limit but this corresponds to fishing mortality ($F=0.73 \text{ yr}^{-1}$) that is well above the precautionary limit.

4.9.2 Medium term forecast

See evaluation of the management plan in Section 4.13.

4.10 Biological reference points

The present precautionary reference points have been introduced in the advice of ACFM in 1998. The values and their technical basis are:

Reference point	B_{lim}	B_{pa}	F_{lim}	F_{pa}
Value	1.5 mill t	2.25 mill. t	0.51 yr^{-1}	0.32 yr^{-1}
Basis	B_{loss}	$B_{lim} * 1.5$	F_{loss}	F_{med}

Although problems have been identified with these reference points they have remained unchanged since then. A major problem is that fishing at F_{pa} implies a high probability of bringing the stock below B_{pa} , in other words the present combination of F_{pa} and B_{pa} is inconsistent.

It should be noted that the PA reference points presently applied in the ICES advice are based on an ICA assessment in 1998 and are based on a relatively short time series. Since then regular changes have been made in the assessment by selecting other assessment methods or different assessment configurations. Also major changes have been observed in the stock and in the fishery. The assessments have frequently lead to different perceptions of the history of the development of the stock and the fishing mortality. PA reference points derived from these assessments would vary considerable between years. Since the introduction of the PA reference points the stock has moved into a period of high productivity. In such situations it may be inappropriate to adopt fixed reference points. Therefore, given the uncertainty in the assessment process, the WG was requested to develop management strategies which are less sensitive to the assessment results.

No attempt was made to recalculate the reference points in 2005. However the value of B_{lim} was reconsidered since all management strategies would have to comply with a low probability of bringing the SSB below B_{lim} .

SGPRP revisited the B_{lim} reference point for blue whiting in February 2003 (ICES 2003/ACFM:15). The current B_{lim} a value of 1.5 million t was based on an estimate of B_{loss} from an assessment in 1998. Since a segmented regression on the stock recruitment data was not significant, B_{loss} remains the obvious candidate for B_{lim} . Within the range of observed SSB there is no indication of reduced recruitment at low SSB. In the assessment carried out in 2002 B_{loss} was estimated to be 1.2 million t and SGPRP proposed this value for B_{lim} .

Based on assessments carried out in 2005 by WGNPBW, the B_{loss} is estimated between 1.4 million t (AMCI), 1.7 million t (ISVPA) and 1.6 million t (ICA and SMS), the same values as last year. If the value of B_{lim} is to be revised, it is likely to be around the region of the present value of 1.5 million tonnes.

No biological reference points review has been done in 2006 year by WGNPBW.

4.11 Management considerations

Blue whiting fisheries have entered a new era as agreement on a management plan was reached in the end of year 2005 (Section 4.2). This will guard against excessively high catches, but is no guarantee on sustainability if productivity of the stock declines (Section 4.13).

Potential yields are determined by current state of the blue whiting stock as well as future recruitment. All assessment models suggest that the stock is still very abundant, well above the precautionary level, although there has been a significant decline after the historic high reached around 2003. This high abundance is possible because recruiting year classes have been strong or extremely strong in the past years. In particular, all fully recruited year classes in the current spawning stock are very strong if seen in a historic perspective.

Present recruitment, the strength of year class 2005, is uncertain, but there are strong indications that it is weak (uncertainly lies in just how weak it is). This will significantly affect the spawning stock already in 2007. Therefore the fishery in 2007, if continued at present levels, will mainly be based on production from the presently recruited year classes as well as fishing the stock down.

Prediction on stock biomass in the beginning of 2008 is based on assumed recruitment in 2007 that corresponds to the high recruitment seen in recent years. This may turn out to be too optimistic. The estimate of SSB in 2008 is sensitive to the assumed recruitment, of which there is no information.

The future yields are determined by recruitment. The critical factor is then whether the weak recruitment in 2005 is a mere anomaly, or sign of recruitment returning to a level that was normal prior 1996? As the reasons for high recruitment level in 1996–2005 are unknown, we are not in position to say which scenario is more credible.

4.12 Quality of the data and the assessment

As in last year most assessments of blue whiting are based on statistical catch at age models using two surveys, the Norwegian survey on the spawning grounds and the international ecosystem survey in the Norwegian sea. One of the consequences of using statistical catch at age model is that the fishery of youngest age groups affects the recruitment estimates, that it would not do in a VPA type model.

As may be seen in figure 4.7.7.1 the estimated spawning stock and recruitment vary widely between different models that were run. All the models should be using the same data so this difference between models is an indication of discrepancy in the data as the difference between models lies mostly in different weighting of data.

Figure 4.7.5.8 illustrates this point well showing that by varying weight on different data sources the spawning stock in 2006 can vary from 4 to 6 million tons and the size of the 2004 year class from 15 to 40 billion fishes with the higher numbers obtained with more weight on surveys. Allowing for changes in selection pattern in time has the same effect as reducing weight on catches. A VPA type of model which has completely flexible exploitation pattern should follow a model that puts high weight on survey data so the XSA results presented look somewhat strange, except the shrinkage terms are causing this. The ICA uses a separable model for the last 8 years, starting a VPA from there so the weight of the catch at age data is probably less than in SMS that is a separable model. The settings of the AMCI model allowed selection pattern to change with time that has most likely the effect of increasing the weight of the surveys compared to a separable model.

Another way of looking at the quality of the assessment is to look at the standard errors produced by different assessment models, either through bootstrap, MCMC analysis or via the

Hessian. These standard errors are usually an underestimate of the “real standard” errors as structural uncertainty is not included. They can though be used as an index of uncertainty and compared for different stocks. Figure 4.7.5.12 show the estimated confidence intervals from the “default” SMS run indicating that the standard error in the estimate of the spawning stock in 2005 is around 600 thousand tonnes, Figure 4.13.2.1 does then indicate that the standard error in the spawning stock 2006 is around million tons and 2.5 million in the spawning stock in 2007.

A third method to get some ideas about the precision of assessment is through the retrospective pattern or consistency from one year to another. The retrospective pattern of blue whiting assessment (figure 4.7.5.6) indicates that it is very imprecise. Many of the surveys used are relatively short. In retrospective runs going more than 3–4 years back these series can not be used in the estimation, leading to the retrospective pattern indicating less precision of the assessment than is the reality for the current assessment. Compared to last year the SMS assessment gives similar perception of the state of the stock, but the AMCI and ICA results indicate a substantial upward revision of the stock.

The most striking different difference between the results of different assessment models and using different weights is in recruitment estimates. What is causing the difference in recruitment estimates could be the sharp reduction of age 1 in the catches in recent years (table 4.5.5.7) that is picked up by the catch at age models as an indication of reduced number of age 1. There are though information from the fisheries that the effort towards age 1 blue whiting has reduced. A third piece of information about recruitment is that the number of age 2 in the Norwegian spawning stock survey that is not used for tuning has reduced much in recent years. This reduction could be caused by later maturation or problems with sampling but it can though not be excluded that it is a sign of reduced recruitment with the May survey in the Norwegian sea overestimating recruitment. There are indications that the 2005 year class is very small and will lead to sharp increase in fishing mortality in 2008 if the current level of TAC is continued. There is only one survey behind the estimate of this year class but considering the extent of the Ecosystem survey in May 2006 it seems likely that this year class is small.

To summarize, the assessment of blue whiting very uncertain with CV on the spawning stock estimate in 2006 and 2007 exceeding 25 and 35%. The quality of the assessment has though improved considerably in recent years, mostly due to more data on recruitment. As the Norwegian spawning stock and the international ecosystem surveys will likely continue, the assessment might improve further in the coming years. Reducing fishing effort will lead to less proportion of the youngest age groups in the spawning stock and the fisheries and make predictions more reliable.

4.13 Evaluation of the “Arrangement for the Multi-Annual management of the Blue whiting Stock”

On 16 December 2005, the Delegations of the European Community, the Faroe Islands, Iceland, and Norway (referred to as the Parties) signed an Agreed Record on conclusions of fisheries consultations on the management of blue whiting stock in the Northeast Atlantic.

According to the Agreed Record, the Delegations agreed to ask ICES to evaluate whether the multi-annual management arrangement (see section 4.1.3.1 below) is in accordance with the precautionary approach.

This section includes an evaluation of the agreement. Two approaches are taken: one approach analyses the full management and one focus on necessary steps to bring the current F down to Fpa.

Agreed arrangement

The full text of “Arrangement for the Multi-Annual Management of the Blue Whiting Stock” can be found in section 4.2 with the title “annex II”.

Interpretation of management plan

Paragraph 4 in the agreed record includes a rule for the intermediate phase between the 2006 TAC and the year when Fpa reach a target at 0.32. This paragraph is interpreted as the TAC should be decreased by 100 000 t until mean F is at or below Fpa for the first time.

Paragraph 5 is interpreted as Fpa is used as a target F, such that F should be set at Fpa when possible.

Paragraph 6 uses Bpa as a trigger point for SSB, and it is interpreted as SSB should reach Bpa after the TAC is taken. “Rapid recovery” is interpreted as within one year, such that the TAC should be set to allow a SSB after the implementation at Bpa. It is interpreted that paragraph 6 overrules the initial condition defined by paragraph 4 if SSB drops below Bpa in any year.

4.13.1 Methodology

The evaluation was done using the SMS (Stochastic Multi Species model; Lewy and Vinther, 2004) assessment model and forecast. When SMS is used as a forecast program, the stock is projected forward in time using the maximum likelihood estimate of the model parameters and the population in the terminal year as initial stock size. The age effect from the F-model is kept constant and a year factor is derived dynamically from a Harvest Control Rule. Recruits are produced from the stock/recruitment relation and input parameters. For a stochastic projection, the number of recruits calculated is altered by a factor drawn from a truncated normal distribution with a known standard deviation. By making a high numbers of projection, mean and variance of future stock numbers, SSB yield etc. can be calculated.

The approach taken in this implementations of HCR is based on the framework for evaluation of management strategies as described by ICES study group on management strategies (ICES 2005/ACFM:09, 2006/ACFM:15) and used for a range of stocks, e.g. presented in the report of the ICES *ad hoc* group on long term advice (ICES 2005/ACFM:25).

Uncertainties in stock assessment

The state of the stock is a prerequisite for application of harvest control rules, however the true stock size is not known. The ICES procedure is to make an assessment each year to get an estimate of the true stock. This estimate is then projected forward in time using a HCR such that the TAC can be calculated. The SMS approach does not simulate the full annual cycle of assessment and projection. Instead, it is assumed that the true stock size can be “observed” with some bias and noise and it is this “perceived” stock that makes the basis for the use of HCR and estimation of a TAC. The true stock size is assumed know in the first projection year and is later updated annually by recruitment and catches derived from application of HCR on the “perceived” stock.

The “observation” error applied to the real stock to get the perceived stock is defined from a bias factor and observation noise. The observation noise can be specified as random number from a normal distribution with a known coefficient of variation (CV), or as a random number from a lognormal distribution with known standard deviation (std)

Example: “observed” stock numbers at age (N_{obs}) are derived from the “true” stock numbers (N_{true}):

$$\text{normal distributed noise: } N_{obs} = N_{true} * (bias + CV * NORM(0,1))$$

$$\text{or log normal noise: } N_{obs} = N_{true} * bias * e^{(std * NORM(0,1))}$$

Where $NORM(0,1)$ is a random number drawn from a normal distribution with mean 0 and variance 1.

The true uncertainty of e.g. stock numbers cannot be estimated. Given data and model the estimated stochastic uncertainty can be used as a qualified guess on a minimum uncertainty in the assessment. The SMS assessment estimates uncertainties on stock numbers (figure 4.13.1) from the Hessian matrix. The simulations mimic that a TAC is set on the basis of stock numbers estimated the 1 Jan the year after the last assessment year. Such are similar to the ones labelled CV-2005 in figure 4.13.1. The CV is slightly lower than 25% for the mid age range that contributes to most to the catch and higher for younger and older fish. A CV at 25% was chosen as the default uncertainty of the assessment.

There are two options for noise for stock numbers. The same noise, or more correctly the result of one draw the $NORM(0,1)$ function, can be used for all age groups of N in given year, or each individual age group has its own, independent, noise. SMS estimates correlation coefficients between N at age in the terminal year the range 0.3-0.9 which indicates that the same noise (equivalent to correlation coefficient 1.0) should be used for all ages.

The retrospective pattern of SSB indicates that SSB systematically has been underestimated in the SMS assessments for the most recent periods, which is similar to a bias factor less than one. However, SSB has been increasing in the same period. For a declining stock, a systematic overestimate is more common seen in assessments, and probably the case for the blue whiting assessment as well.

The risk of over fishing is highest for a declining stock and arbitrary chosen bias factor were tried in the scenarios.

Uncertainties in implementing TAC

A similar error function as specified above can be applied to the implementation of the outcome of the HCR, such that the realised TAC differs from the defined.

To what extent the TAC has been overshoot in the past is not possible to answer, as no TAC was agreed 1997-2005. The estimated catch was however often a factor 2-4 higher than the ICES advice.

A CV at 10% and various bias factors greater than 1.0 were applied in scenarios as a kind of sensitivity test.

Stock recruitment relationship

The stock recruitment relationship and its variability are essential for the results of the simulations done. Estimated stock and recruitments for the assessment period show no clear relation between recruitment and SSB (Figure 4.13.3). For the period 1981-1995 both SSB and recruitment were in general at a lower level than for the most recent period 1996-2004. For the first period there seems to be a negative correlation between SSB and recruitment while recruitment in the second period seems rather independent of SSB. In lack of a clear stock recruitment relation, two recruitment options are suggested.

- a) Hockey stick relation with breakpoint 1500000 t (Blim) fitted to 1981-1995 data
- b) Hockey stick relation with breakpoint 2500000 t fitted to 1996-2004 data

Scenario a) can be seen as the “worst case scenario” representing a low productivity period, while scenario b) is based only the most recent observation and will produce the highest recruitment with the present level of SSB.

Overview of methodology

An overview of the simulation methodology is presented below and on Figure 4.13.4.

1. Make an assessment with terminal year Y to estimate “true” stock numbers
2. Increase year by one: $Y=Y+1$
3. Project true stock numbers to 1. Jan year Y
4. Put noise and bias on true $N(Y)$ to produce observed $N(Y)$ (this simulates and assessment)
5. Estimate observed recruits from observed SSB and “true” SSB-R relation
6. Project observed $N(Y)$ to $N(Y+1)$ using observed TAC(Y, fixed exploitation pattern and recruitment from true SSB-R relation
7. Apply HCR to estimate observed TAC(Y+1)
8. Apply implementation bias and noise to calc true TAC(Y+1)
9. Estimate true recruits(Y) from true SSB-R relation and uncertainty
10. Estimate true F(Y) from true $N(Y)$ and true TAC(Y). Optionally adjust true TAC(Y) with cap F before this calculation.
11. go to 2

Initial stock numbers

The final SMS assessment including 2004 catches (ICES CM 2006/ACFM:05) are used as basis for the evaluation. Catch in 2005 is assumed to be 2130000 tons and catches in 2006 to 2000000 t. $F(2004)$ status quo is used as exploitation pattern. Catches in 2005 and 2006 were assumed implemented without errors.

For easier scenario comparison recruitment at $36.4E6$ (GM 1996-2004) is used for 2005 for all runs irrespective of the stock recruitment relation used in the scenario. Number of recruits in 2006 and later is estimated from the chosen stock-recruitment function.

4.13.2 Simulations

The evaluation of the management plan will focus on recruitment scenario a), which reflect the situation in 1981-1995 with a relative low stock size and low recruitment level. For the more recent period 1996-2005 the recruitment has been higher, but so far it has not been possible to fully explain reasons for the shift in stock productivity. By choosing the low recruitment level from 2006 onwards, the simulations will investigate whether the HCR is capable to react swiftly and reduce F in time given uncertainties and bias in both stock assessment and implantation.

Scenario 1, the naïve approach

This scenario test the effects of assessment noise

Recruitment	Low level	
Assessment	Noise	25%CV, correlated
	Bias	1, no bias
Implementation	Noise	No noise
	Bias	1, no bias

Two set of standard graphs (Figure 4.13.5-4.13.6) are shown for the scenario results; the first show the median and the 25th and 75th percentiles in 1000 simulations for SSB, recruits, yield and mean $F_{3.7}$. The probability of having a SSB below B_{pa} and B_{lim} is also shown. All results are shown for period 2005-2050. The second standard set of graphs show the distributions of SSB, mean F and yield for the period (2020-2050) where the results are assumed independent

of the initial conditions. It also shows the distributions of relative changes in the same variables from one year to another. The cumulate probability is overlaid the histogram, e.g. the Yield graph show there is a probability of around 25% of having zero TAC.

Due to the shift in recruitment level both SSB and F drops very fast in the period 2007-2010. Yield is reduced from around 2 million t to 0.5 million t in the same period showing that it is paragraph 6 (conditions with $SSB < Bpa$) in the management plan that dictates the TAC. It also how that the proposed minimum TAC reduction of 0.1 million t in paragraph 4 is not adequate if the recruitment level is low.

The target of the management plan, to keep SSB above Blim, is however reached, as the probability of getting below Blim is just 2-3% in the first years after a drop in recruitment level.

The probability of getting a Bpa below SSB is around 40%. The management plan aim to maintain SSB above Bpa and the poor performance is partly due the uncertainty on the terminal stock numbers and in particular due to the uncertainty of the recruitment. In the simulation, the recruitment used for estimating the TAC is the recruitment in the intermediate year and the TAC year are estimated from the (true) stock recruitment relation. This is simply done by using the SSB/R relation and the “observed” SSB with an assumption of no noise. The true recruitment is based on the same relation and the true SSB, however in this case the variance of the SSB/R is taken into account. In the simulation, it is inconsistent to used the true SSB/R relation calculate TAC. However, as we simulate a transition from high to low productivity, the recruitment estimates are very conservative as a low recruitment is the result. In real assessment a higher recruitment level, based on the most recent observation will probably have been used. Therefore, the simulated probability of getting below Blim is probably an underestimate.

To conclude: Given the applied methodology and the rather naïve scenario with a limited uncertainty on the assessment as the only source for uncertainty, the management plan is in agreement with the precautionary approach.

Scenario 2, sensitivity to assessment bias

This scenario tests the effects of assessment bias.

Recruitment	Low level	
Assessment	Noise	25% CV, correlated
	Bias	In the range 0.7-1.3
Implementation	Noise	No noise
	Bias	1, no bias

The results of applying various levels (0.7 to 1.3) of assessment bias are presented in Figure 4.13.7. With a consistent overestimate of the stock size (bias >1), equilibrium mean F and yield increase with a resulting SSB decrease. The probability of having a SSB below Blim is above 5% for assessment bias greater than 1.05. This shows that the management plan is sensitive to assessment bias and that only a very low value of bias brings SSB below Blim.

Scenario 3, sensitivity to implementation bias

This scenario tests the effects of implementation bias.

Recruitment	Low level	
Assessment	Noise	25% CV, correlated
	Bias	1, no bias
Implementation	Noise	10% CV
	Bias	In the range 0.7-1.3

The results of applying various levels (0.7 to 1.3) of implementation bias are presented in Figure 4.13.8. The probability of having SSB below Blim is greater than 5% when implementation bias is greater than 1.1

Scenario 4, sensitivity to assessment bias in combination with implementation bias

This scenario tests the effects of implementation bias given both assessment noise and bias

Recruitment	Low level	
Assessment	Noise	25%CV, correlated
	Bias	1.2
Implementation	Noise	10% CV
	Bias	In the range 0.7-1.3

The results (Figure 4.13.9) shows that a consistent overestimate of the stock size by 20% in combination with a rather low (10% CV) noise on implementation bias will lead to a probability of SSB<Bpa of more than 5% for any implementation bias greater than 0.9.

Scenario 5, High recruitment level

This scenario tests the “worse case scenario” with respect to assessment and implementation noise and bias, however with an assumption of high recruitment level.

Recruitment	High level	
Assessment	Noise	25%CV, correlated
	Bias	1.2
Implementation	Noise	10% CV
	Bias	In the range 0.7-1.3

Given a high recruitment level, the management plan is robust to uncertainties and bias in both assessment and implementation (Figure 4.13.10). The mean TAC will be in the order of 2 million t and mean SSB between 4 and 8 million t. The probability of SSB<Bpa is very close to zero.

4.13.3 Evaluation of the initial conditions

The agreed arrangement, paragraph 4 specifies conditions how the transition from the present high F to Fpa should be done. The Parties agreed to decrease the TAC by at least 100 000 tonnes until the target F=0.32 was reached. Considering TAC of 2 million tonnes in 2006 100 thousand tonnes must be considered a tiny reduction. This section evaluates the possible outcome of applying paragraph 4.

Recruitment of blue whiting has been good in recent years with mean recruitment of 40 billion at age 1 from year classes 1996-2004 compared to 10 billion from year classes 1981 - 1995. With a yield of 45 g/recruit the mean annual yield from the recent year classes can be expected to be 1.8 million tonnes but around 500 thousand tonnes in the low production period when the yield per recruit is little higher.

One of the scenarios that the 100 thousand tonnes catch stabilizer needs to be tested against is a sudden shift from high to low recruitment period. The 2006 ecosystem in the Norwegian sea indicates that the 2005 year class is much smaller than other year classes that have been seen in that survey that started in 2000. Whether this is a single incident or shift to a low production period is not known nor is the exact size of the 2005 year class. In the model here data on age 1 from the whole area covered by the ecosystem survey was used and the estimated size of the 2005 year class was 6 billion individuals at age 1 which is a very small year class.

To test the effect of the "catch stabilizer" a short term prognosis was run until the year 2008 with a TAC of 2 million tonnes in 2006, 1.9 million in 2007 and 1.8 million in 2008. Strength

of the 2005 year class was estimated from the Norwegian sea ecosystem survey but 3 scenarios were investigated regarding the strength of year classes 2006 and 2007

1. Geometric mean of the 1981–2003 year classes or 15 billion age 1 fishes. This is an assumption that the high production period has ended.
2. The size of year classes 2006 and 2007 was 30 billion at age 1 or similar to the 2003 and 2004 year classes.
3. The size of year classes 2006 and 2007 was as that of year classes 1996 - 2005 (40 billion at age 1)

Figure 4.13.2.1 shows that the probability of $SSB < B_{pa}$ will be high if recruitment in coming years will be low. According to the agreement, other measures should in that case take over the 100 thousand tonnes catch stabilizer. If assumed recruitment is better the probability of going below B_{pa} reduces but will though be considerable. Figure 4.13.2.2 shows the estimated fishing mortality for the 3 scenarios indicating that fishing mortality will in all cases increase in next two years, although the goal is to approach target fishing mortality of 0.32.

In summary these analyses indicate that a catch stabilizer of 100000 tonnes will lead to the stock falling below B_{pa} with high probability except recruitment continues to be good. Due to the small 2005 year class it will also lead to increased fishing mortality in the next 2 years in spite of the intention to reduce fishing mortality.

4.13.4 Conclusion

A simulation framework as presented here will always have limitations and can only mimic the real world in an inadequate way. It is however considered that the conclusions made can be used as guidance for formulating management plans.

Blue whiting stock assessment shows a shift to higher recruitment from the mid 1990s. The reason for this shift is not fully understood and it is not possible to predict, if and when a possible shift back to a lower recruitment level will occur. Preliminary estimate of the 2005 year class indicates a low recruitment. This might be an anomaly in the high recruitment series, or a return to the low recruitment level – we do not know. Therefore the evaluation of the management should also include the simulations of a shift from a higher to a lower recruitment level.

The simulations show that, given the high recruitment level observed for the period 1996–2005, the management plan is robust to uncertainties in both assessment and implementation and in accordance with the precautionary approach.

For low recruitment scenarios, the management plan is not considered precautionary unless given unrealistic low levels of noise and bias in both stock assessment and implementation of the TAC advice.

The effect of the applying paragraph 4 in the agreement without taking paragraph 6 into account indicates that a catch stabilizer of 100000 tonnes will lead to the stock falling below B_{pa} with high probability except if recruitment continues to be good. However, even with reasonably good recruitment after 2006, the catch stabilizer of 100000 tonnes will likely lead to increasing F in the near future.

4.14 Recommendations

- The Working Group recommends exploring the possibilities of creating a coherent time series from surveys in the spawning area, including the international blue whiting spawning stock survey (carried out in 2004–2006, and in the future years). The data should be prepared and evaluated by PGNAPES before Working Group convenes the next year.

- The Working Group recommends that surveys, which provide information on recruitment of blue whiting should be continued in the same way as in the past. Better coordination of the surveys carried out in different areas is required.
- The Working Group asks ICES to remind member countries that reliable catch statistics are required to enable proper analyses. All countries which have catches of blue whiting should timely report these to ICES.
- The Working Group asks member countries to adhere to the new fleet definitions (Table 4.3.9) when reporting catches.
- The Working Group recommends continual exchange of age reading expertise between different countries in order to ensure coherence in aging of blue whiting.
- The Working Group recommends to its members to recompile the time series of catch at age data on an area basis, which allows to analyse the effect of changing behaviour of the distribution of the fleet. In particular, separate catch at age data for the Norwegian Sea are required.
- The Working Group recommends to the institutes participating in the Norwegian Sea Ecosystem Survey (coordinated by PGNAPES) to make survey data of blue whiting available to PGNAPES in the agreed format to allow for extension of the time series to the years before 2000.
- The Working Group recommends investigating whether current maturity ogives should and could be revised.
- The blue whiting sub group recommends the next meeting to be held in Vigo, Spain.

Table 4.3.1 Landings (tonnes) of BLUE WHITING from the directed fisheries (Sub-areas I and II, Division Va, XIVa and XIVb) 1987–2005, as estimated by the Working Group.

Country	1987	1988	1989 ³⁾	1990	1991	1992	1993	1994 ²⁾	1995 ³⁾	1996	1997	1998	1999	2000	2001	2002	2003	2004	2005
Denmark	-	-	-	-	-	-	-	-	-	-	-	-	15	7,721	5,723	13,608	38,226	23,437	365
Estonia	-	-	-	-	-	-	-	-	-	377	161	904	-	-	-	-	-	-	-
Faroes	9,290	-	1,047	-	-	-	-	-	-	345	-	44,594	11,507	17,980	64,496	82,977	115,755	109,380	64,639
Germany	1,010	3	1,341	-	-	-	-	2	3	32	-	78	-	-	3117	1,072	813	488	569
Greenland	-	-	-	-	-	-	-	-	-	-	-	-	-	-	-	-	-	-	-
Iceland	-	-	4,977	-	-	-	-	-	369	302	10,464	68,681 ⁴⁾	96,295	155,024	245,814	195,483	312,334	279,811	145,640
Latvia	-	-	-	-	-	-	-	422	-	-	-	-	-	-	-	-	-	-	-
Netherlands	-	-	-	-	-	-	-	-	72	25	-	63	435	-	5180	906	592	1,365	-
Norway ⁵⁾	-	-	-	-	-	-	-	-	-	-	-	-	-	-	64,581	100,922	215,075	302,166	9,778
Norway ⁶⁾	-	-	-	566	100	912	240	-	-	58	1,386	12,132	5,455	-	28,812	-	-	22167	6,793
Poland	56	10	-	-	-	-	-	-	-	-	-	-	-	-	-	-	-	-	-
Scotland	-	-	-	-	-	-	-	-	-	-	-	-	-	-	-	-	-	-	64
Sweden	-	-	-	-	-	-	-	-	-	-	-	-	-	-	-	850	57,206	15,794	785
USSR/ Russia ¹⁾	112,686	55,816	35,250	1,540	78,603	61,400	43,000	22,250	23,289	22,308	50,559	51,042	65,932	103,941	173,860	145,649	191,507	166,677	177,008
Total	123,042	55,829	42,615	2,106	78,703	62,312	43,240	22,674	23,733	23,447	62,570	177,494	179,639	284,666	591,583	541,467	931,508	921,349	405,577

¹⁾ From 1992 only Russia²⁾ Includes Vb for Russia.³⁾ Icelandic mixed fishery in Va.⁴⁾ include mixed in Va and directed in Vb.⁵⁾ Directed fishery⁶⁾ By-catches of blue whiting in other fisheries.**Table 4.3.2** Landings (tonnes) of BLUE WHITING from directed fisheries (Division Vb, VIa,b, VIIa,b,c and Sub-area XII) 1987–2005, as estimated by the Working Group.

Country	1987	1988	1989	1990	1991	1992	1993	1994	1995	1996	1997	1998 ¹⁾	1999	2000	2001	2002	2003	2004	2005
Denmark	2,655	797	25	-	-	3,167	-	770	-	269	-	5051	19,625	11,856	18,110	2,141	17,813	44,992	24,731
Estonia	-	-	-	-	-	6,156	1,033	4,342	7754	10,605	5,517	5,416	-	-	-	-	-	-	4)
Faroes	70,625	79,339	70,711	43,405	10,208	12,731	14,984	22,548	26,009	18,258	22,480	26,328	93,234	129,969	188,464	115,127	208,427	206,078	197,134
France	-	-	2,190	-	-	-	1,195	-	720	6,442	12,446	7,984	6,662	13,481	13,480	14,688	13,365	-	8,046
Germany	3,850	5,263	4,073	1,699	349	1,307	91	-	6,310	6,844	4,724	17,891	3,170	12,655	15,862	15,378	21,866	13,813	22,089
Iceland	-	-	-	-	-	-	-	-	-	-	-	-	64,135	105,833	119,287	91,853	189,159	99,832	119,569
Ireland	3,706	4,646	2,014	-	-	781	-	3	222	1,709	25,785	45,635	35,240	25,200	29,854	17,723	22,484	62,730	73,174
Japan	-	-	-	-	-	918	1,742	2,574	-	-	-	-	-	-	-	-	-	-	-
Latvia	-	-	-	-	-	10,742	10,626	2,160	-	-	-	-	-	-	-	-	-	-	-
Lithauen	-	-	-	-	-	-	2,046	-	-	-	-	-	-	-	-	-	-	-	-
Netherlands ²⁾	5,627	800	2,078	7,280	17,359	11,034	18,436	21,076	26,703	17,644	23,676	27,884	35,408	46,128	68,415	33,365	45,239	82,520	143,470
Norway	191,012	208,416	258,386	281,036	114,866	148,733	198,916	226,235	261,272	337,434	318,531	519,622	475,004	460,274	399,932	385,495	502,320	486,843	622,981
UK (Scotland)	3,315	5,071	8,020	6,006	3,541	6,849	2,032	4,465	10,583	14,325	33,398	92,383	98,853	42,478	50,147	26,403	27,136	56,326	104,526
Sweden	-	-	-	-	-	-	-	-	-	-	-	-	-	-	-	10	-	-	-
USSR/ Russia ³⁾	165,497	121,705	127,682	124,069	72,623	115,600	96,000	94,531	83,931	64,547	68,097	79,000	112,247	141,257	141,549	144,419	163,812	179,400	150,014
Total	446,287	426,037	475,179	463,495	218,946	318,018	347,101	378,704	423,504	478,077	514,654	827,194	943,578	989,131	1,045,100	846,602	1,211,621	1,232,534	1,465,735

¹⁾ Including some directed fishery also in Division IVa.²⁾ Revised for the years 1987, 1988, 1989, 1992, 1995, 1996, 1997³⁾ From 1992 only Russia⁴⁾ Reported to the EU but not to the ICES WGNPBW. (Landings of 19,467 tonnes)

Table 4.3.3 Landings (tonnes) of BLUE WHITING from directed fisheries and by-catches caught in other fisheries (Divisions IIIa, IV) 1987–2005, as estimated by the Working Group.

Country	1987	1988	1989	1990	1991	1992	1993 ³⁾	1994	1995	1996	1997	1998 ²⁾	1999	2000	2001	2002	2003	2004	2005
Denmark ⁴⁾	28,541	18,144	3,632	10,972	5,961	4,438	25,003	5,108	4,848	29,137	9,552	40,143	36,492	30,360	21,995				
Denmark ⁵⁾			22,973	16,080	9,577	26,751	16,050	14,578	7,591	22,695	16,718	16,329	8,521	7,749	7,505	35,530	26,896	21,071	16,354
Faroes ⁴⁾⁶⁾	7,051	492	3,325	5,281	355	705	1,522	1,794	-	6,068	6,066	-	-	-	60	7,317	5,712	6,864	1,437
Faroes ⁵⁾⁶⁾												296	265	42	6,741				3,589
Germany ¹⁾	115	280	3	-	-	25	9	-	-	-	-	-	-	-	81	-	36	19	17
Iceland																			307
Ireland	-	-	-	-	-	-	-	-	-	-	-	-	-	-	-	4		4	9
Netherlands	-	-	-	20	-	2	46	-	-	-	793	-	-	-	-	50	0	0	0
Norway ⁴⁾	24,969	24,898	42,956	29,336	22,644	31,977	12,333	3,408	78,565	57,458	27,394	28,814	48,338	73,006	21,804	85,062	117,145	107,311	98,938
Norway ⁵⁾															58,182				
Russia	-	-	-	-	-	-	-	-	-	-	-	-	-	-	69	-	-		5,204
Scotland																		35	3
Sweden	2,013	1,229	3,062	1,503	1,000	2,058	2,867	3,675	13,000	4,000	4,568	9,299	12,993	3,319	2,086	17,689	8,326	3,289	2,175
UK	-	100	7	-	335	18	252	-	-	1	-	-	-	-	-	-	65		
Total	62,689	45,143	75,958	63,192	39,872	65,974	58,082	28,563	104,004	119,359	65,091	94,881	106,609	114,476	118,523	145,652	158,180	138,593	128,033

¹⁾ Including directed fishery also in Division IVa.

²⁾ Including mixed industrial fishery in the Norwegian Sea

³⁾ Imprecise estimates for Sweden: reported catch of 34265 t in 1993 is replaced by the mean of 1992 and 1994, i.e. 2,867 t, and used in the assessment.

⁴⁾ Directed fishery

⁵⁾ By-catches of blue whiting in other fisheries.

⁶⁾ For the periode 1987-2000 landings figures also include landings from mixed fisheries in Division Vb.

Table 4.3.4 Landings (tonnes) of BLUE WHITING from the Southern areas (Sub-areas VIII and IX and Divisions VIIg-k and VIII,e) 1987–2005, as estimated by the Working Group.

Country	1987	1988	1989	1990	1991	1992	1993	1994	1995	1996	1997	1998	1999	2000	2001	2002	2003	2004	2005
France																			
Germany	-	-	-	-	-	-	-	-	-	-	-	-	-	-	-	600 ²⁾	88 ²⁾	973	148
Ireland	-	-	-	-	-	-	-	-	-	-	-	-	-	-	-	98 ²⁾	96 ²⁾	12,659	305
Netherlands	-	-	-	450	10	-	-	-	-	-	-	10 ¹⁾	-	-	-	3208 ²⁾	2471,8 ²⁾	11,426	4,313
Norway	4	-	-	-	-	-	-	-	-	-	-	-	-	-	-	-	-	-	39197
Portugal	9,148	5,979	3,557	2,864	2,813	4,928	1,236	1,350	2,285	3,561	2,439	1,900	2,625	2,032	1,746	1,659	2,651	3,937	5,190
Russia																			685
Scotland																			603
Spain	23,644	24,847	30,108	29,490	29,180	23,794	31,020	28,118	25,379	21,538	27,683	27,490	23,777	22,622	23,218	17,506	13,825	15,612	17,643
UK	23	12	29	13	-	-	-	5	-	-	-	-	-	-	-	-	181		
France	-	-	1	-	-	-	-	-	-	-	-	-	-	-	-	-	-	784	
Total	32,819	30,838	33,695	32,817	32,003	28,722	32,256	29,473	27,664	25,099	30,122	29,400	26,402	24,654	24,964	23,071	20,097	85,093	27,608

¹⁾ Directed fisheries in VIIIa

²⁾ Landings reported as Directed fisheries and included in the Catch-at-Age calculations of that fisheries

Table 4.3.5 Total landings of blue whiting by country and area for 2005 in tonnes.

Area	Denmark	Islands Faroe	France	Germany	Iceland	Ireland	Norway	Portugal	Russia	Scotland	Spain	Sweden	Netherlands	Grand Total
IIa	365	41,161		246	97,571		16,571		155,173			785		311,872
IIb		435		324	34		0		21,835					22,628
IIIa	282	0					300					1,244		1,826
IVa	16,068	5,026		17	307	9	98,638		5,204	3		916		126,187
IVb	4	0					0					16		20
IXa		0					0	5,190						5,190
Va		23,042			48,035		0							71,077
Vb	8,674	97,197		3,319	109,320	560	28,597		83,945	2,805			11,812	346,230
VIa	4,757	11,935		11,561	4,455	42,512	84,524			50,258			75,175	285,176
VIb		25,645			5,794	1,898	276,426		46,680	7,264			383	364,089
VIIb	2,334	0		90		6,489	0			2,374			212	11,499
VIIc	8,966	41,996	8,046	7,083		21,716	227,969		2,918	41,825			55,888	416,407
VIIg		0				191	0							191
VIIIa		0					0						383	383
VIIIc+IXa		0					0				17,643			17,643
VIIj		0		148		114	0			10			2,066	2,337
VIIk		0					0						1,864	1,864
XII		20,361		36			5,465		16,471					42,333
Grand Total	41,450	266,799	8,046	22,823	265,516	73,488	738,490	5,190	332,226	104,539	17,643	2,960	147,783	2,026,953

Table 4.3.6 Landings (tonnes) of BLUE WHITING from the main fisheries, 1987–2005, as estimated by the Working Group.

Area	Norwegian Sea fishery (Sub-areas 1+2 and Divisions Va, XIVa-b)	Fishery in the spawning area (Divisions Vb, VIa, VIb and VIIb-c)	Directed- and mixed fisheries (Divisions IIIa and IV)	Total northern areas	Total southern areas (Subareas VIII and IX and Divisions VIId, e, g-k)	Grand total
1987	123,042	446,287	62,689	632,018	32,819	664,837
1988	55,829	426,037	45,143	527,009	30,838	557,847
1989	42,615	475,179	75,958	593,752	33,695	627,447
1990	2,106	463,495	63,192	528,793	32,817	561,610
1991	78,703	218,946	39,872	337,521	32,003	369,524
1992	62,312	318,081	65,974	446,367	28,722	475,089
1993	43,240	347,101	58,082	448,423	32,256	480,679
1994	22,674	378,704	28,563	429,941	29,473	459,414
1995	23,733	423,504	104,004	551,241	27,664	578,905
1996	23,447	478,077	119,359	620,883	25,099	645,982
1997	62,570	514,654	65,091	642,315	30,122	672,437
1998	177,494	827,194	94,881	1,099,569	29,400	1,128,969
1999	179,639	943,578	106,609	1,229,826	26,402	1,256,228
2000	284,666	989,131	114,477	1,388,274	24,654	1,412,928
2001	591,583	1,045,100	118,523	1,755,206	24,964	1,780,170
2002	541,467	846,602	145,652	1,533,721	23,071	1,556,792
2003	931,508	1,211,621	158,180	2,301,309	20,097	2,321,406
2004	921,349	1,232,534	138,593	2,292,476	85,093	2,377,569
2005	405,577	1,465,735	128,033	1,999,345	27,608	2,026,953

Table 4.3.7 Total landings of blue whiting by quarter and area for 2005 in tonnes. Landing figures provided by Working Group members.

Area	Quarter 1	Quarter 2	Quarter 3	Quarter 4	Grand Total
IIa	4,651	170,653	80,145	56,423	311,872
IIb		170	4,478	17,980	22,628
IIIa	176	150	1,156	343	1,826
IVa	13,000	45,055	41,338	26,795	126,187
IVb		1	8	11	20
IXa south	610	1,288	1,684	1,608	5,190
Va		47,746	21,633	1,699	71,077
Vb	17,368	304,492	245	24,125	346,230
VIa	59,799	225,377			285,176
VIb	317,128	46,642	319		364,089
VIIb	11,324		175		11,499
VIIc	408,361	8,046			416,407
VIIg	191				191
VIIIa			383		383
VIIIc+IXa	4,904	5,389	3,866	3,484	17,643
VIIj	674	1,664			2,337
VIIk	1,864				1,864
XII	42,333				42,333
Grand Total	882,383	856,673	155,429	132,468	2,026,953

Table 4.5.1.1. Blue whiting. Total landings, No. of samples, No. of fish measured and No. of fish aged by country and quarter for 2005.

Country	Quarter	Landings (t)	No. Samples	No. Fish measured	No. Fish aged
Denmark	1	22202	13	207	951
	2	19030	13	1030	1127
	3	214	2	2	2
	4	4	1	1	1
	Total	41450	29	1240	2081
Faroe Islands	1	93398	20	1200	2640
	2	148657	26	1300	2861
	3	13830	4	200	374
	4	10914	48	1800	4125
	Total	266799	98	4500	10000
France	1				
	2	8046	0	0	0
	3				
	4				
	Total	8046	0	0	0
Germany	1	12822	0	0	0
	2	9621	52	1122	18719
	3	373	0	0	0
	4	8	0	0	0
	Total	22823	52	1122	18719
Iceland	1	5794	2	99	178
	2	230840	92	4516	7733
	3	18281	14	636	841
	4	10601	1	50	100
	Total	265516	109	5301	8852
Ireland	1	43366	26	3902	4019
	2	30122	6	601	1020
	3				
	4				
	Total	73488	32	4503	5039
Norway	2	479632	134	2458	9247
	4	192794	235	2169	13235
	6	43169	103	460	4439
	8	22895	63	196	2915
	Total	738490	535	5283	29836
Portugal	1	610	68	156	7879
	2	1288	74	232	8474
	3	1684	32	228	3801
	4	1608	94	185	11740
	Total	5190	268	801	31894
Russia	1	73143	142	2002	26019
	2	104624	83	1611	16809
	3	71861	115	977	22812
	4	82598	123	1357	19825
	Total	332226	463	5947	85465
Scotland	1	72611	8	1398	332
	2	31929	5	537	231
	3				
	4				
	Total	104539	13	1935	563
Sweden	1	0	0	0	0
	2	1010	0	0	0
	3	1594	0	0	0
	4	356	0	0	0
	Total	2960	0	0	0
Spain	1	4904	36	4808	250
	2	5389	50	5715	250
	3	3866	49	5863	387
	4	3484	34	6105	412
	Total	17643	169	22491	1299
The Netherlands	1	73901	55	1375	1375
	2	73323	10	250	250
	3	558	0	0	0
	4	0	0	0	0
	Total	147783	65	1625	1625
Grand Total		2026952	1833	54748	195373

Table 4.5.1.2 Blue Whiting. Sampling levels in 2005 per area.

Area	Landings	Nos samples	Nos aged	Nos measured
IIa	311872	446	5656	42196
IIb	22628	102	975	16545
IIIa	1826	30	186	1075
IVa	126187	161	2506	9866
IVb	20	0	0	0
IXa south	5190	268	801	31894
Va	71077	36	1755	3234
Vb	346230	120	5024	22289
VIa	285176	117	4623	17074
VIb	364089	253	3617	38646
VIIb	11499	5	404	961
VIIc	416407	95	4669	7814
VIIg	191	0	0	0
VIIIa	383	0	0	0
VIIIc+IXa	17643	169	1299	22491
VIIj	2337	0	0	0
VIIk	1864	1	25	25
XII	42333	30	644	3827
Total general	2026952	1833	32184	217937

Table 4.5.4.1 Blue whiting. Landing in numbers ('000) by length group (cm) and quarters for the Nothern area in 2005.

Length	Q1	Q2	Q3	Q4	All year
5					
6					
7			11		11
8					
9	869				869
10	10				10
11		12			12
12	10	12			22
13	2 970	50			3 021
14	24 785	3 990	780	8	29 563
15	58 817	12 522	4 678	42	76 059
16	57 358	20 374	12 476	25	90 232
17	42 077	25 922	21 063	1 675	90 737
18	27 022	39 739	25 864	7 539	100 163
19	30 398	68 237	53 936	22 617	175 188
20	73 929	81 520	78 155	70 364	303 969
21	83 149	76 813	44 063	83 172	287 197
22	138 000	150 286	47 139	74 443	409 868
23	320 790	341 570	74 978	98 990	836 329
24	694 654	651 745	101 428	106 529	1554 356
25	1061 909	922 367	116 750	136 928	2237 955
26	1089 212	980 472	102 953	108 083	2280 721
27	903 901	910 138	81 011	86 182	1981 233
28	791 642	742 587	60 964	50 515	1645 708
29	545 013	527 337	43 158	32 438	1147 946
30	390 455	336 165	30 811	21 901	779 331
31	275 719	223 217	18 447	15 442	532 826
32	189 869	122 875	14 777	8 377	335 898
33	108 551	84 113	6 871	3 351	202 886
34	72 104	38 714	2 677	1 675	115 170
35	43 040	18 819	1 897	838	64 594
36	23 417	14 330	791	838	39 376
37	18 358	3 952	948	84	23 342
38	5 096	2 993	1 117	34	9 240
39	5 542	2 572	23	25	8 162
40	3 168	732	39	8	3 947
41	260	649	16		924
42	155	10	8		173
43					
44	147	62			210
45					
46		12			12
47		12			12
48					
49					
50					
TOTAL numbers	7082 394	6404 923	947 831	932 123	15367 271

Table 4.5.4.2 Blue whiting. Landings in numbers ('000) by length group (cm) and quarters for the North Sea and Skagerrak in 2005.

Length	Q1	Q2	Q3	Q4	All year
5					
6					
7			499		499
8					
9					
10					
11					
12					
13		220		174	394
14	84	220		871	1 175
15	1 095	220		7 664	8 979
16	2 053	3 307		14 980	20 340
17	1 052	19 187	499	15 503	36 241
18	1 319	36 648	5 990	8 500	52 457
19	865	48 570	25 957	3 424	78 816
20	1 211	44 373	47 912	5 017	98 513
21	2 825	36 006	59 397	12 629	110 857
22	4 970	51 300	66 881	26 659	149 810
23	4 669	80 886	85 834	29 539	200 928
24	6 066	80 338	93 303	30 485	210 192
25	7 531	58 364	74 338	23 942	164 175
26	5 680	29 881	49 886	20 821	106 268
27	3 628	18 554	26 932	14 350	63 464
28	2 701	9 104	10 478	8 436	30 719
29	1 834	5 980	5 986	6 031	19 831
30	884	2 866	2 488	4 083	10 321
31	647	1 102	1 997	2 271	6 017
32	412	1 102	999	1 394	3 907
33	639	9	485	1 397	2 530
34	252	450		1 047	1 749
35	109	661			770
36	84		499	174	757
37		441			441
38	84				84
39	168				168
40					
41					
42					
43					
44		220			220
45					
46					
47					
48					
49					
50					
TOTAL numbers	50 862	530 009	560 360	239 391	1380 622

Table 4.5.4.3 Blue whiting. Landings in numbers ('000) by length group (cm) and quarters for the Southern area in 2005.

Length	Q1	Q2	Q3	Q4	All year
5					
6					
7					
8					
9					
10					
11					
12					
13					
14					
15		1	34	1	37
16		6	115	71	192
17	1 388	87	201	1 477	3 154
18	2 185	553	254	5 138	8 130
19	2 342	2 211	1 283	4 864	10 700
20	9 012	5 841	3 012	2 743	20 607
21	14 630	14 550	8 465	3 063	40 708
22	12 740	24 033	18 662	7 503	62 937
23	8 875	24 736	21 307	10 553	65 471
24	7 262	16 936	14 277	10 356	48 831
25	6 265	9 304	6 483	8 446	30 498
26	4 803	2 530	2 755	4 196	14 283
27	3 677	1 465	988	2 990	9 120
28	2 961	849	648	1 771	6 230
29	2 181	362	284	1 030	3 856
30	1 081	242	100	429	1 851
31	1 049	166	43	260	1 517
32	445	184	23	48	699
33	221	101	14	26	361
34	116	79	7	6	209
35	54	17	7	4	82
36	32	1		2	35
37	5	1	5	2	12
38	1			1	2
39	1			1	2
40	1				1
41					
42					
43					
44					
45					
46					
47					
48					
49					
50					
TOTAL numbers	81 324	104 257	78 965	64 980	329 527

Table 4.5.4.4 BLUE WHITING. Catch in number (millions) by age group in the directed fisheries (Sub-areas I and II, Divisions Va, and XIVa+b, Vb, VIa+b, VIIb and VIIg-k) in 1993-2005.

Age	1993	1994	1995	1996	1997	1998	1999	2000	2001	2002	2003	2004	2005
0	0	0	1	4	167	15	61	41	119	16	58	6	24
1	37	44	99	497	1352	984	544	912	3459	1111	2464	1132	856
2	130	31	143	327	1079	3535	1180	752	3924	2439	3626	3481	996
3	335	190	338	451	751	3211	5257	3119	2728	2939	7964	6220	4614
4	1348	362	416	425	526	929	3235	4834	3644	2114	4726	6524	5655
5	376	1242	566	248	268	346	362	1517	2474	1804	2006	2972	4304
6	196	294	769	430	238	311	186	500	555	1602	1090	1252	1391
7	108	201	246	619	270	298	143	210	160	336	398	633	506
8	60	103	154	214	391	257	146	144	91	165	119	246	244
9	38	88	58	88	101	209	66	57	69	100	18	74	97
10+	14	32	40	70	164	85	138	139	55	142	27	36	54
Total	2,641	2,588	2,829	3,373	5,307	10,180	11,318	12,225	17,281	12,768	22,495	22,575	18742
Tonnes	389,010	401,378	447,015	493,373	545,058	1,000,870	1,123,317	1,273,123	1,636,683	1,399,659	2,177,047	2,219,296	1,874,932

Table 4.5.4.5 BLUE WHITING. Catch in number (million) by age group in the directed fishery and by-catches from mixed fisheries (Divisions IIIa and IV) for 1993-2005.

Age	1993	1994	1995	1996	1997	1998	1999	2000	2001	2002	2003	2004	2005
0	132	95	3303	812	29	11	60	56	9	190	222	52	46
1	167	33	101	1334	621	576	188	822	770	621	1191	925	496
2	39	21	88	71	269	524	286	317	416	685	369	784	389
3	91	18	29	58	50	259	434	253	174	274	368	405	408
4	97	37	11	71	14	47	168	143	149	105	73	116	196
5	15	6	6	39	14	6	16	22	109	17	18	46	138
6	7	3	11	45	5	4	5	3	29	45	23	12	26
7	8	1	2	33	4	3	5	0	9	8	1	11	11
8	0	1	2	14	6	4	6	7	6	3	1	1	5
9	-	0	1	9	1	4	1	1	8	2	1	1	3
10+	-	-	1	11	2	12	3	1	11	1	1	1	1
Total	556	214	3,555	2,499	1,015	1,450	1,172	1,627	1,689	1,951	2,269	2,355	1720
Tonnes	55,215	28,563	104,004	119,359	65,091	94,881	106,609	114,477	118,523	136,171	153,697	138,593	128,808

Table 4.5.4.6 BLUE WHITING. Catch in number (millions) by age group in the Southern area, 1993-2005.

Age	1993	1994	1995	1996	1997	1998	1999	2000	2001	2002	2003	2004	2005
0	25	13	3	9	11	18	18	32	33	17	7	4	16
1	41	12	96	43	118	97	57	80	134	88	88	84	85
2	146	56	123	131	143	122	82	123	146	108	79	130	141
3	181	149	55	117	86	71	130	93	60	79	47	50	70
4	62	72	38	36	26	69	57	35	14	24	26	10	26
5	12	27	44	33	8	32	35	9	10	4	12	5	12
6	7	9	20	17	4	7	15	10	1	1	4	3	3
7	2	5	6	5	3	2	3	3	0	0	1	1	1
8+	1	4	5	3	3	4	2	0	0	0	1	0	1
Total	477	347	390	394	402	422	399	384	398	321	264	286	355
Tonnes	32,256	29,468	27,664	25,099	30,122	29,400	26,402	24,654	24,964	19,165	16,476	19,680	23,216

Table 4.5.4.7. Blue Whiting: Catch in numbers (thousands) of the total stock in 1982-2005

Age	1982	1983	1984	1985	1986	1987	1988	1989
0								
1	148,000	2,283,000	2,291,000	1,305,000	650,000	838,000	425,000	865,000
2	274,000	567,000	2,331,000	2,044,000	816,000	578,000	721,000	718,000
3	326,000	270,000	455,000	1,933,000	1,862,000	728,000	614,000	1,340,000
4	548,000	286,000	260,000	303,000	1,717,000	1,897,000	683,000	791,000
5	264,000	299,000	285,000	188,000	393,000	726,000	1,303,000	837,000
6	276,000	304,000	445,000	321,000	187,000	137,000	618,000	708,000
7	266,000	287,000	262,000	257,000	201,000	105,000	84,000	139,000
8	272,000	286,000	193,000	174,000	198,000	123,000	53,000	50,000
9	284,000	225,000	154,000	93,000	174,000	103,000	33,000	25,000
10+	673,000	334,000	255,000	259,000	398,000	195,000	50,000	38,000

Age	1990	1991	1992	1993	1994	1995	1996	1997
0				157,000	108,000	3,307,000	825,000	207,000
1	1,611,000	266,686	407,730	263,184	306,951	296,100	1,893,453	2,131,494
2	703,000	1,024,468	653,838	305,180	107,935	353,949	534,221	1,519,327
3	672,000	513,959	1,641,714	621,085	367,962	421,560	632,361	904,074
4	753,000	301,627	569,094	1,571,236	389,264	465,358	537,280	577,676
5	520,000	363,204	217,386	411,367	1,221,919	615,994	323,324	295,671
6	577,000	258,038	154,044	191,241	281,120	800,201	497,458	251,642
7	299,000	159,153	109,580	107,005	174,256	253,818	663,133	282,056
8	78,000	49,431	79,663	64,769	90,429	159,797	232,420	406,910
9	27,000	5,060	31,987	38,118	79,014	59,670	98,415	104,320
10+	95,000	9,570	11,706	17,476	30,614	41,811	82,521	169,235

Age	1998	1999	2000	2001	2002	2003	2004	2005
0	44,000	139,000	129,000	161,000	223,000	287,000	62,606	85,329
1	1,656,926	788,200	1,814,851	4,363,690	1,821,053	3,742,841	2,156,261	1,427,277
2	4,181,175	1,549,100	1,192,657	4,486,315	3,232,244	4,073,497	4,426,323	1,518,938
3	3,541,231	5,820,800	3,465,739	2,962,163	3,291,844	8,378,955	6,723,748	5,083,550
4	1,044,897	3,460,600	5,014,862	3,806,520	2,242,722	4,824,590	6,697,923	5,871,414
5	383,658	412,800	1,550,063	2,592,933	1,824,047	2,035,096	3,044,943	4,450,171
6	322,777	207,200	513,663	585,666	1,647,122	1,117,179	1,276,412	1,419,089
7	303,058	151,200	213,057	170,020	344,403	400,022	649,885	518,304
8	264,105	153,100	151,429	97,032	168,848	121,280	249,097	249,443
9	212,452	68,800	58,277	76,624	102,576	19,701	75,415	100,374
10+	85,513	140,500	139,791	66,410	142,743	27,493	36,805	55,226

Table 4.5.5.1. Blue Whiting: Mean weights-at-age in the total catch and stock in 1982-2005.

Age	1982	1983	1984	1985	1986	1987	1988	1989
0	0.018	0.020	0.026	0.016	0.030	0.023	0.031	0.014
1	0.045	0.046	0.035	0.038	0.040	0.048	0.053	0.059
2	0.072	0.074	0.078	0.074	0.073	0.086	0.076	0.079
3	0.111	0.118	0.089	0.097	0.108	0.106	0.097	0.103
4	0.143	0.140	0.132	0.114	0.130	0.124	0.128	0.126
5	0.156	0.153	0.153	0.157	0.165	0.147	0.142	0.148
6	0.177	0.176	0.161	0.177	0.199	0.177	0.157	0.158
7	0.195	0.195	0.175	0.199	0.209	0.208	0.179	0.171
8	0.200	0.200	0.189	0.208	0.243	0.221	0.199	0.203
9	0.204	0.204	0.186	0.218	0.246	0.222	0.222	0.224
10+	0.231	0.228	0.206	0.237	0.257	0.254	0.260	0.253

Age	1990	1991	1992	1993	1994	1995	1996	1997
0	0.034	0.036	0.024	0.028	0.033	0.022	0.018	0.031
1	0.045	0.055	0.057	0.066	0.061	0.064	0.041	0.047
2	0.070	0.091	0.083	0.082	0.087	0.091	0.080	0.072
3	0.106	0.107	0.119	0.109	0.108	0.118	0.102	0.102
4	0.123	0.136	0.140	0.137	0.137	0.143	0.116	0.121
5	0.147	0.174	0.167	0.163	0.164	0.154	0.147	0.140
6	0.168	0.190	0.193	0.177	0.189	0.167	0.170	0.166
7	0.175	0.206	0.226	0.200	0.207	0.203	0.214	0.177
8	0.214	0.230	0.235	0.217	0.217	0.206	0.230	0.183
9	0.217	0.232	0.284	0.225	0.247	0.236	0.238	0.203
10+	0.256	0.266	0.294	0.281	0.254	0.256	0.279	0.232

Age	1998	1999	2000	2001	2002	2003	2004	2005
0	0.033	0.035	0.031	0.038	0.021	0.019	0.026	0.032
1	0.048	0.063	0.057	0.050	0.054	0.049	0.042	0.039
2	0.072	0.078	0.075	0.078	0.074	0.075	0.066	0.068
3	0.094	0.088	0.086	0.094	0.093	0.098	0.089	0.084
4	0.125	0.109	0.104	0.108	0.115	0.108	0.102	0.099
5	0.149	0.142	0.133	0.129	0.132	0.131	0.123	0.113
6	0.178	0.170	0.156	0.163	0.155	0.148	0.146	0.137
7	0.183	0.199	0.179	0.186	0.173	0.168	0.160	0.156
8	0.188	0.193	0.187	0.193	0.233	0.193	0.173	0.166
9	0.221	0.192	0.232	0.231	0.224	0.232	0.209	0.195
10+	0.248	0.245	0.241	0.243	0.262	0.258	0.347	0.217

Table 4.5.6.1 Blue whiting. Length at age composition (cm) of the landings from the main fisheries in 2005.

Age	Norwegian Sea fishery (Subareas I, II and Divisions Va, XI Va,b)	Spawning area fishery (Divisions Vb, VIa,b, VIIb,c)	Directed and mixed fisheries (Division IIIa and Subarea IV)	Southern areas fishery (Subareas VIII and IX, and Divisions VIId,e,g k)
0	18.1	17.7	16.1	18.7
1	20.0	17.3	20.0	19.8
2	23.8	22.6	22.2	22.0
3	25.1	25.1	24.5	23.7
4	26.7	26.6	26.1	25.3
5	28.0	27.9	27.5	27.2
6	30.0	29.9	29.7	28.3
7	31.4	30.9	31.5	30.8
8	32.2	31.5	32.4	30.3
9	32.7	32.9	33.1	29.4
10+	34.4	33.8	38.2	35.1

Table 4.5.7.1. Blue Whiting: natural mortality and proportion of maturation at age. Natural mortality is assumed to be the same in all years. The values for the maturity-ogive were estimated by the 1994 WG (ICES 1995/Assess:7).

Age	0	1	2	3	4	5	6	7	8	9	10+
Proportion of mature	0.00	0.11	0.40	0.82	0.86	0.91	0.94	1.00	1.00	1.00	1.00
Natural mortality	0.20	0.20	0.20	0.20	0.20	0.20	0.20	0.20	0.20	0.20	0.20

Table 4.5.9.1.1. Blue whiting. Age stratified Spanish cpue (not used in the assessment).

Numbers	age							total
	1	2	3	4	5	6	7	
1982								
1983		7196	16392	9311	7476	6326	1718	48419
1984		13710	27286	14845	4836	1755	1750	64182
1985		14573	23823	14126	6256	1232	217	60227
1986		3721	14131	14745	7113	1278	505	41493
1987		25328	13153	6664	2938	1029	166	49278
1988		7778	21473	18436	6391	1300	781	56159
1989		15272	18486	17160	8374	3760	1003	64055
1990		21444	19407	5194	1803	1357	451	49656
1991		15924	15370	4989	2329	1045	440	40097
1992		10007	24235	9671	4316	1194	462	49885
1993		4036	13991	22493	7979	1354	658	50511
1994		543	6066	15917	7474	2990	1055	34045
1995		9090	14409	6833	4551	1990	623	37496
1996		3905	14557	14449	3931	3639	1834	42315
1997		8742	15875	11134	3698	1046	450	40945
1998		5884	13236	9803	10844	5229	1153	46149
1999		2048	10268	20242	9833	6287	3047	51725
2000		6207	15518	13987	5375	1264	1414	43765
2001		16223	16488	6830	1620	1148	162	42471
2002		10520	13725	10265	3385	336	69	38300
2003		9069	10461	6517	3983	1932	737	32699

Table 4.6.1.1. Age and length distribution of blue whiting in the survey by R/Vs “G.O. Sars”, “Atlantniro”, “Celtic Explorer”, “Tridens” and “Magnus Heinason”, west of the British Isles, March-April 2006.

Length (cm)	Age in years (year class)										Num- bers (10 ⁶)	Bio- mass (10 ⁶ kg)	Mean weight (g)	Prop. mature*
	1 2005	2 2004	3 2003	4 2002	5 2001	6 2000	7 1999	8 1998	9 1997	10+ 1996				
15.0 – 16.0	132	0	0	0	0	0	0	0	0	0	132	2	16.8	0
16.0 – 17.0	795	0	0	0	0	0	0	0	0	0	795	15	19.4	0
17.0 – 18.0	971	0	0	0	0	0	0	0	0	0	971	23	23.4	1
18.0 – 19.0	444	28	0	0	0	0	0	0	0	0	472	14	29.5	17
19.0 – 20.0	364	296	0	0	0	0	0	0	0	0	660	24	36.4	48
20.0 – 21.0	288	833	0	0	0	0	0	0	0	0	1121	48	42.9	80
21.0 – 22.0	106	867	106	0	0	0	0	0	0	0	1079	55	50.9	93
22.0 – 23.0	61	558	711	161	0	0	0	0	0	0	1491	85	57.2	100
23.0 – 24.0	0	1164	1964	766	0	0	0	0	0	0	3894	247	63.5	100
24.0 – 25.0	0	806	5184	2275	102	154	0	0	0	0	8520	597	70.1	100
25.0 – 26.0	0	746	10441	8070	1369	210	0	0	0	0	20838	1605	77.0	100
26.0 – 27.0	0	238	7620	7965	2345	957	0	16	0	0	19141	1624	84.9	100
27.0 – 28.0	0	3	4317	8932	3015	658	0	0	0	0	16925	1598	94.4	100
28.0 – 29.0	0	0	1094	6901	2798	1088	49	0	0	0	11931	1279	107	100
29.0 – 30.0	0	0	649	2631	2861	1229	272	0	53	0	7694	923	120	100
30.0 – 31.0	0	0	25	847	1766	913	391	89	0	0	4032	554	137	100
31.0 – 32.0	0	0	86	305	805	995	468	80	0	0	2738	429	157	100
32.0 – 33.0	0	0	0	20	908	516	181	60	0	0	1685	288	171	100
33.0 – 34.0	0	0	0	60	350	322	251	8	0	0	990	206	208	100
34.0 – 35.0	0	0	3	8	274	472	139	8	48	0	952	221	233	100
35.0 – 36.0	0	0	0	0	16	225	331	232	94	0	897	237	264	100
36.0 – 37.0	0	0	0	0	0	221	192	39	43	0	495	140	282	100
37.0 – 38.0	0	0	0	0	0	12	112	113	21	0	259	79	305	100
38.0 – 39.0	0	0	0	0	0	0	54	54	0	0	108	40	373	100
39.0 – 40.0	0	0	0	0	0	0	14	14	0	0	27	8	307	100
40.0 – 41.0	0	0	0	0	0	0	1	61	25	0	88	37	420	100
41.0 – 42.0	0	0	0	0	0	0	0	10	4	0	14	5	356	100
42.0 – 43.0	0	0	0	0	0	0	5	6	5	7	24	8	353	100
TSN (10 ⁶)	3162	5540	32201	38942	16608	7972	2459	791	293	7	107975			
TSB (10 ⁶ kg)	87	329	2598	3603	1896	1104	495	206	73	3	10393			
Mean length (cm)	18.0	22.9	25.8	27.0	28.7	30.0	32.9	35.2	35.2	42.5	26.9			
Mean weight (g)	27.6	59.5	80.7	92.5	114	139	201	260	249	337	96.3			
Condition (g/dm ³)	4.7	5.0	4.7	4.7	4.8	5.1	5.6	6.0	5.7	4.4	4.9			
% mature*	13	97	100	100	100	100	100	100	100	100	97.3			
% of SSB	0	3	25	35	18	11	5	2	1	0				

* Percentage of mature individuals per age or length class

Table 4.6.1.2. Age and length distribution of blue whiting in the survey by R/V "G.O. Sars" west of the British Isles, March-April 2006.

Length (cm)	Age in years (year class)										Numbers (10 ⁶)	Biomass (10 ⁶ kg)	Mean weight (g)	Mature %
	1 2005	2 2004	3 2003	4 2002	5 2001	6 2000	7 1999	8 1998	9 1997	10+ -1996				
15.0 - 16.0	238	0	0	0	0	0	0	0	0	0	238	4	16.3	0
16.0 - 17.0	1636	0	0	0	0	0	0	0	0	0	1636	32	19.4	1
17.0 - 18.0	1104	6	0	0	0	0	0	0	0	0	1111	26	23.0	4
18.0 - 19.0	857	20	0	0	0	0	0	0	0	0	877	23	26.6	16
19.0 - 20.0	458	222	0	0	0	0	0	0	0	0	680	22	31.8	16
20.0 - 21.0	384	535	0	0	0	0	0	0	0	0	919	37	40.7	51
21.0 - 22.0	113	422	27	0	0	0	0	0	0	0	562	26	46.3	65
22.0 - 23.0	103	372	149	48	0	0	0	0	0	0	672	38	56.6	82
23.0 - 24.0	0	814	1142	840	0	0	0	0	0	0	2796	178	63.7	90
24.0 - 25.0	0	619	3533	2135	0	254	0	0	0	0	6540	457	69.8	100
25.0 - 26.0	0	252	6791	8083	1820	229	0	0	0	0	17175	1314	76.5	100
26.0 - 27.0	0	577	3328	8573	2551	1549	0	0	0	0	16578	1390	83.8	100
27.0 - 28.0	0	0	2689	7740	3683	1025	0	0	0	0	15137	1410	93.2	100
28.0 - 29.0	0	0	895	5446	2862	1600	4	0	0	0	10806	1136	105	100
29.0 - 30.0	0	0	813	2239	2357	1217	401	0	0	0	7027	832	118	100
30.0 - 31.0	0	0	0	867	1408	873	352	156	0	0	3656	489	134	100
31.0 - 32.0	0	0	79	487	328	890	288	0	0	0	2072	299	144	100
32.0 - 33.0	0	0	0	10	845	279	244	17	0	0	1395	231	165	100
33.0 - 34.0	0	0	0	143	90	49	241	264	0	0	786	153	194	100
34.0 - 35.0	0	0	0	7	55	0	42	29	89	0	221	47	214	100
35.0 - 36.0	0	0	0	0	0	201	6	0	7	0	214	48	225	100
36.0 - 37.0	0	0	0	0	0	0	14	0	32	32	78	16	211	100
37.0 - 38.0	0	0	0	0	0	0	0	0	2	8	10	3	248	100
38.0 - 39.0	0	0	0	0	0	0	0	0	0	0	0	0	.	.
39.0 - 40.0	0	0	0	0	0	0	0	0	0	0	0	0	.	.
40.0 - 41.0	0	0	0	0	0	0	0	0	0	0	0	0	.	.
41.0 - 42.0	0	0	0	0	0	0	0	0	0	0	0	0	.	.
42.0 - 43.0	0	0	0	0	0	0	0	0	0	35	35	12	356	100
TSN (10 ⁶)	4893	3839	19446	36617	15998	8167	1592	466	129	75	91221			
TSB (10 ⁶ kg)	125	232	1577	3326	1677	917	240	81	26	21	8221			
Length (cm)	17.9	23.2	26	27	28.3	28.8	31.4	32.5	35.1	39.4	26.6			
Weight (g)	25.5	60.4	81.1	90.8	105	112	151	174	203	281	90.1			
Condition	4.4	4.8	4.6	4.6	4.6	4.7	4.9	5.1	4.7	4.6	4.8			
% mature	10	78	100	100	100	100	100	100	100	100	94.2			
% of SSB	0	2	20	41	21	11	3	1	0	0				

Table 4.6.2.1. Age- and length-stratified abundance estimate of blue whiting in the North-east Atlantic Ecosystem Survey in May–June 2006, west of 20°E. Density is terms of sA-values (m²/nm²) based on combined 5 nm values reported by each of the research vessels “Dana”, “Magnus Heinason”, “Arni Fridriksson”, “Johan Hjort” and “G. O. Sars”.

Length (cm)	1	2	3	4	5	6	7	8	9	10	11	12+	Number	Biomass	Weight
													10 ⁶	10 ⁶	g
16	7	0	0	0	0	0	0	0	0	0	0	0	7	0	18
17	36	0	0	0	0	0	0	0	0	0	0	0	36	1	27
18	345	0	0	0	0	0	0	0	0	0	0	0	345	12	35
19	835	34	0	0	0	0	0	0	0	0	0	0	869	36	41
20	1546	886	0	0	0	0	0	0	0	0	0	0	2432	111	46
21	2747	2338	1	0	0	0	0	0	0	0	0	0	5086	259	51
22	1611	5427	358	0	0	0	0	0	0	0	0	0	7396	433	59
23	335	5947	2717	86	0	0	0	0	0	0	0	0	9085	618	68
24	135	1675	6508	582	0	0	0	0	0	0	0	0	8900	723	81
25	124	643	7186	2189	0	0	0	0	0	0	0	0	10142	892	88
26	52	107	4926	3268	537	17	0	0	0	0	0	0	8907	838	94
27	15	3	1436	4475	235	14	8	0	0	0	0	0	6186	652	105
28	0	1	64	2914	866	10	3	0	1	0	0	0	3859	442	115
29	0	0	1	505	1713	48	5	4	0	0	0	0	2276	298	131
30	0	0	1	78	726	275	4	1	2	0	0	0	1087	159	147
31	0	0	0	3	181	286	21	3	0	0	0	0	494	81	163
32	0	0	0	0	45	147	45	1	0	0	0	1	239	41	172
33	0	0	0	0	17	44	129	36	46	0	0	0	272	54	197
34	0	0	0	0	0	35	44	19	0	0	0	0	98	21	211
35	0	0	0	0	0	7	7	7	0	0	0	0	21	4	224
36	0	0	0	0	0	0	7	7	0	0	0	0	14	3	222
37	0	0	0	0	0	0	1	1	0	0	0	0	2	1	346
38	0	0	0	0	0	0	1	1	0	0	0	0	2	1	272
39	0	0	0	0	0	0	0	0	0	0	0	0	0	0	.
40	0	0	0	0	0	0	0	0	0	0	0	0	0	0	.
41	0	0	0	0	0	0	0	0	0	7	0	0	7	3	401
Number 10 ⁶	7788	17061	23198	14100	4320	883	275	80	49	7	0	1	67762		
Biomass 10 ³ t	403	1086	1989	1437	546	140	52	16	9.5	2.7	0	0.1		5681	
Length cm	21.4	22.9	25.3	27.1	29.1	31.3	33.2	34.0	33.3	41.1		32.5		25.0	
Weight g	51.8	63.6	85.7	102	126	159	189	203	193	393		172		83.8	

Table 4.6.2.2. Blue whiting: Estimated stock biomass, numbers, length and weight at age for blue whiting in the standard survey area (between 8°W-20°E and north of 63°N) in the international surveys 2000–2006.

	Age											Total
	1	2	3	4	5	6	7	8	9	10	11	
Numbers (10⁶)												
2000	48927	3133	3580	1668	201	5						57514
2001	85772	25110	7533	3020	2066							123501
2002	15251	46656	14672	4357	513	445		15		6		81915
2003	35688	21487	35372	4354	639	201	43	3				97787
2004	49254	22086	13292	8290	1495	533	83	39				95072
2005	54660	19904	13828	4714	1886	326	103	43	8	3	11	95486
2006	570	18300	15324	6550	1566	384	246	80	47	2	8	43077
Biomass (10⁶ kg)												
2000	1795	260	335	193	25	1						2608
2001	2735	1776	763	418	322							6014
2002	651	2640	1289	526	76	64		3		2		5250
2003	1475	1539	2897	497	88	31	11	1				6538
2004	1643	1437	1188	886	193	77	13	6				5442
2005	1558	1204	1124	502	233	49	16	8	2	1	2	4699
2006	23	1099	1330	704	198	51	36	12	8	0	2	3463
Length (cm)												
2000	19.2	24.7	25.6	27.3	27.7	33.2						20.2
2001	18.2	23.4	26.3	28.8	29.8							20.2
2002	20.1	21.9	25.1	27.9	30.1	30.2		34.5		37.5		22.5
2003	20.1	23.5	24.5	27.0	28.9	29.9	34.5	33.5				22.8
2004	18.7	22.5	24.8	26.5	28.6	30.1	31.4	30.9				21.4
2005	17.9	22.3	24.3	26.5	28.0	30.3	31.0	32.7	32.7	30.5	38.5	20.4
2006	19.9	22.6	25.0	26.7	28.2	28.7	29.6	30.0	31.2	30.5	32.5	24.3
Weight (g)												
2000	37	83	94	116	122	225						45.3
2001	32	71	101	138	156							48.7
2002	43	57	88	121	147	145		210		269		64.1
2003	41	72	82	114	138	153	256	219				66.9
2004	33	65	89	107	129	144	162	160				57.2
2005	29	62	83	108	126	155	164	197	190	158	222	49.9
2006	40	60	87	108	126	134	145	150	172	156	184	80.4

Table 4.6.4.1 Age stratified acoustic survey estimates of blue whiting in the Norwegian Sea in July-August. Numbers in millions.

Year\Age	1	2	3	4	5	6	7	8	9	Total
1981	182	728	4542	3874	2678	2834	2964	2756	2054	22612
1982	184	460	1242	4715	3611	3128	2323	1679	874	18216
1983	22356	396	468	756	1404	576	468	432	324	27180
1984	30380	13916	833	392	539	539	343	49	49	47040
1985	5969	23876	12502	658	423	188	235	141	376	44368
1986	2324	2380	7224	6944	1876	952	336	308	140	22484
1987	8204	4032	5180	5572	1204	224	168	56	84	24724
1988	4992	2880	2640	3480	912	120	96	24	48	15192
1989	1172	1125	812	379	410	212	22	32		4164
1990	no survey									
1991	no survey									
1992	792	1134	6939	766	247	172	90	11	18	10169
1993	830	125	1070	6392	1222	489	248	58	88	10522
1994	no survey									
1995	6974	2811	1999	1209	1622	775	173	61		15624
1996	23464	1057	899	649	436	505	755	69	41	27875
1997	30227	25638	1524	779	300	407	260	137	123	59395
1998	24244	47815	16282	556	212	100	64	10	255	89538
1999	14367	9750	23701	9754	1733	466	79	48	91	59989
2000	25813	3298	2721	3078	23	46	6			34985
2001	61470	22051	7883	3225	1824	156	12		68	96689
2002	no survey									

Table 4.6.6.1 Stratified mean catch (Kg/haul and Number/haul) and standard error of BLUE WHITING in bottom trawl surveys in Spanish waters (Divisions VIIIc and IXa north). All surveys in September-October.

Kg/haul Year	30-100 m		101-200 m		201-500 m		TOTAL 30-500 m	
	Mean	SD	Mean	SD	Mean	SD	Mean	SD
1985	9.50	5.87	119.75	45.99	68.18	13.79	92.83	28.24
1986	9.74	7.13	45.41	12.37	29.54	8.70	36.93	7.95
1987	-	-	-	-	-	-	-	-
1988	2.90	2.59	154.12	38.69	183.07	141.94	143.30	45.84
1989	14.17	12.03	76.92	17.08	18.79	6.23	59.00	11.68
1990	6.25	3.29	52.54	9.00	18.80	4.99	43.60	6.60
1991	64.59	34.65	126.41	26.06	46.07	18.99	97.10	17.16
1992	6.37	2.59	44.12	6.64	29.50	6.16	34.60	4.23
1993	1.06	0.63	14.07	3.73	51.08	22.02	22.59	6.44
1994	8.04	5.28	37.18	8.45	25.42	5.27	29.70	5.19
1995	19.97	13.87	36.43	4.82	15.97	4.10	28.52	3.66
1996	7.27	3.95	49.23	7.19	92.54	17.76	54.52	6.36
Kg/haul Year	70-120 m		121-200 m		201-500 m		TOTAL 70-500 m	
	Mean	SD	Mean	SD	Mean	SD	Mean	SD
1997	17.87	7.35	44.68	10.52	57.14	16.60	42.62	7.29
1998	14.13	4.17	42.78	8.13	78.88	22.01	47.14	7.58
1999	93.01	14.60	112.39	19.92	169.21	50.26	124.66	17.85
2000	62.39	12.00	91.99	14.75	58.72	24.94	76.19	10.61
2001	8.35	3.31	50.18	10.09	52.41	16.71	42.02	7.02
2002	31.40	5.02	69.00	13.41	36.75	12.07	51.80	7.64
2003	42.52	12.22	71.40	11.01	46.43	11.42	58.13	6.92
2004	2.80	2.11	14.05	7.79	59.51	21.41	24.76	7.31
2005	50.63	16.15	95.17	19.28	40.06	8.88	69.94	10.57

Number/haul Year	30-100 m		101-200 m		201-500 m		TOTAL 30-500 m	
	Mean	SD	Mean	SD	Mean	SD	Mean	SD
1985	267	181.71	3669	1578.86	1377	262.98	2644	963.20
1986	368	237.56	2486	1006.67	752	238.87	1763	616.40
1987	-	-	-	-	-	-	-	-
1988	83	71.74	6112	1847.36	7276	6339.88	5694	2086.00
1989	629	537.29	3197	876.75	566	213.11	2412	599.00
1990	220	115.48	2219	426.46	578	185.43	1722	276.00
1991	2922	1645.73	5563	1184.69	1789	847.33	4214	780.88
1992	124	50.81	1412	233.99	845	199.12	1069	146.87
1993	14	8.61	257	69.61	894	427.77	401	124.53
1994	346	234.12	2002	456.50	997	245.91	1487	689.00
1995	1291	864.97	2004	341.48	485	137.81	1493	240.37
1996	147	82.71	1167	167.20	2097	385.23	1263	142.30
Kg/haul Year	70-120 m		121-200 m		201-500 m		TOTAL 30-500 m	
	Mean	SD	Mean	SD	Mean	SD	Mean	SD
1997	552	235.60	1443	361.89	1183	323.14	1180	209.94
1998	351	105.96	1463	320.26	2012	590.04	1387	234.82
1999	2508	427.20	4388	849.80	6119	2026.40	4490	727.90
2000	2267	414.97	3930	604.11	2009	859.71	3027	400.87
2001	171	77.34	1310	263.84	1232	381.49	1048	172.74
2002	771	90.34	2526	499.30	1075	331.09	1739	268.70
2003	1320	384.25	2791	554.16	1513	454.02	2114	317.68
2004	31	22.77	336	154.33	1472	736.78	599	225.74
2005	1141	504.13	3874	944.57	1102	292.20	2564	492.91

Table 4.6.7.1 Blue whiting stratified mean catch (kg/haul) and standard error of bottom trawl surveys in Portuguese waters (Divisio IXa)

Year	Month	20-100 m		100-200 m		200-500 m		500-750 m		TOTAL	
		y	sy	y	sy	y	sy	y	sy	y	sy
1990	July	2	2	153	103	242	42	50	5	96	35
	October	11	5	90	28	762	234	42	10	153	35
1991	July	1	1	140	40	268	38	64	18	98	15
	October	8	5	83	18	259	53	121	27	91	11
1992	February	7	7	43	35	249	21	73	3	68	12
	July	1	1	29	18	216	43	27	5	47	9
	October	1	1	22	7	208	44	80	3	54	7
1993	February	0	0	19	14	105	31	36	0	42	10
	July	0	0	3	3	151	28	55	5	34	4
	November	0	0	90	0	189	43	6	1	86	9
1994	October	0	0	374	30	283	32	49	7	174	11
1995	July	0	0	18	14	130	20	52	3	35	5
	October	18	15	103	21	328	91	31	12	94	16
1996	October	25	24	12	2	36	6	25	7	22	8
1997	June	0	0	3	3	116	42	45	12	27	7
	October	2	1	54	20	77	13	7	2	32	8
1998	July	0	0	8	5	105	17	38	3	25	3
	October	1	1	384	87	427	101	20	2	212	36
1999	July	1	0	60	21	66	19	25	2	37	9
	October	0	0	69	16	80	20	18	8	41	7
2000	July	23	13	109	34	116	10	63	6	75	13
	October	11	4	155	53	196	22	54	4	99	19
2001	July	18	7	238	37	305	116	57	14	152	23
	October	106	6	474	224	294	66		0	295	97
2002	October	19	12	176	81	180	24		0	116	34
2003	October	24	10	114	14	119	30	34	6	76	8
2004	October	0	0	44	10	380	27			84	15

Table 4.6.8.1 Catch in number of 1-group (age 1) blue whiting from the spring (March) bottom trawl surveys on the Faroe plateau 1996-2005. The number of 1-group in 2004 was taken out by age readings while for other years they were taken out from a visual inspection of the length distributions. There was a clear separation of the 1 and 2-group in the data (see Table 6.4.2.3).

Year	1-group
1994	1388
1995	1171
1996	4442
1997	1239
1998	262
1999	1108
2000	782
2001	2058
2002	3885
2003	873
2004	13016
2005	22653

Table 4.6.8.2 Length distribution (cm) of blue whiting from the spring (March) bottom trawl surveys on the Faroe plateau 1994-2005. Shaded areas in the years 1994-2005 indicate 1-group fish separated from visual inspection of the length distributions (in lack of otolith samples from the catch). In 2004 the 1-group was separated by age readings from the survey.

Length	Year											
	1994	1995	1996	1997	1998	1999	2000	2001	2002	2003	2004	2005
10	0	0	0	0	0	0	0	0	0	0	0	0
11	0	0	0	1	0	0	0	0	0	0	0	0
12	0	0	0	0	0	0	0	0	0	0	0	0
13	0	0	18	12	0	0	0	0	0	0	0	0
14	0	0	107	149	0	0	0	11	0	0	159	512
15	0	0	702	347	0	5	1	68	0	0	1285	2402
16	1	8	865	207	6	92	51	289	0	16	3508	5617
17	25	0	585	303	31	178	126	356	124	303	3106	5212
18	198	53	669	141	72	263	133	398	262	249	2035	4498
19	442	146	567	79	64	317	200	439	553	162	1932	2244
20	399	111	539	132	45	200	137	230	1050	46	1005	1302
21	271	446	250	130	44	53	88	267	843	97	589	866
22	46	341	140	263	98	222	46	1299	1053	56	1544	1097
23	6	66	164	331	157	386	105	2235	1120	377	1471	853
24	0	112	793	356	183	623	221	2348	1047	472	2401	1536
25	0	224	1051	139	179	1022	312	2664	1859	856	2462	2512
26	0	291	1456	94	136	1259	668	2687	2670	602	3909	3394
27	8	194	841	82	93	789	1049	2493	4125	691	3100	2140
28	4	89	548	61	57	529	1148	2954	4564	240	2659	1698
29	5	49	195	93	48	314	1105	1774	5014	184	2080	1530
30	23	27	159	16	28	105	939	731	4852	229	965	1862
31	36	28	108	38	43	140	549	526	2924	126	1311	998
32	43	176	65	30	63	114	434	94	1899	90	754	417
33	48	79	112	32	12	96	361	201	1812	18	452	610
34	15	154	159	40	26	61	196	140	928	32	233	555
35	24	252	74	14	33	63	172	158	341	9	282	118
36	40	134	134	45	20	2	149	101	418	0	22	284
37	40	201	127	58	14	50	126	40	253	0	52	16
38	31	230	27	41	6	33	47	2	61	0	9	0
39	31	107	19	0	8	12	16	0	126	0	0	0
40	16	93	29	3	0	0	17	0	0	0	0	0
41	7	12	12	0	0	12	15	0	0	0	0	0
42	2	0	0	0	0	16	0	0	0	0	0	0
43	0	0	0	0	0	0	0	0	0	0	0	0
44	0	0	0	0	0	0	0	0	0	0	0	0
45	0	0	0	0	0	0	0	0	0	0	0	0
Sum	1761	3623	10515	3237	1466	6956	8411	22505	37898	4855	37325	42273
1-group	1388	1171	4442	1239	262	1108	782	2058	3885	873	13016	22653

Table 4.6.9.1. Blue whiting, 1-group index from the Icelandic bottom trawl survey in March.

year	age1 index
1996	6.055
1997	2.803
1998	0.903
1999	5.308
2000	9.139
2001	4.902
2002	12.243
2003	14.142
2004	7.423
2005	6.326
2005	6.326
2006	31.300

Table 4.6.12.1 Catch in number by age of blue whiting from the summer (August/September) bottom trawl surveys on the Faroe plateau 1996-2004. Icelandic age readings from June-August) were used to split the numbers by age.

Year	Age													Total
	0	1	2	3	4	5	6	7	8	9	10	11	12	
1996	12513	18586	4576	5392	6754	2755	1610	768	352	337	121	2	34	53802
1997	4139	20745	13710	8345	5748	2488	1376	619	242	179	95	2	14	57701
1998	2359	21202	28278	19217	12289	4143	2330	1057	358	301	126	4	27	91690
1999	7322	4189	4468	12725	19609	6041	791	524	344	284	139	0	18	56452
2000	11120	85876	18307	18875	42059	10892	2557	584	270	400	316	0	0	191254
2001	17431	65857	49449	16099	25119	9486	3362	1295	420	134	0	0	0	188652
2002	1113	12348	10026	7112	5623	5724	3616	1577	448	508	0	0	0	48095
2003	60646	18043	17338	21706	12578	4791	3701	1424	357	49	0	9	0	140641
2004	35744	18243	10222	16912	20938	6887	823	550	287	315	137	0	76	111133

Table 4.6.14.1. Abundance index on blue whiting in the Norwegian winter survey (late January to early March) in the Barents Sea. Blue whiting <18cm in total body length most likely belong to 1-group.

Year		1981	1982	1983	1984	1985	1986	1987	1988	1989	1990	1991	1992	1993
Catch rate (ind./nm)	All	0.10	0.24	5.41	7.66	38.3	24.2	11.8	6.57	1.88	18.4	56.1	34.2	8.22
	≤18cm	0.00	0.01	0.73	2.48	0.87	1.14	0.02	0.63	0.20	17.0	2.3	0.05	0.01

Year		1994	1995	1996	1997	1998	1999	2000	2001	2002	2003	2004	2005	2006
Catch rate (ind./nm)	All	3.7	1.9	23.3	220.7	20.2	8.1	106.3	396.0	119.6	70.4	171.1	225.2	296.4
	≤18cm	0.00	0.10	14.21	184.86	2.05	0.43	92.27	270.05	6.14	22.32	42.68	87.41	2.11

Table 4.6.15.1 Blue whiting egg number and development stages in the samples west of British Isles observed by R/V Atlantnir March 2006.

Longitude	Latitude	nos. egg/m ²	1+2	3+4	5	6
16.22	54.07	2			2	
17.99	54.06	0				
16.00	54.36	2		2		
16.99	54.37	8	6	2		
18.99	54.38	0				
15.73	55.09	4	4			
17.99	55.07	44	2	6	36	
17.45	55.23	6928	3288	56	3376	208
15.98	55.37	26	10		14	2
17.49	55.53	1220	452	18	728	22
17.00	56.07	1636	592	14	954	76
18.68	56.09	678	234	10	410	24
15.33	56.23	46			46	
16.02	56.38	2			2	
18.01	56.38	4			2	2
14.86	57.08	24	12	4	8	
17.03	57.07	6	4		2	
19.03	57.07	14	4		10	
16.01	57.32	52	8		44	
16.99	57.37	38	32		6	
18.00	57.38	30	4	4	22	
15.19	58.08	64	10	12	42	
17.01	58.08	10		4	6	
17.99	58.07	4	4			
14.92	58.38	4038	976	164	2406	492
15.99	58.37	768	304	18	414	32
14.76	59.07	852	362	14	448	28
Total		16500	328	8978	886	6308

Table 4.7.2.1. Blue whiting. Summary of the AMCI assessment. Values for 2006–2007 depend on assumptions on fisheries in 2006-2007 (F=F status quo in 2005).

Year	Recruits age 1 (1000s)	SSB (tonnes)	F 3-7yr (yr-1)	Catch SOP (tonnes)	Modelled catch (tonnes)
1981	3639011	2839869	0.3108	922980	897882
1982	4080466	2339909	0.2278	550643	550010
1983	10893564	1903957	0.2612	553344	557856
1984	18345567	1548796	0.3417	615569	606202
1985	12230128	1652340	0.3867	678214	656214
1986	9475096	1856063	0.5238	847145	845758
1987	8992228	1655867	0.4621	654718	672991
1988	7701344	1469908	0.4308	552264	546842
1989	8969960	1414358	0.5066	630316	623012
1990	22344038	1338728	0.4957	558128	583207
1991	9060445	1808037	0.2212	364008	347384
1992	6207546	2444828	0.2239	474592	456501
1993	5566925	2395147	0.2089	475198	450275
1994	6583893	2367013	0.1951	457696	446715
1995	7685479	2195601	0.2318	505175	513613
1996	20600285	2037709	0.3024	621104	631699
1997	38863728	2077667	0.3086	639680	652512
1998	31623362	2827798	0.4394	1131954	1093494
1999	21790165	3440207	0.4062	1261033	1175705
2000	42902242	3641046	0.4676	1412449	1414242
2001	71818287	4228551	0.4878	1771805	1754003
2002	45799835	5371280	0.4089	1556954	1752316
2003	50292809	6688660	0.4168	2365319	2222895
2004	36249403	6384099	0.4567	2400794	2359338
2005	47844044	6072860	0.3927	2018344	1973500
2006		5913276	0.3927		1961813
2007		5244596			1776602

Table 4.7.3.1. BW. Results of TISVPA stock assessment

	R(1)	B(1+)	SSB (Jan.1)	SSB (sp.time)	F(3-7)
1981	3677	4244.0	3712.4	3272.6	0.238
1982	4402	3281.9	2804.7	2521.8	0.185
1983	16829	2998.7	2018.4	1789.2	0.217
1984	18920	3019.3	1762.8	1555.6	0.272
1985	11013	3254.9	2082.7	1829.1	0.336
1986	8308	3413.3	2469.6	2103.5	0.495
1987	8507	2982.2	2048.3	1766.2	0.397
1988	6954	2511.7	1698.3	1471.9	0.518
1989	9202	2524.2	1605.7	1389.6	0.523
1990	20742	2815.5	1543.8	1333.8	0.498
1991	8984	3377.1	1925.7	1755.9	0.264
1992	6563	3552.3	2519.2	2294.3	0.184
1993	5990	3346.5	2442.8	2220.9	0.208
1994	6945	3275.8	2411.4	2182.0	0.206
1995	8937	3254.6	2244.8	2004.2	0.253
1996	24178	3504.3	2128.7	1875.6	0.312
1997	41280	5059.1	2371.8	2122.5	0.281
1998	29326	6200.5	3258.2	2858.0	0.419
1999	23983	6781.3	3895.6	3446.6	0.368
2000	39130	7385.5	4060.5	3518.9	0.520
2001	60789	9109.1	4538.2	3992.1	0.482
2002	46873	10367.4	5499.5	4775.6	0.477
2003	37621	10679.3	6555.3	5772.3	0.503
2004	13967	8360.2	5944.0	5097.2	0.634
2005	13157	6191.9	4708.3	3935.7	0.608
2006			3279.2	2707.1	

Table 4.7.3.2. BW. TISVPA estimates of abundance

	1	2	3	4	5	6	7	8	9	10+
1981	3677.05	4095.72	4981.92	3299.03	2418.68	2250.82	1983.37	2185.88	1992.90	5033.97
1982	4402.41	2800.95	3047.31	3496.67	2356.13	1494.38	1326.85	1196.54	1216.00	2881.57
1983	16829.21	3446.20	2088.38	2186.83	2409.58	1688.91	956.32	839.36	731.21	1085.43
1984	18919.69	12091.94	2436.89	1440.56	1450.32	1620.92	1111.25	534.98	433.50	717.80
1985	11012.90	13768.56	8067.04	1594.20	902.27	882.04	937.07	689.78	256.87	715.38
1986	8308.20	8075.51	9614.12	4738.02	987.86	541.60	457.33	537.57	408.02	933.30
1987	8507.08	6277.45	5790.07	5887.90	2165.41	498.88	267.28	210.37	258.20	488.82
1988	6953.76	6273.17	4642.96	3848.14	3125.82	991.95	264.69	130.41	81.98	124.21
1989	9202.14	5288.93	4471.73	3204.34	2330.70	1497.50	321.48	135.32	57.76	87.80
1990	20741.54	6818.23	3761.91	2612.71	1959.11	1193.50	611.54	110.57	58.67	206.43
1991	8983.88	15311.48	4890.14	2436.04	1405.30	1147.21	507.19	234.14	19.53	36.77
1992	6562.75	7023.21	11508.82	3498.59	1690.74	861.98	737.99	291.98	132.43	48.42
1993	5989.51	5054.30	5240.40	7987.17	2370.27	1167.95	547.60	501.49	168.99	77.62
1994	6945.21	4696.91	3860.00	3739.65	5237.85	1590.73	781.15	347.70	340.14	131.75
1995	8936.72	5441.79	3692.71	2794.61	2611.81	3301.03	1039.23	500.77	203.43	142.43
1996	24178.27	6949.51	4144.61	2650.80	1833.29	1605.15	1910.42	623.27	280.16	234.89
1997	41279.95	18165.94	5136.72	2863.92	1721.82	1137.12	866.19	970.69	310.27	503.33
1998	29326.28	31627.57	13377.72	3408.91	1870.48	1132.06	665.92	466.75	443.21	178.33
1999	23982.96	22131.04	22126.10	7858.58	1822.04	1126.83	620.41	289.04	160.19	327.14
2000	39129.68	18559.77	16315.10	13444.18	3910.09	1030.83	678.45	359.06	114.11	273.62
2001	60789.01	29604.04	13696.55	10076.23	6759.83	1814.92	414.66	354.70	161.97	140.39
2002	46873.41	45813.30	20657.46	8754.08	5314.13	3352.26	846.24	184.76	183.07	254.62
2003	37621.23	35912.88	33426.96	12945.14	4972.04	2621.13	1287.71	326.04	39.12	545.94
2004	13966.85	27406.99	25987.40	20693.06	6741.13	2554.45	1187.74	598.87	120.11	58.61
2005	13157.17	9751.46	18227.29	15777.98	10878.30	2941.75	1059.78	427.28	172.01	94.62
2006		9480.72	6609.43	10323.41	7605.25	4879.69	1124.45	398.70	124.16	49.98

Table 4.7.3.3. BW. TISVPA estimates of fishing mortality

	1	2	3	4	5	6	7	8	9	10+
1981	0.0807	0.0986	0.1638	0.1187	0.2882	0.3209	0.3007	0.3865	0.3864	0.3864
1982	0.0379	0.1144	0.1258	0.1902	0.1322	0.2283	0.2505	0.2893	0.2986	0.2986
1983	0.1624	0.2007	0.1542	0.1561	0.1475	0.2218	0.4030	0.4725	0.4156	0.4156
1984	0.1437	0.2396	0.2311	0.2225	0.2449	0.3616	0.3019	0.5087	0.4986	0.4986
1985	0.1404	0.1792	0.3076	0.2358	0.2617	0.5145	0.3611	0.3268	0.5110	0.5110
1986	0.0904	0.1184	0.2409	0.5117	0.5792	0.4806	0.6650	0.5227	0.6373	0.6373
1987	0.1153	0.1073	0.1496	0.4402	0.4629	0.3617	0.5695	1.0389	0.5814	0.5814
1988	0.0699	0.1358	0.1580	0.2184	0.6175	1.1665	0.4319	0.5963	0.5886	0.5886
1989	0.1097	0.1626	0.4022	0.3186	0.5057	0.7392	0.6498	0.5249	0.6507	0.6507
1990	0.0898	0.1210	0.2199	0.3835	0.3472	0.7642	0.7773	1.5123	0.7105	0.7105
1991	0.0334	0.0768	0.1235	0.1471	0.3364	0.2857	0.4260	0.2655	0.3405	0.3405
1992	0.0711	0.1086	0.1716	0.1982	0.1533	0.2200	0.1793	0.3591	0.3107	0.3107
1993	0.0498	0.0691	0.1404	0.2451	0.2130	0.1996	0.2433	0.1541	0.2866	0.2866
1994	0.0501	0.0257	0.1113	0.1222	0.2982	0.2173	0.2832	0.3387	0.2966	0.2966
1995	0.0373	0.0746	0.1349	0.2034	0.3020	0.3118	0.3146	0.4349	0.3921	0.3921
1996	0.0905	0.0888	0.1847	0.2536	0.2168	0.4194	0.4839	0.5312	0.4913	0.4913
1997	0.0588	0.0970	0.2163	0.2522	0.2105	0.2804	0.4462	0.6223	0.4645	0.4645
1998	0.0645	0.1580	0.3461	0.4136	0.2571	0.3785	0.6992	0.9817	0.7548	0.7548
1999	0.0370	0.0805	0.3435	0.6668	0.2882	0.2272	0.3138	0.8804	0.6437	0.6437
2000	0.0526	0.0737	0.2676	0.5315	0.5765	0.8002	0.4264	0.6274	0.8316	0.8316
2001	0.0827	0.1833	0.2732	0.5404	0.5515	0.4411	0.6036	0.3600	0.7398	0.7398
2002	0.0439	0.0812	0.1937	0.3329	0.4770	0.7831	0.5974	4.6335	0.9659	0.9659
2003	0.1165	0.1339	0.3244	0.5309	0.6021	0.6369	0.4205	0.5296	0.8130	0.8130
2004	0.1856	0.1950	0.3339	0.4387	0.6844	0.7946	0.9172	0.6095	1.1655	1.1655
2005	0.1277	0.1889	0.3685	0.5298	0.6017	0.7617	0.7776	1.0358	1.0358	1.0358

Table 4.7.3.4. BW. Results for restricted data

	R(1)	B(1+)	SSB (Jan.1)	SSB (sp.time)	F(3-7)
1981	3677	31900.2	4240.5	3708.9	0.239
1982	4402	24208.3	3279.7	2802.5	0.185
1983	16828	32255.5	2997.7	2017.5	0.217
1984	18918	40753.5	3018.8	1762.3	0.272
1985	11010	38821.5	3254.4	2082.3	0.336
1986	8306	34596.5	3412.8	2469.2	0.495
1987	8504	30346.1	2981.8	2048.0	0.397
1988	6952	26432.3	2511.3	1698.1	0.518
1989	9201	26593.7	2523.9	1605.5	0.523
1990	20737	38068.1	2815.2	1543.6	0.498
1991	8983	34969.7	3377.0	1925.7	0.264
1992	6562	32356.3	3552.3	2519.1	0.184
1993	5991	29107.5	3346.7	2442.9	0.208
1994	6947	27675.8	3276.2	2411.7	0.206
1995	8935	28667.8	3255.1	2245.2	0.253
1996	24182	44417.1	3504.9	2129.2	0.312
1997	41306	72989.3	5061.1	2372.5	0.281
1998	29389	82587.2	6205.8	3259.8	0.419
1999	24113	80647.1	6795.7	3900.0	0.368
2000	39419	94267.6	7415.5	4070.2	0.520
2001	61652	125042.6	9184.1	4561.6	0.481
2002	47900	134262.6	10506.2	5553.0	0.474
2003	38595	132317.1	10874.8	6657.6	0.496
2004	14404	101887.0	8565.4	6082.0	0.617
2005	13651	75088.1	6412.5	4875.2	0.579
2006			4247.1	3464.4	

Table 4.7.3.5 BW. Estimateds of abundance for restricted data

	1	2	3	4	5	6	7	8	9	10+
1981	3677.17	4095.37	4981.38	3298.10	2418.11	2249.86	1981.77	2183.71	1989.46	5025.27
1982	4402.32	2801.19	3047.06	3496.30	2355.39	1493.97	1326.11	1195.23	1213.97	2876.77
1983	16827.76	3446.27	2088.55	2186.66	2409.28	1688.32	955.98	838.73	730.10	1083.79
1984	18917.77	12091.91	2436.95	1440.69	1450.21	1620.70	1110.77	534.68	432.92	716.86
1985	11010.34	13768.11	8067.04	1594.27	902.35	882.01	936.90	689.37	256.57	714.53
1986	8306.14	8074.06	9613.68	4738.21	987.91	541.66	457.32	537.40	407.65	932.43
1987	8504.38	6276.24	5788.99	5887.74	2165.71	498.96	267.31	210.35	258.00	488.45
1988	6951.78	6271.70	4642.06	3847.49	3125.72	992.28	264.74	130.41	81.94	124.15
1989	9200.72	5287.90	4470.77	3203.80	2330.37	1497.57	321.71	135.34	57.74	87.76
1990	20736.94	6817.99	3761.31	2612.33	1958.81	1193.41	611.59	110.66	58.66	206.39
1991	8982.66	15310.72	4890.36	2435.97	1405.29	1147.12	507.18	234.12	19.52	36.75
1992	6562.40	7022.81	11508.72	3498.99	1690.77	862.02	737.91	291.94	132.37	48.40
1993	5990.95	5054.34	5240.26	7987.68	2370.69	1168.03	547.61	501.39	168.92	77.59
1994	6947.34	4698.30	3860.12	3739.77	5238.57	1591.13	781.21	347.68	340.01	131.70
1995	8935.22	5443.77	3693.91	2794.84	2612.08	3301.83	1039.55	500.80	203.36	142.39
1996	24181.54	6948.76	4146.28	2651.91	1833.57	1605.52	1911.09	623.46	280.11	234.85
1997	41306.09	18169.85	5136.23	2865.42	1722.83	1137.47	866.55	971.11	310.31	503.39
1998	29388.52	31649.15	13380.90	3408.77	1871.80	1132.97	666.25	467.02	443.39	178.40
1999	24112.94	22183.13	22140.94	7861.54	1822.28	1128.04	621.21	289.28	160.32	327.40
2000	39418.61	18666.54	16357.05	13454.02	3912.74	1031.29	679.48	359.69	114.25	273.97
2001	61652.41	29840.38	13782.85	10109.84	6765.82	1817.40	415.19	355.51	162.42	140.78
2002	47899.81	46517.62	20848.72	8824.14	5341.38	3357.68	848.71	185.27	183.73	255.54
2003	38595.21	36746.94	33995.64	13098.59	5027.64	2642.50	1292.36	328.03	39.47	550.74
2004	14404.13	28201.06	26666.57	21157.58	6867.02	2599.68	1205.64	603.84	121.97	59.52
2005	13650.97	10099.72	18878.08	16337.04	11263.46	3044.88	1096.43	441.79	177.85	97.84
2006	0.00	9885.01	6894.56	10856.23	8062.98	5195.03	1208.88	428.70	136.04	54.77

Table 4.7.3.6 BW. Estimates of F for restricted data

	1	2	3	4	5	6	7	8	9	10+
1981	0.0807	0.0986	0.1638	0.1187	0.2883	0.3210	0.3009	0.3869	0.3873	0.3873
1982	0.0379	0.1144	0.1258	0.1902	0.1322	0.2284	0.2506	0.2897	0.2991	0.2991
1983	0.1624	0.2007	0.1542	0.1561	0.1475	0.2219	0.4032	0.4730	0.4164	0.4164
1984	0.1437	0.2396	0.2311	0.2225	0.2449	0.3616	0.3020	0.5090	0.4994	0.4994
1985	0.1404	0.1792	0.3076	0.2358	0.2617	0.5145	0.3612	0.3271	0.5118	0.5118
1986	0.0905	0.1184	0.2409	0.5116	0.5792	0.4805	0.6650	0.5229	0.6382	0.6382
1987	0.1153	0.1073	0.1496	0.4402	0.4628	0.3616	0.5694	1.0391	0.5820	0.5820
1988	0.0700	0.1359	0.1580	0.2184	0.6175	1.1657	0.4318	0.5963	0.5890	0.5890
1989	0.1097	0.1626	0.4023	0.3186	0.5058	0.7392	0.6492	0.5247	0.6511	0.6511
1990	0.0898	0.1210	0.2200	0.3836	0.3473	0.7643	0.7772	1.5096	0.7107	0.7107
1991	0.0334	0.0768	0.1235	0.1472	0.3364	0.2858	0.4260	0.2655	0.3407	0.3407
1992	0.0711	0.1086	0.1716	0.1982	0.1533	0.2200	0.1793	0.3591	0.3108	0.3108
1993	0.0498	0.0691	0.1404	0.2451	0.2129	0.1996	0.2433	0.1541	0.2867	0.2867
1994	0.0501	0.0257	0.1113	0.1222	0.2981	0.2172	0.2831	0.3388	0.2968	0.2968
1995	0.0373	0.0746	0.1348	0.2034	0.3020	0.3118	0.3145	0.4349	0.3922	0.3922
1996	0.0905	0.0888	0.1846	0.2535	0.2168	0.4193	0.4836	0.5310	0.4914	0.4914
1997	0.0587	0.0970	0.2163	0.2521	0.2103	0.2803	0.4459	0.6219	0.4644	0.4644
1998	0.0643	0.1578	0.3460	0.4137	0.2569	0.3782	0.6987	0.9808	0.7543	0.7543
1999	0.0368	0.0803	0.3433	0.6665	0.2882	0.2269	0.3133	0.8792	0.6430	0.6430
2000	0.0522	0.0732	0.2668	0.5309	0.5760	0.7996	0.4256	0.6258	0.8300	0.8300
2001	0.0815	0.1817	0.2712	0.5381	0.5509	0.4403	0.6025	0.3590	0.7368	0.7368
2002	0.0429	0.0799	0.1918	0.3297	0.4739	0.7812	0.5951	4.9756	0.9601	0.9601
2003	0.1134	0.1307	0.3180	0.5227	0.5930	0.6297	0.4187	0.5254	0.8022	0.8022
2004	0.1794	0.1890	0.3239	0.4267	0.6665	0.7737	0.8951	0.6026	1.1324	1.1324
2005	0.1228	0.1818	0.3533	0.5062	0.5739	0.7238	0.7391	0.9779	0.9779	0.9779

Table 4.7.4.1. BW. Description of some of the ICA runs performed at the WG in 2006.

Table 4.7.4.1. Description of some of the ICA runs performed at the WG in 2006. Mean values of SSB and F are presented for comparison.

Run	Separable Period	Ages Removed	Down weighting	No of fleets	Reference Age	Exploitatio n pattern	Age 1 Weight	F	Mean F	SSB	SSB Mean
1 Spaly	8	No	Manual	1	3	1 period	0.5	0.43	0.33	5.3	3.0
3	8	No	Manual	2	3	1 period	0.5	0.44	0.33	5.1	3.0
4	4	No	Manual	1	3	1 period	0.5	0.37	0.29	6.5	3.5
6	8	No	Iterative	1	3	1 period	1	0.43	0.34	5.2	3.0
7*	8	Yes	Manual	2	3	1 period	0.5	0.32	0.32	6.8	3.2
8	8	Yes	Manual	3	3	1 period	0.5	0.34	0.32	6.5	3.2
9	8	Yes	Manual	1	3	1 period	0.5	0.36	0.32	6.2	3.1
Final Run 2005	8	No	Manual	1	3	1 period	0.5	0.5	0.3	5.8	2.9

* Run 7 Final Run 2006

Table 4.7.4.2. Blue Whiting. Summary table for the final ICA run in 2006.

Year	Recruits, age 1 (‘000s)	Total Biomass (t)	SSB (t)	Landings (t)	Yield/SSB ratio	Mean F Ages 3-7	SOP %
1981	3614670	5216272	4197173	907732	0.2163	0.2136	98
1982	4561610	3776505	2983385	513203	0.172	0.1692	93
1983	16811360	3240080	2022037	561332	0.2776	0.1979	101
1984	19660340	3162108	1685616	626592	0.3717	0.2501	101
1985	11078430	3371898	1942123	676812	0.3485	0.3132	99
1986	9682400	3577730	2254833	801786	0.3556	0.4626	94
1987	9296000	3209656	1917943	656588	0.3423	0.3808	100
1988	7721450	2766112	1635248	552020	0.3376	0.4653	99
1989	9898650	2839950	1587146	598147	0.3769	0.475	94
1990	21894420	3144049	1566075	558788	0.3568	0.4015	100
1991	9429280	3798593	2051110	363724	0.1773	0.2016	99
1992	6486640	3993300	2658599	473789	0.1782	0.1501	99
1993	5886000	3710348	2542144	475143	0.1869	0.1734	99
1994	6934830	3593193	2476177	458028	0.185	0.1755	100
1995	8670280	3457211	2215170	505938	0.2284	0.2268	100
1996	22295230	3632951	2072247	629286	0.3037	0.2801	101
1997	40777780	5073373	2227404	640089	0.2874	0.2606	100
1998	31360260	6260408	2883554	1123732	0.3897	0.4433	99
1999	24129900	7046397	3619245	1251463	0.3458	0.3516	99
2000	47007220	8272615	3909096	1409143	0.3605	0.4454	99
2001	75120940	*****	4521358	1775305	0.3926	0.4579	100
2002	50893400	*****	5797550	1556955	0.2686	0.4462	100
2003	57618520	*****	7034001	2321407	0.33	0.3629	98
2004	40820400	*****	6935963	2377568	0.3428	0.4071	99
2005	50225670	*****	6783310	1996530	0.2943	0.3207	99

Table 4.7.4.3. Blue Whiting. Predicted catch as estimated in ICA final run in 2006

AGE	1998	1999	2000	2001	2002	2003	2004	2005
1	1513.1	928.5	2278.5	3740.8	2471.3	2287	1812.6	1765.9
2	2788.2	1726.1	1684	3329.4	5183.4	2886.9	3685.8	2065.5
3	2762	4298.2	4178.4	3259	6119	8163.5	6250.3	5721
4	1122.7	2063	5069.3	3849.5	2848.5	4657.5	8642.3	4763.6
5	595.2	489.8	1448.5	2724.4	1957.6	1265.4	2929	3878.2
6	402.9	280.4	369.9	836	1488.5	938.6	857.6	1422.5
7	274.2	157.4	177.2	177.4	379.1	592	531.5	346.2
8	232.6	123.4	113.8	97.4	92.3	173.6	384.1	247.2
9	212.5	74.8	64.8	45.2	36.5	30.2	81.4	127.5

Table 4.7.4.4. Blue Whiting. Fishing mortalities per year, as estimated in ICA final run in 2006

AGE	1981	1982	1983	1984	1985	1986	1987	1988	1989	1990	1991	1992	1993
1	0.0819	0.0364	0.1618	0.1373	0.1389	0.0769	0.1046	0.0626	0.1012	0.0845	0.0317	0.0718	0.0505
2	0.098	0.1173	0.1902	0.2469	0.1747	0.1208	0.0907	0.1231	0.1428	0.1117	0.071	0.1012	0.0705
3	0.1543	0.1253	0.1621	0.2296	0.333	0.2384	0.1507	0.1314	0.3512	0.1928	0.1115	0.1553	0.1319
4	0.1065	0.179	0.1543	0.2316	0.2356	0.5572	0.4066	0.206	0.2492	0.3409	0.1241	0.1737	0.2183
5	0.2658	0.1149	0.1401	0.2266	0.2614	0.5426	0.4871	0.5446	0.4174	0.2577	0.2739	0.1236	0.1832
6	0.2914	0.2076	0.1875	0.3183	0.4288	0.4492	0.3676	1.0403	0.6531	0.5712	0.1964	0.1785	0.1524
7	0.2499	0.2192	0.3458	0.2445	0.3071	0.5256	0.4921	0.4043	0.7042	0.6451	0.302	0.1196	0.1813
8	0.3006	0.2263	0.387	0.4139	0.2544	0.4119	0.724	0.4974	0.4494	1.1883	0.2037	0.243	0.0963
9	0.2403	0.2134	0.2961	0.3723	0.3595	0.435	0.3915	0.4307	0.4644	0.4685	0.2029	0.1968	0.1755
10	0.2403	0.2134	0.2961	0.3723	0.3595	0.435	0.3915	0.4307	0.4644	0.4685	0.2029	0.1968	0.1755

AGE	1994	1995	1996	1997	1998	1999	2000	2001	2002	2003	2004	2005
1	0.05	0.0384	0.0982	0.0593	0.0547	0.0434	0.0549	0.0565	0.055	0.0447	0.0502	0.0395
2	0.0263	0.075	0.0901	0.1066	0.1027	0.0815	0.1032	0.1061	0.1034	0.0841	0.0943	0.0743
3	0.1137	0.1358	0.1858	0.2162	0.2864	0.2272	0.2878	0.2959	0.2883	0.2345	0.2631	0.2072
4	0.1142	0.2054	0.2562	0.2582	0.4537	0.3599	0.4558	0.4686	0.4567	0.3715	0.4166	0.3282
5	0.2635	0.2657	0.215	0.2187	0.4611	0.3658	0.4633	0.4763	0.4642	0.3776	0.4235	0.3336
6	0.1837	0.2758	0.3563	0.2585	0.5189	0.4116	0.5214	0.5361	0.5224	0.4249	0.4766	0.3754
7	0.2022	0.2513	0.387	0.3516	0.4962	0.3936	0.4985	0.5125	0.4994	0.4062	0.4556	0.359
8	0.2294	0.2885	0.3838	0.4367	0.55	0.4362	0.5526	0.5681	0.5536	0.4503	0.505	0.3979
9	0.163	0.233	0.2898	0.2969	0.4297	0.3408	0.4317	0.4438	0.4325	0.3518	0.3946	0.3108
10	0.163	0.233	0.2898	0.2969	0.4297	0.3408	0.4317	0.4438	0.4325	0.3518	0.3946	0.3108

Table 4.7.4.5. Blue whiting. Population abundance by age from 1981 to 2006.

AGE	1981	1982	1983	1984	1985	1986	1987	1988	1989
1	3615	4562	16811	19660	11078	9682	9296	7721	9899
2	4107	2727	3601	11707	14032	7894	7341	6855	5938
3	5241	3048	1985	2438	7488	9647	5728	5489	4963
4	3641	3678	2202	1382	1586	4394	6223	4033	3940
5	2579	2679	2517	1545	898	1026	2061	3393	2687
6	2428	1619	1956	1792	1008	566	488	1037	1611
7	2315	1486	1077	1327	1067	538	296	277	300
8	2681	1476	977	624	851	643	260	148	151
9	2973	1625	964	543	338	540	349	103	74
10	7510	3851	1431	899	941	1236	660	157	112

AGE	1990	1991	1992	1993	1994	1995	1996	1997	1998
1	21894	9429	6487	5886	6935	8670	22295	40778	31360
2	7324	16472	7479	4943	4582	5401	6831	16546	31462
3	4215	5363	12562	5534	3772	3654	4102	5111	12177
4	2860	2846	3927	8806	3971	2756	2611	2789	3371
5	2515	1665	2058	2703	5795	2900	1838	1655	1764
6	1449	1591	1037	1489	1842	3646	1820	1213	1089
7	687	670	1070	710	1047	1255	2265	1044	767
8	121	295	406	778	485	700	799	1260	601
9	79	30	197	261	578	316	430	446	666
10	278	57	72	119	224	221	360	723	268

AGE	1999	2000	2001	2002	2003	2004	2005	2006
1	24130	47007	75121	50893	57619	40820	50226	697
2	24310	18918	36430	58128	39438	45110	31785	39527
3	23245	18346	13970	26824	42917	29685	33608	24160
4	7486	15163	11264	8508	16461	27792	18682	22366
5	1753	4277	7870	5772	4412	9295	15001	11016
6	911	996	2203	4002	2971	2476	4983	8798
7	530	494	484	1055	1943	1590	1259	2803
8	382	293	246	237	524	1060	826	720
9	284	202	138	114	112	274	524	454
10	534	437	203	445	102	124	21	329

Table 4.7.5.1 Blue Whiting, SMS exploratory run. Diagnostic

unweighted objective function contributions:

	Catch	CPUE	S/R	Penalty	Sum
CV>25%	-153.0	-10.4	7.0	1.25e-003	-156.4
Unbounded CV	-169.9	-10.5	8.1	0.00e+000	-172.3

sqrt(catch variance) ~ CV:

```
-----
```

age	Var 1	Var 2
1	0.461	0.406
2	0.433	0.341
3	0.262	0.168
4	0.262	0.168
5	0.262	0.168
6	0.262	0.168
7	0.354	0.511
8	0.354	0.511
9	0.354	0.511
10	0.354	0.511

```
-----
```

Table 4.7.5.2 Blue Whiting, SMS run. Diagnostic

objective function (negative log likelihood): -180.293

objective function weight:

Catch	CPUE	S/R
1	1	0.01

unweighted objective function contributions (total):

Catch	CPUE	S/R	Penalty	Sum
-169.9	-10.5	8.1	0.0 0.00e+000	-172.3

unweighted objective function contributions (per observation):

Catch	CPUE	S/R	Stomachs
-0.68	-0.10	0.32	0.00

contribution by fleet:

Norwegian acou. 1991-2006	total:	-9.898	mean:	-0.110
Norw. Sea May 2000-2006	total:	-0.597	mean:	-0.046

F, Year effect:

1981:	1.000
1982:	0.809
1983:	0.935
1984:	1.220
1985:	1.355
1986:	1.755
1987:	1.324
1988:	1.310
1989:	1.753
1990:	1.683
1991:	0.840
1992:	0.751
1993:	1.000
1994:	0.881
1995:	1.183
1996:	1.591
1997:	1.570
1998:	2.170
1999:	1.860
2000:	2.290
2001:	1.990
2002:	1.827
2003:	2.108
2004:	2.391
2005:	2.190

F, age effect:

	1	2	3	4	5	6	7	8-10
1981-1992:	0.074	0.113	0.167	0.215	0.261	0.345	0.433	0.440
1993-2005:	0.036	0.055	0.137	0.208	0.224	0.257	0.258	0.286

sqrt(catch variance) ~ CV:

Age	
1	0.406
2	0.341
3-6	0.168
7-10	0.511

Survey catchability:

	age 1	age 2	age 3	age 4	age 5	age 6	age 7-8
Norwegian acou. 1991-2006			1.598	2.230	1.601	1.271	1.179
Norw. Sea May 2000-2006	1.078		0.644				

sqrt(Survey variance) ~ CV:

	age 1	age 2	age 3	age 4	age 5	age 6	age 7-8
Norwegian acou. 1991-2006			0.41	0.41	0.62	0.62	0.64
Norw. Sea May 2000-2006	0.59	0.57					

Table 4.7.5.3 Blue Whiting, SMS run. Estimated fishing mortality.

Age	1981	1982	1983	1984	1985	1986	1987	1988
1	0.0745	0.0602	0.0696	0.0908	0.1009	0.1307	0.0986	0.0975
2	0.1131	0.0915	0.1058	0.1380	0.1532	0.1985	0.1498	0.1482
3	0.1670	0.1351	0.1561	0.2038	0.2262	0.2931	0.2211	0.2187
4	0.2147	0.1737	0.2007	0.2620	0.2908	0.3768	0.2843	0.2812
5	0.2609	0.2110	0.2440	0.3184	0.3534	0.4579	0.3455	0.3417
6	0.3451	0.2791	0.3226	0.4211	0.4674	0.6056	0.4569	0.4519
7	0.4329	0.3501	0.4047	0.5282	0.5864	0.7597	0.5732	0.5669
8	0.4398	0.3557	0.4112	0.5366	0.5957	0.7718	0.5823	0.5759
9	0.4398	0.3557	0.4112	0.5366	0.5957	0.7718	0.5823	0.5759
10	0.4398	0.3557	0.4112	0.5366	0.5957	0.7718	0.5823	0.5759
Avg. F 3-7	0.284	0.230	0.266	0.347	0.385	0.499	0.376	0.372
Age	1989	1990	1991	1992	1993	1994	1995	1996
1	0.1305	0.1253	0.0625	0.0559	0.0358	0.0316	0.0424	0.0570
2	0.1983	0.1905	0.0950	0.0849	0.0552	0.0487	0.0653	0.0878
3	0.2927	0.2811	0.1402	0.1253	0.1369	0.1206	0.1619	0.2178
4	0.3763	0.3614	0.1802	0.1611	0.2084	0.1837	0.2465	0.3316
5	0.4573	0.4393	0.2191	0.1958	0.2236	0.1971	0.2645	0.3558
6	0.6049	0.5809	0.2897	0.2590	0.2572	0.2267	0.3043	0.4092
7	0.7588	0.7287	0.3634	0.3249	0.2580	0.2274	0.3052	0.4105
8	0.7708	0.7403	0.3692	0.3301	0.2859	0.2520	0.3382	0.4549
9	0.7708	0.7403	0.3692	0.3301	0.2859	0.2520	0.3382	0.4549
10	0.7708	0.7403	0.3692	0.3301	0.2859	0.2520	0.3382	0.4549
Avg. F 3-7	0.498	0.478	0.239	0.213	0.217	0.191	0.256	0.345
Age	1997	1998	1999	2000	2001	2002	2003	2004
1	0.0563	0.0778	0.0667	0.0821	0.0713	0.0655	0.0756	0.0857
2	0.0867	0.1198	0.1027	0.1264	0.1099	0.1009	0.1164	0.1320
3	0.2149	0.2970	0.2546	0.3134	0.2724	0.2501	0.2886	0.3272
4	0.3272	0.4521	0.3876	0.4772	0.4147	0.3808	0.4393	0.4982
5	0.3511	0.4851	0.4159	0.5120	0.4449	0.4085	0.4713	0.5345
6	0.4038	0.5580	0.4784	0.5889	0.5118	0.4699	0.5422	0.6148
7	0.4051	0.5598	0.4799	0.5908	0.5134	0.4714	0.5439	0.6167
8	0.4489	0.6202	0.5318	0.6546	0.5689	0.5224	0.6027	0.6834
9	0.4489	0.6202	0.5318	0.6546	0.5689	0.5224	0.6027	0.6834
10	0.4489	0.6202	0.5318	0.6546	0.5689	0.5224	0.6027	0.6834
Avg. F 3-7	0.340	0.470	0.403	0.496	0.431	0.396	0.457	0.518
Age	2005							
1	0.0785							
2	0.1209							
3	0.2997							
4	0.4564							
5	0.4896							
6	0.5632							
7	0.5650							
8	0.6260							
9	0.6260							
10	0.6260							
Avg. F 3-7	0.475							

Table 4.7.5.4 Blue Whiting, SMS run. Estimated stock numbers.

Age	1981	1982	1983	1984	1985	1986	1987	1988
1	3307001	4165174	15350509	18855076	10787485	8649177	9019770	6776130
2	3793105	2513276	3210860	11722804	14096611	7984770	6213990	6691443
3	4532932	2773327	1877763	2364955	8360253	9901509	5360143	4379752
4	2427182	3140434	1983714	1315128	1579297	5459034	6047248	3517836
5	2307870	1603241	2161295	1328738	828579	966724	3066345	3725877
6	2145142	1455571	1062886	1386454	791245	476411	500702	1777093
7	1832810	1243741	901490	630241	745044	405932	212872	259581
8	1760769	973324	717488	492410	304266	339368	155478	98247
9	1489618	928653	558374	389391	235736	137307	128423	71107
10	3103712	2422584	1922527	1346421	831003	481391	234126	165809
TSB	3411356	2819308	2832302	2938048	3174085	3287009	2991379	2675794
SSB	2934624	2387669	1941540	1708205	1992076	2317482	2032276	1847167
Age	1989	1990	1991	1992	1993	1994	1995	1996
1	9481372	24343811	8364120	5461825	5185755	5653690	8233816	23351823
2	5032405	6812960	17583094	6433030	4228737	4096258	4484906	6461402
3	4724026	3379047	4610641	13091430	4838158	3276244	3194451	3439772
4	2881390	2886178	2088499	3281044	9455675	3454435	2377514	2224389
5	2174205	1619220	1646237	1427892	2286500	6285399	2353697	1521232
6	2167521	1126726	854439	1082682	961144	1496979	4225644	1479175
7	925935	969216	516021	523609	684170	608466	977036	2552076
8	120560	354975	382889	293751	309777	432775	396847	589518
9	45220	45665	138618	216708	172893	190564	275408	231678
10	109046	58432	40650	101462	187266	221557	262264	313892
TSB	2691368	2983318	3523588	3588649	3350203	3165285	3132397	3382752
SSB	1767045	1575252	1990041	2612481	2517503	2404827	2228112	2086005
Age	1997	1998	1999	2000	2001	2002	2003	2004
1	44850292	29478471	24142508	40003049	65081694	46670179	41036186	26288523
2	18058988	34710832	22329200	18491361	30170917	49616161	35787978	31152478
3	4845266	13557768	25210805	16497431	13341540	22131812	36724317	26081557
4	2265076	3199779	8248111	16001234	9872581	8318601	14110292	22530781
5	1307213	1336966	1666877	4583019	8129212	5339134	4653929	7445362
6	872641	753402	673896	900391	2248755	4265426	2905277	2378287
7	804330	477087	353045	341956	409069	1103594	2182769	1383124
8	1385963	439184	223173	178878	155072	200432	563917	1037394
9	306259	724357	193384	107361	76102	71880	97331	252712
10	283428	308193	454659	311751	178307	117925	92170	84922
TSB	5028294	6328251	6993359	7694636	9509899	10857210	11379314	9525643
SSB	2219566	3258054	4041300	4281525	4710379	5803770	7037433	6466520
Age	2005							
1	29955346							
2	19755859							
3	22352088							
4	15394610							
5	11209033							
6	3571986							
7	1052919							
8	611161							
9	428838							
10	139571							
TSB	8048900							
SSB	5508420							

Table 4.7.5.5 Blue Whiting, SMS. Stock summary, 1981-2005. (SSB in 2006 does not include age 1)

Year	Recruits (1000)	SSB (tonnes)	TSB (tonnes)	SOP (tonnes)	mean-F age 3-7
1981	3307001	2934624	3411356	922980	0.284
1982	4165174	2387669	2819308	550643	0.230
1983	15350509	1941540	2832302	553344	0.266
1984	18855076	1708205	2938048	615569	0.347
1985	10787485	1992076	3174085	678214	0.385
1986	8649177	2317482	3287009	847145	0.499
1987	9019770	2032276	2991379	654718	0.376
1988	6776130	1847167	2675794	552264	0.372
1989	9481372	1767045	2691368	630316	0.498
1990	24343811	1575252	2983318	558128	0.478
1991	8364120	1990041	3523588	364008	0.239
1992	5461825	2612481	3588649	474592	0.213
1993	5185755	2517503	3350203	475198	0.217
1994	5653690	2404827	3165285	457696	0.191
1995	8233816	2228112	3132397	505176	0.256
1996	23351823	2086005	3382752	621104	0.345
1997	44850292	2219566	5028294	639681	0.340
1998	29478471	3258054	6328251	1131955	0.470
1999	24142508	4041300	6993359	1261033	0.403
2000	40003049	4281525	7694636	1412449	0.496
2001	65081694	4710379	9509899	1771805	0.431
2002	46670179	5803770	10857210	1556955	0.396
2003	41036186	7037433	11379314	2365319	0.457
2004	26288523	6466520	9525643	2400795	0.518
2005	29955346	5508420	8048900	2132298	0.475
2006		4751276			

assuming a recruitment of 11.4 billion in 2006 SSB in 2006 will be 4800181 t

Table 4.7.6.1 . Blue whiting. XSA exploratory tuning results.

Number of surveys used	q independied of age after ages	Total SSQ in log catch residuals	Number of years with yearly effect in residuals	Regression type
3	7	194	10	C
4	7	189	7	C
4	5	158	9	C
4	5	145	7	P
4	7	143	7	P
4	6	141	7	P

Table 4.7.6.2 . Blue whiting. XSA exploratory tuning results.

	Recruits	TOTALBIO	SSB	Yield/SSB	F _{bar} 3-7
	(1000)	(tonnes)	(tonnes)		
1981	3606503	5481217	4553926	0.20	0.20
1982	4515455	4031962	3262638	0.16	0.16
1983	16948910	3352633	2050743	0.26	0.20
1984	19894196	3201943	1455250	0.42	0.26
1985	11067088	3373549	1498075	0.45	0.32
1986	8717677	3461705	1823209	0.46	0.47
1987	9121735	3085313	1587699	0.41	0.39
1988	7354414	2666014	1361681	0.40	0.48
1989	9644591	2718879	1295058	0.48	0.48
1990	21824190	3005400	1195198	0.46	0.42
1991	9341070	3653768	1345988	0.27	0.22
1992	6491843	3852115	1875301	0.25	0.16
1993	6142102	3597552	2169257	0.21	0.18
1994	6808804	3464398	2163843	0.21	0.18
1995	8863270	3410336	1942424	0.26	0.23
1996	25336820	3707399	1774203	0.35	0.28
1997	43095512	5331546	1643427	0.38	0.26
1998	29897654	6517584	2003048	0.56	0.39
1999	24881848	7153834	2521883	0.50	0.34
2000	41852364	7814304	2862209	0.49	0.49
2001	69648104	10056436	3091003	0.57	0.44
2002	48659600	11353141	3607433	0.43	0.46
2003	37283232	11864384	4643270	0.50	0.42
2004	18057242	9424173	4964402	0.48	0.50
2005	20379396	7440851	4368735	0.46	0.47

Table 4.7.8.1 Tuning data for the blue whiting assessment. Inside the framed areas constant selection pattern is assumed. -1=missing data.

Year	Month	Min. obs. num	3	4	5	6	7	8
Norwegian acoustic spawning stock survey, ages 2-8								
1991	3	1	6340	8497	7407	4558	2019	545
1992	3	1	26123	4719	1574	1386	810	616
1993	3	1	3321	26771	2643	1270	557	426
1994	3	1	2950	4476	11354	1742	1687	908
1995	3	1	9874	7906	6861	9467	1795	1083
1996	3	1	7433	8371	2399	4455	4111	1202
1997	3	1	-1	-1	-1	-1	-1	-1
1998	3	1	34991	4697	1674	279	407	381
1999	3	1	60309	26103	1481	316	72	153
2000	3	1	31011	41382	6843	898	427	228
2001	3	1	12843	13805	8292	718	175	51
2002	3	1	54740	12757	5266	8404	1450	305
2003	3	1	70303	28756	5735	2430	1708	260
2004	3	1	40669	50137	15649	4454	2218	1313
2005	3	1	19968	30459	31708	7455	1993	747
2006	3	1	19446	36617	15998	8167	1592	466

Norwegian Sea ecosystem survey, ages 1-2

Year	Month	Min. obs. num	1	2
2000	5	1	48927	3133
2001	5	1	85772	25110
2002	5	1	15251	46656
2003	5	1	35688	21487
2004	5	1	49254	22086
2005	5	1	54660	19904
2006	5	1	570*	18300

*=used only in exploratory runs

Table 4.9.1.1 Blue Whiting. Input to short term projection.

Age	Weight in the stock (kg)	Weight in the catch (kg)	Proportion mature	Natural mortality (yr ⁻¹)	F status quo (yr ⁻¹)	Stock numbers 2006 (thousands)
1	0.039	0.039	0.11	0.2	0.078	11400000
2	0.068	0.068	0.40	0.2	0.121	22673895
3	0.084	0.084	0.82	0.2	0.300	14332851
4	0.099	0.099	0.86	0.2	0.456	13560624
5	0.113	0.113	0.91	0.2	0.490	7985783
6	0.137	0.137	0.94	0.2	0.563	5624331
7	0.156	0.156	1.00	0.2	0.565	1665136
8	0.166	0.166	1.00	0.2	0.626	489969
9	0.195	0.195	1.00	0.2	0.626	267555
10+	0.217	0.217	1.00	0.2	0.626	248839

Recruitment in 2007: Geometric mean 1995-2004: 30900 millions.

Table 4.9.1.2 Blue Whiting. Short term projection results.

2006						2008	
Biomass	SSB	FMult	FBar	Landings	Biomass	SSB	
6653080	4800181	1.2665	0.6122	2110000			
2007						2008	
Biomass	SSB	FMult	FBar	Landings	Biomass	SSB	
5607856	3749208		0	0	0	7139357	
.	.		0.1	0.05	166725	6960568	
.	.		0.2	0.10	326513	6789268	
.	.		0.3	0.15	479688	6625102	
.	.		0.4	0.19	626562	6467732	
.	.		0.5	0.24	767429	6316838	
.	.		0.6	0.29	902568	6172114	
.	.		0.662	0.32	983596	6085357	
.	.		0.7	0.34	1032247	6033272	
.	.		0.8	0.39	1156719	5900036	
.	.		0.9	0.44	1276223	5772145	
.	.		1.0	0.48	1390988	5649351	
.	.		1.055	0.51	1494281	5649080	
.	.		1.1	0.53	1501233	5531417	
.	.		1.2	0.58	1607164	5418120	
.	.		1.3	0.63	1708978	5309244	
.	.		1.4	0.68	1806861	5204589	
.	.		1.5	0.73	1900992	5103960	
.	.		1.6	0.77	1991540	5007174	
.	.		1.7	0.82	2078667	4914056	
.	.		1.8	0.87	2162525	4824441	
.	.		1.9	0.92	2243260	4738171	
.	.		2.0	0.97	2321013	4655094	

Input units are thousands and kg - output in tonnes

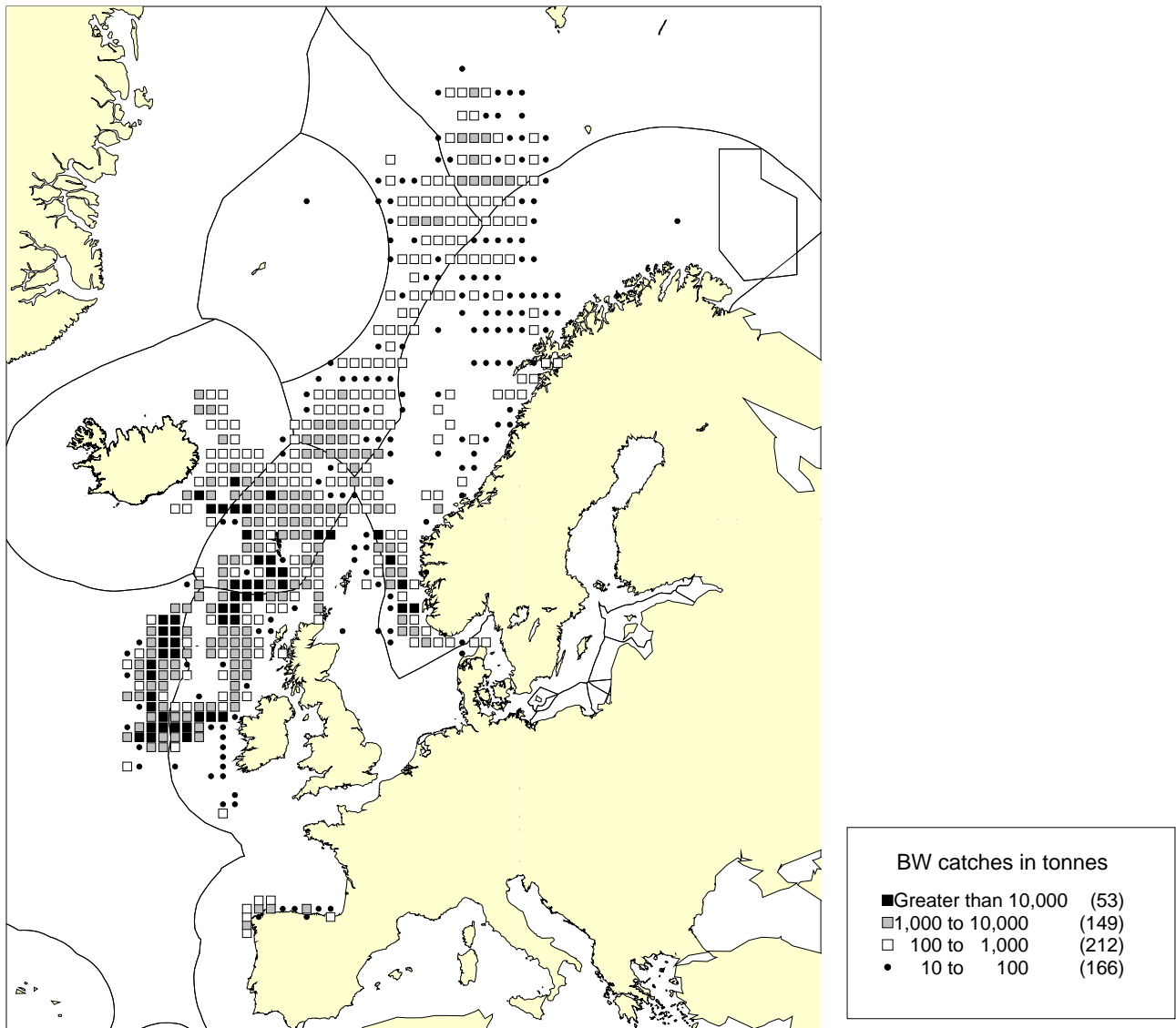
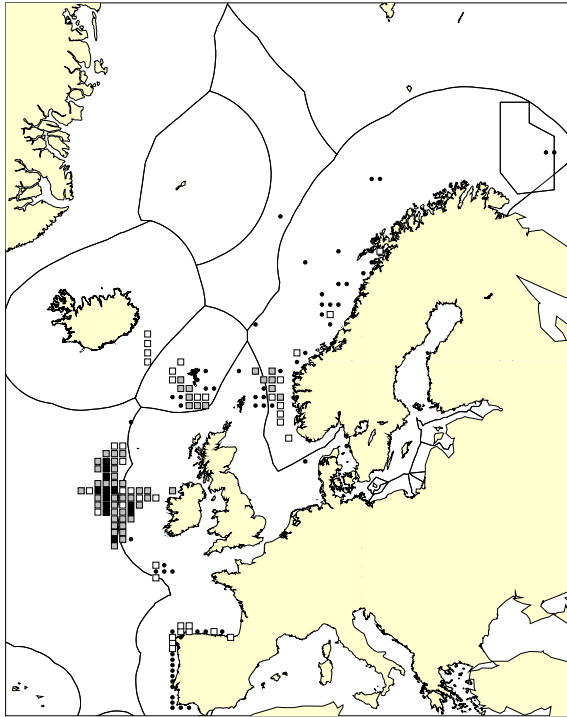
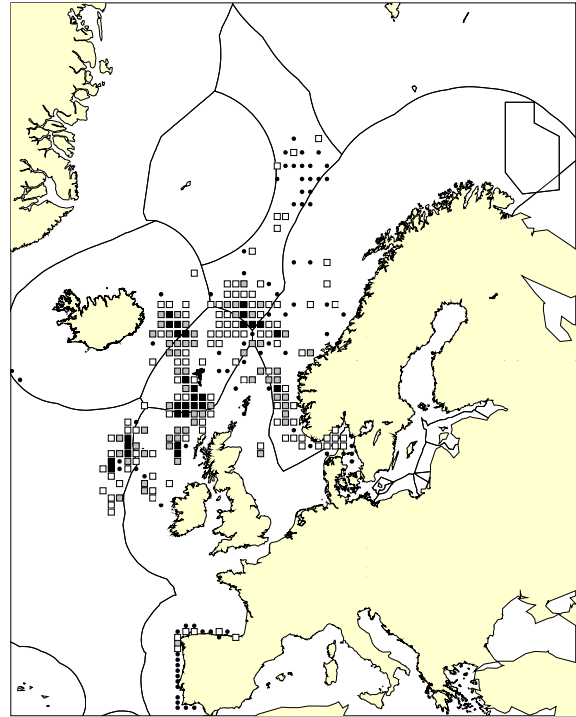

Figure 4.3.1. Total catches of blue whiting in 2005 by ICES rectangle. Grading of the symbols: small dots 10-100 t, white squares 100-1 000 t, grey squares 1 000-10 000 t, and black squares > 10 000 t. Catches below 10 t are not shown on the map.



Quarter 1



Quarter 2

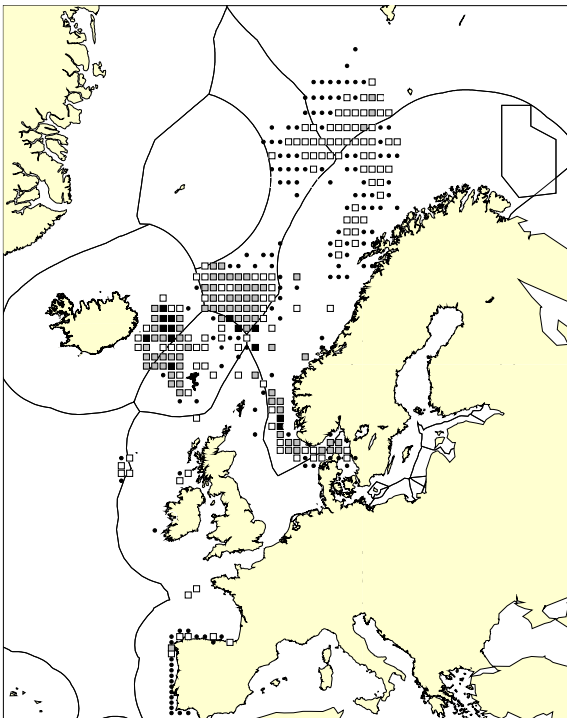

Quarter 3

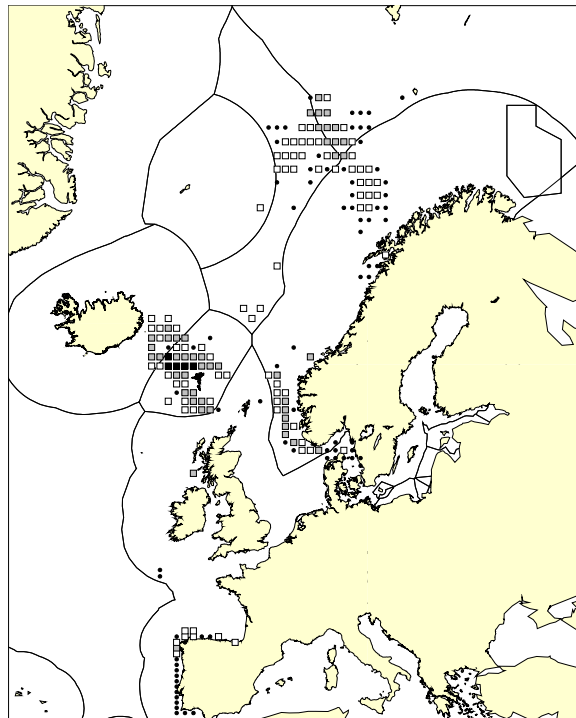

Quarter 4

Figure 4.3.2. Total catches of blue whiting in 2005 by quarter and ICES rectangle. Grading of the symbols: small dots 10-100 t, white squares 100-1 000 t, grey squares 1 000-10 000 t, and black squares > 10 000 t.

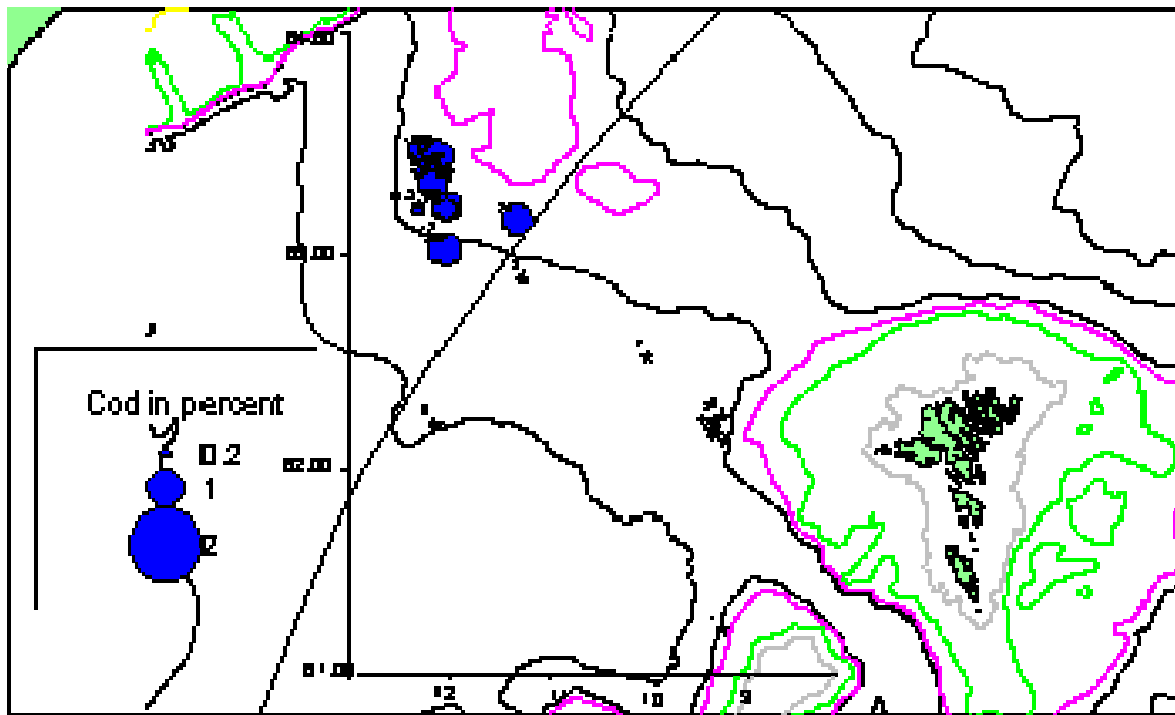

Cod

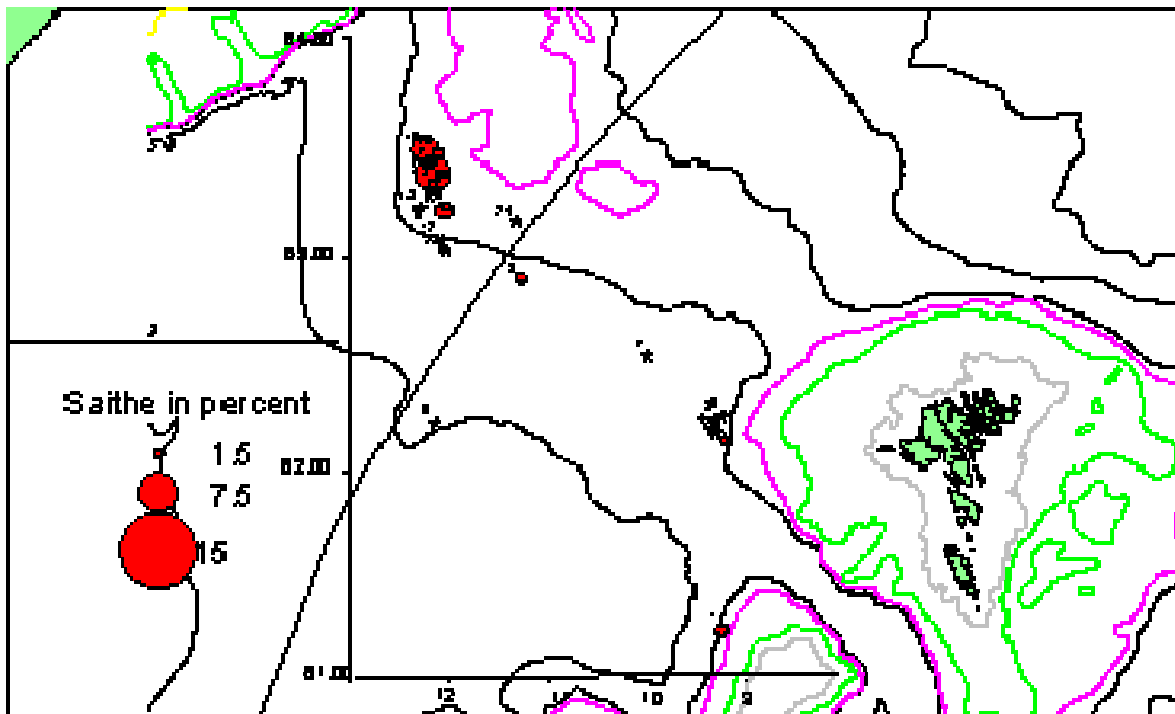

Saithe

Figure 4.4.2.1. Faroese screenings on board the factory trawler M/T Næraberg in May and June 2005, cod above and saithe lower panel (Lamhaug, Faroese Fisheries Laboratory).

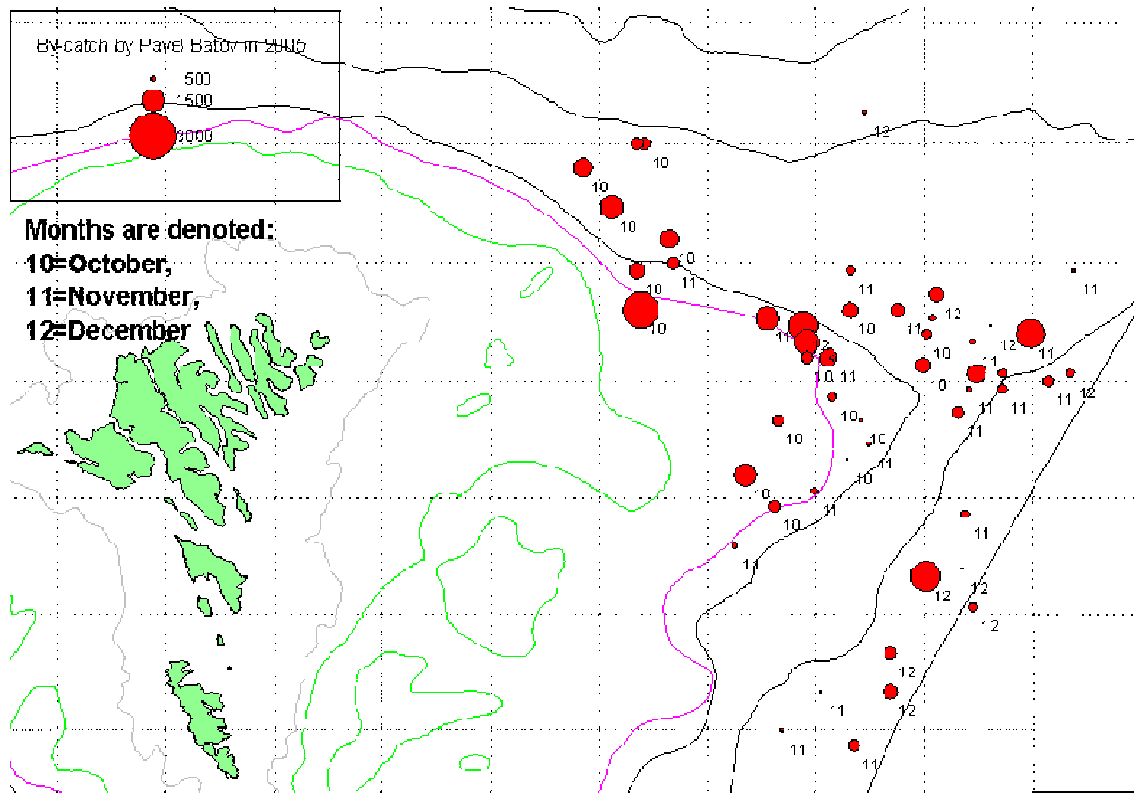

Figure 4.4.2.2. Russian by-catch of saithe in Faroese waters in late 2005 (Data from Faroese Coastguard).

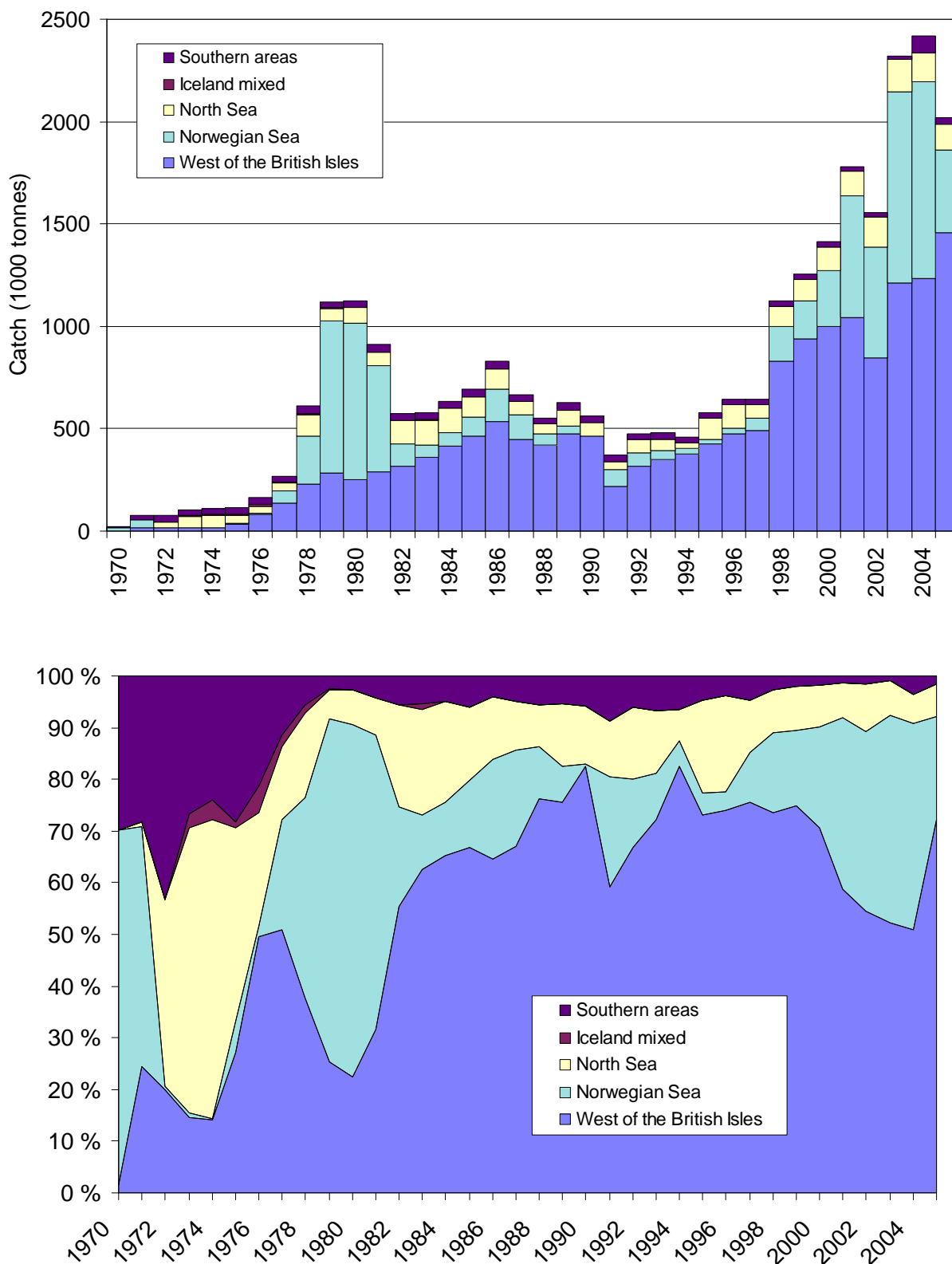

Figure 4.5.2.1. Development of blue whiting fisheries in different sub-areas in terms of absolute (top) and relative catches (bottom).

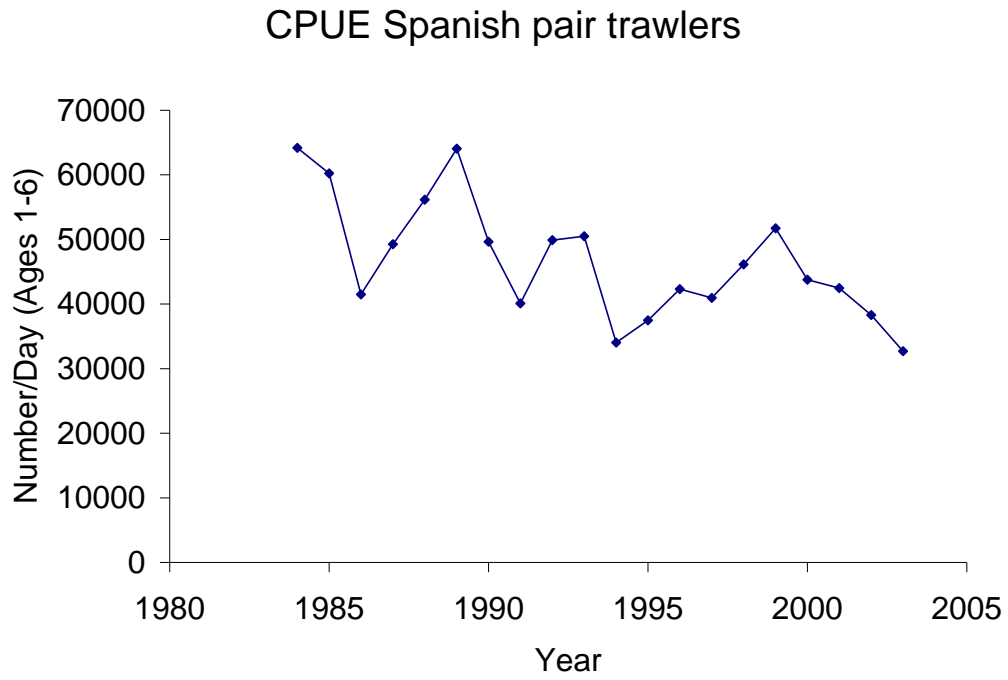

Figure 4.5.9.1.1. Blue whiting CPUE from Spanish Pair trawlers in ICES Div VIIIc and IXa (North).

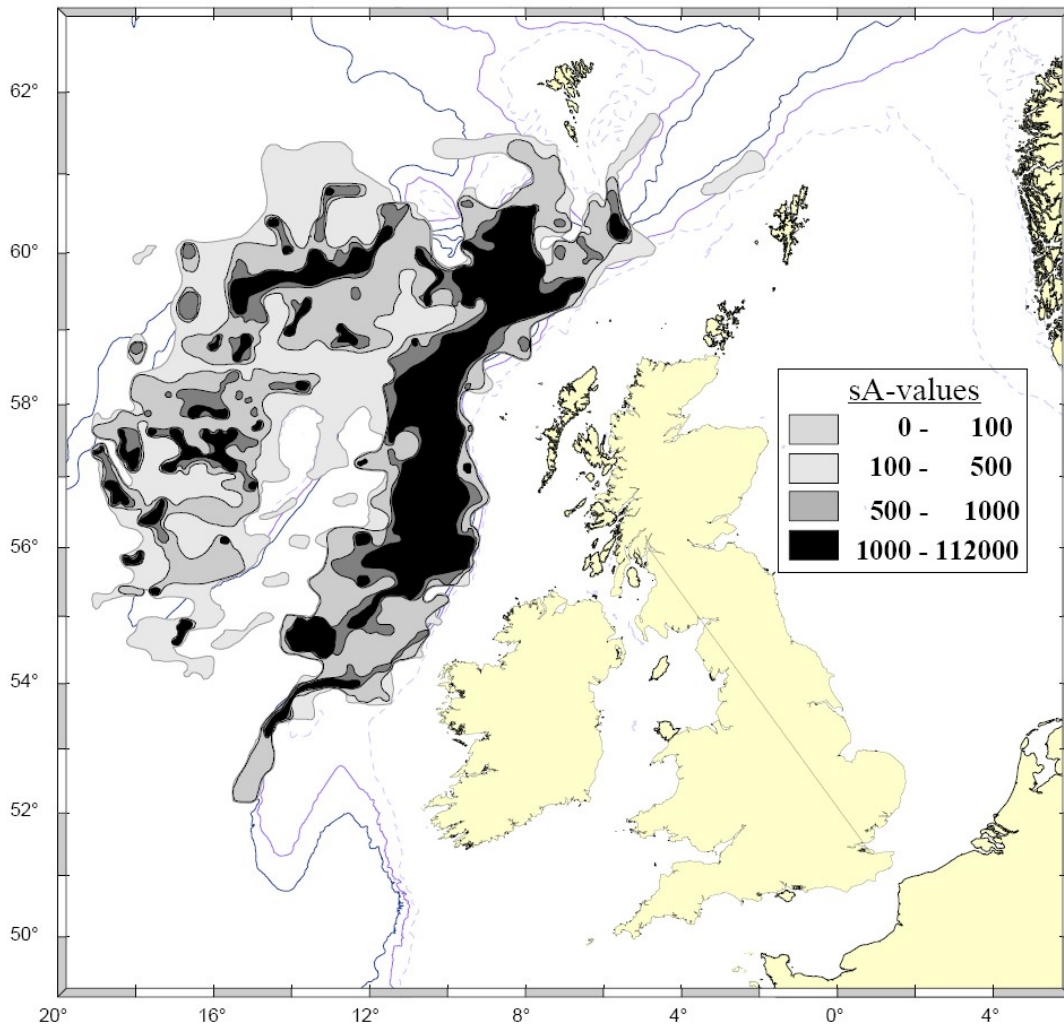

Figure 4.6.1.1. Blue Whiting: Schematic map of blue whiting acoustic density ($s_A^2, m^2/nm^2$) in the international pring survey in 2006.

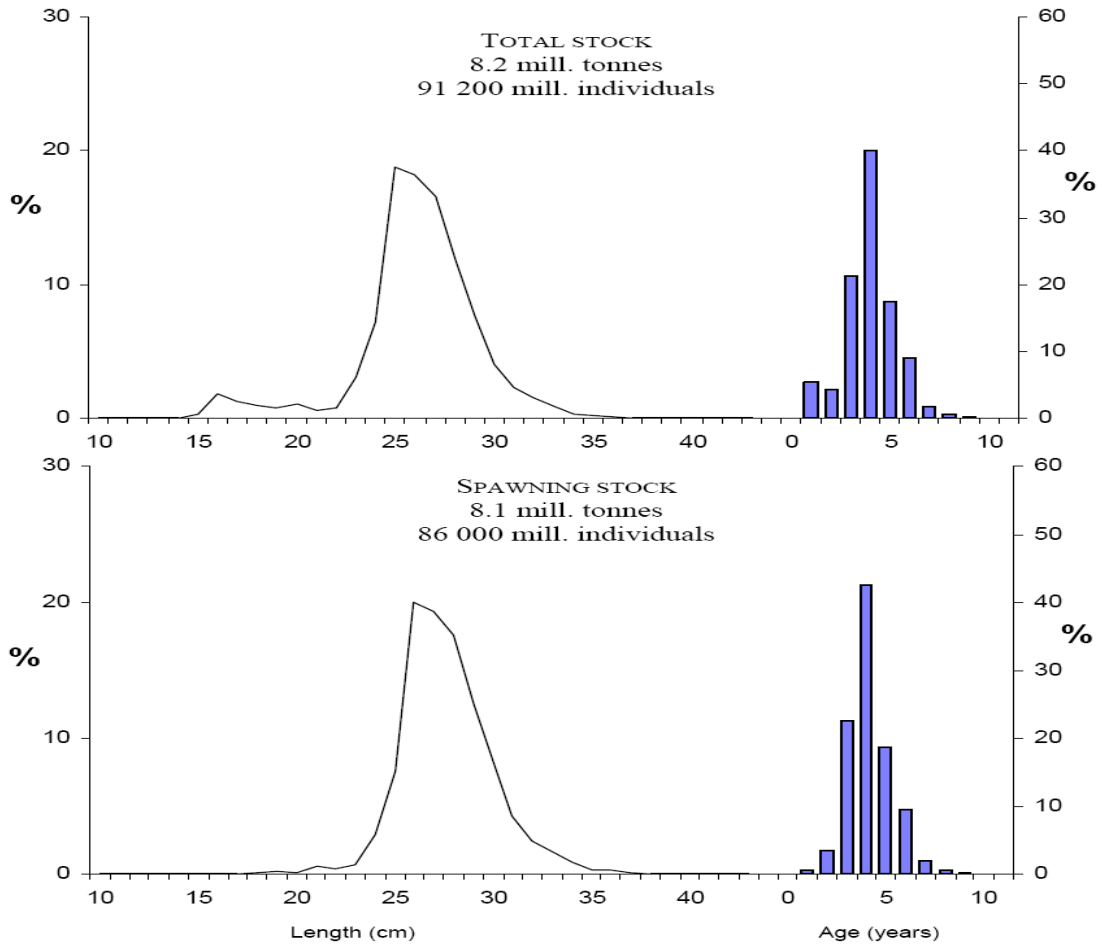

Figure 4.6.1.2. Length and age distribution of blue whiting estimated from the Norwegian blue whiting spawning stock survey with R/V "G. O. Sars" in March-April 2006.

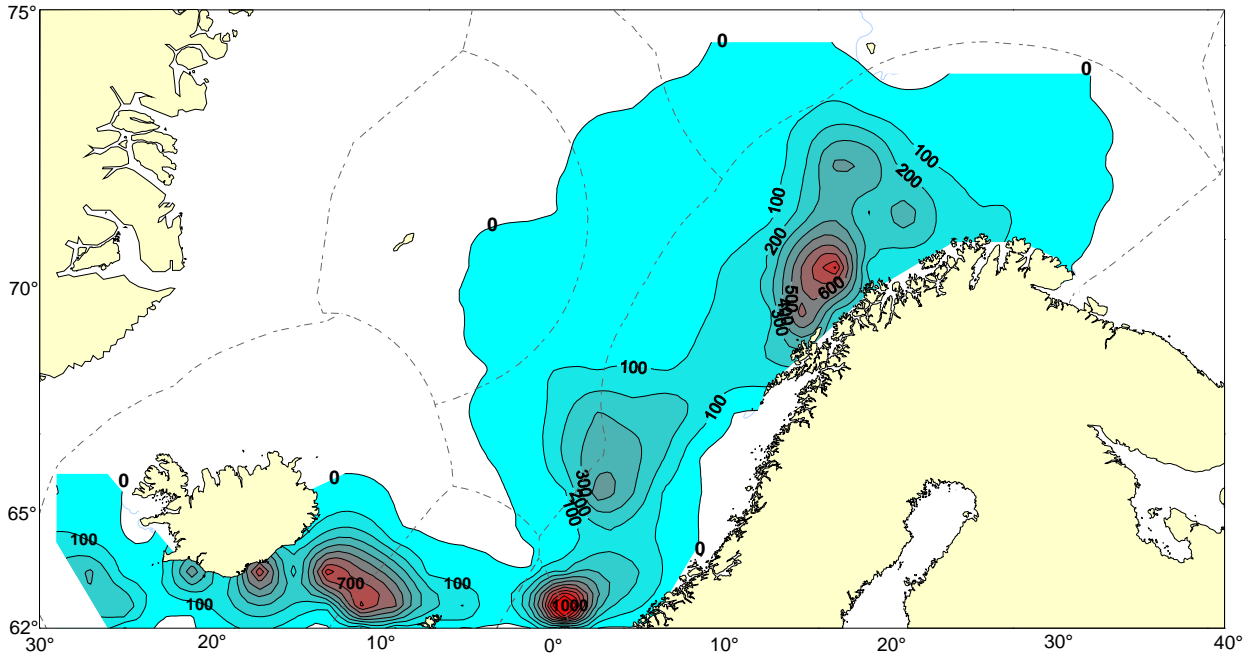
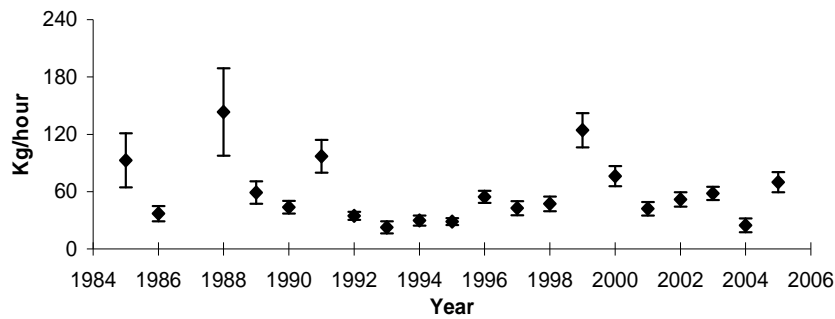

Figure 4.6.2.1. Acoustic density of blue whiting recorded in the North-east Atlantic Ecosystem Survey in May-June 2006. Density is terms of sA-values (m2/nm2) based on combined 5 nm values reported by each of the research vessels “Dana”, “Magnus Heinason”, “Arni Fridriksson”, “Johan Hjort” and “G. O. Sars”.

Spanish Bottom Trawl Survey



Spanish Bottom Trawl Survey

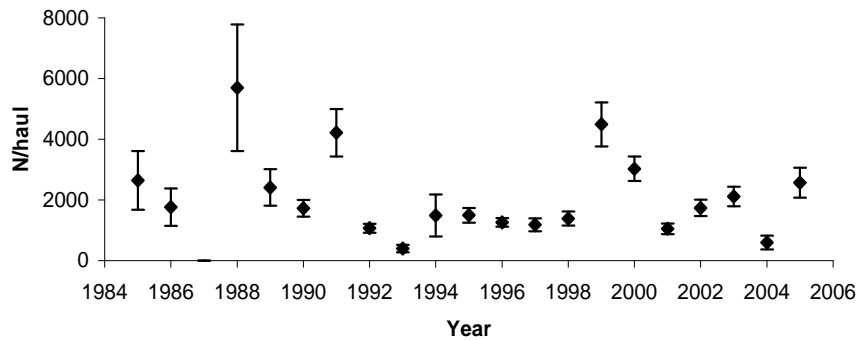

Figure 4.6.6.1 Blue whiting mean catch rates (Kg/haul and Number/haul) in Spanish bottom trawl survey.

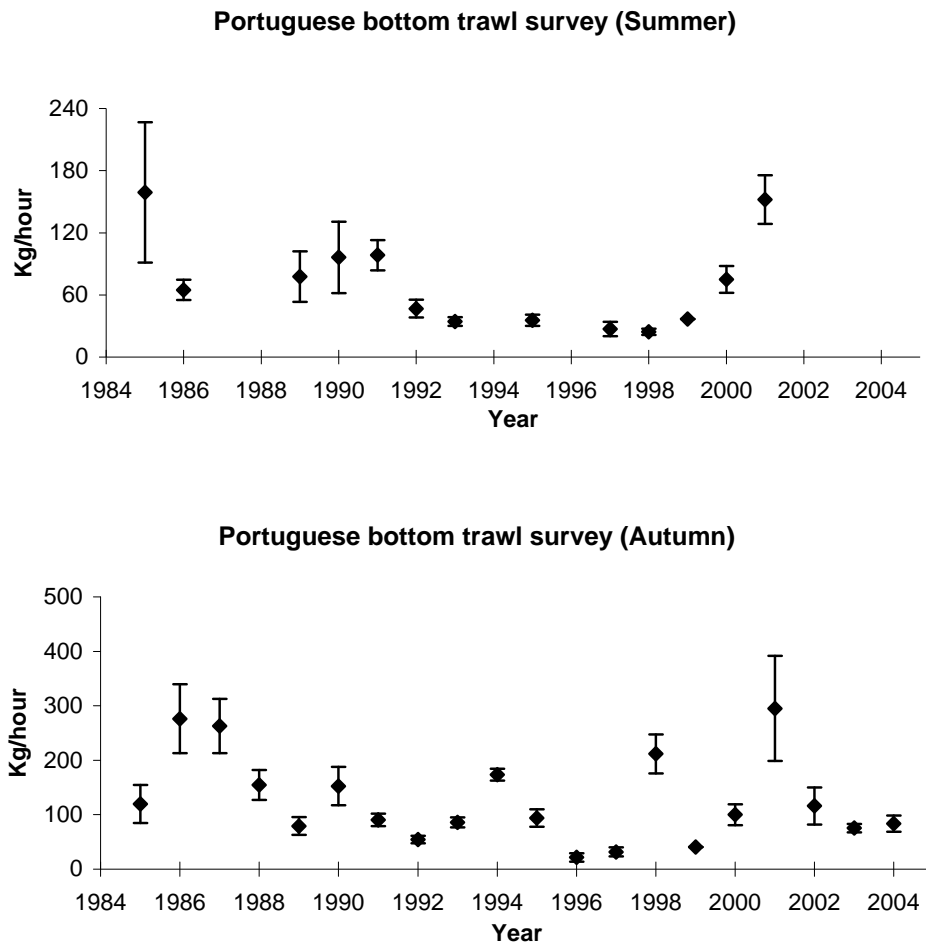

Figure 4.6.7.1 Blue whiting. Mean catch rates (Kg/haul and Number/haul) in Portuguese bottom trawl survey.

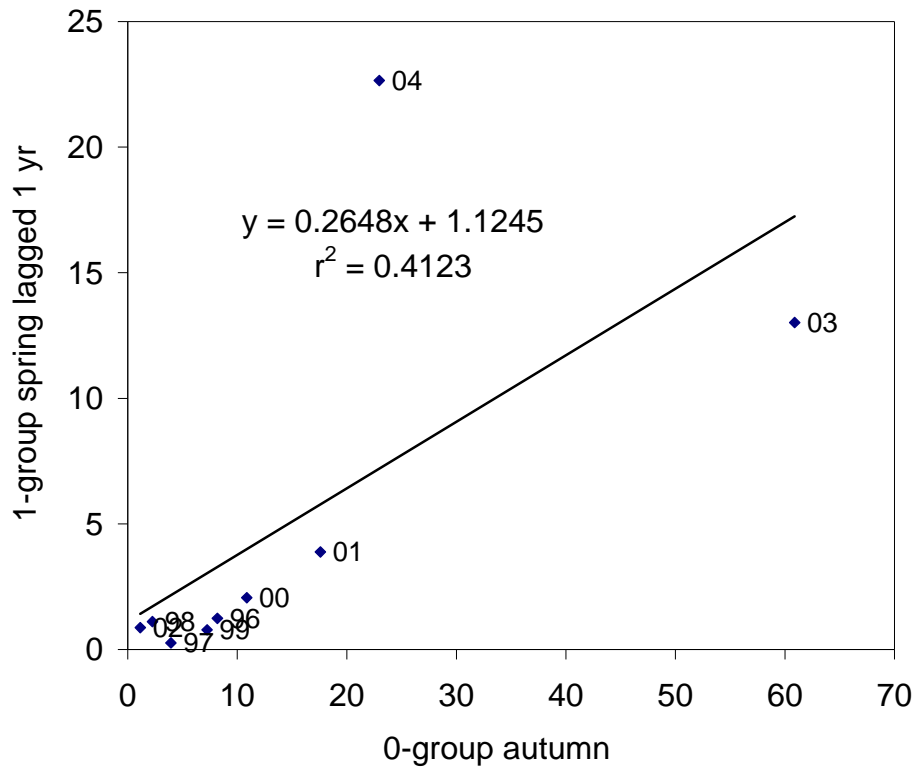

Figure 4.6.12.1 Bottom trawl 0-group index (number of blue whiting caught 10^{-3}) of Faroes plateau bottom trawl survey from autumn 1996-2004 compared to the following 1-group spring index lagged one year to match the 0-group index. Year is indicated on the points.

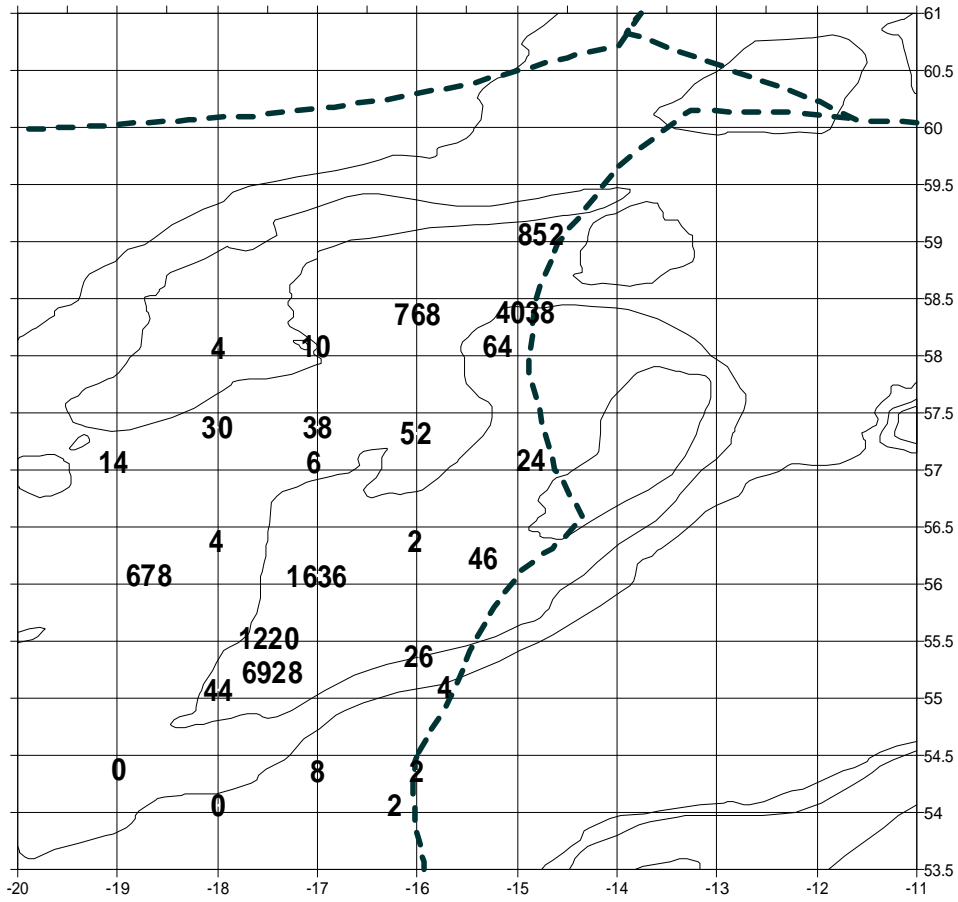

Figure 4.6.15.1. Number of blue whiting eggs per m² sampled from a depth of 600m observed by R/V ATLANTNIRO March 2006.

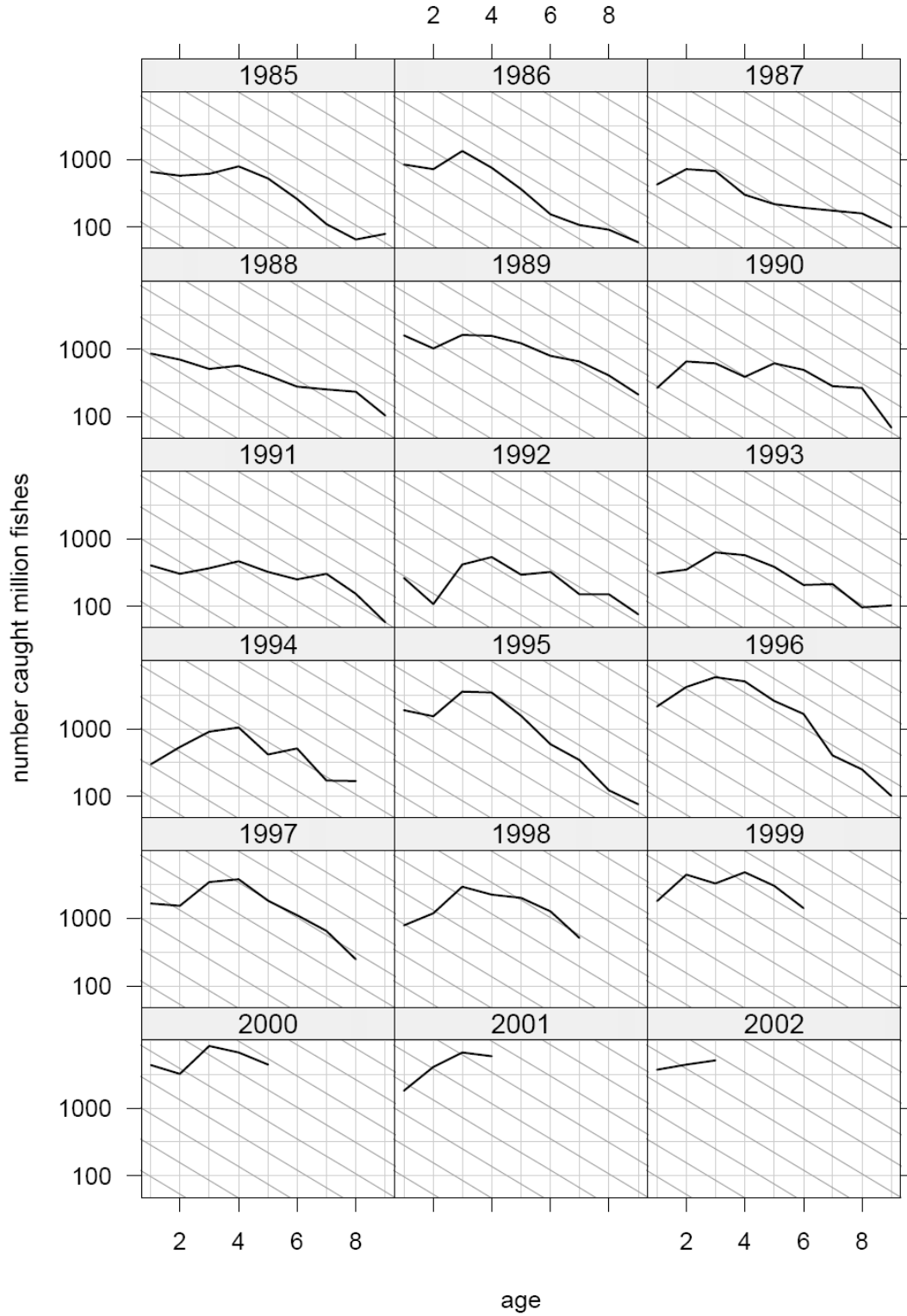

Figure 4.7.1.1 Age disaggregated catch in numbers of blue whiting plotted on log scale. The labels above each figure indicate yearclasses. The grey lines correspond to $Z=0.6$.

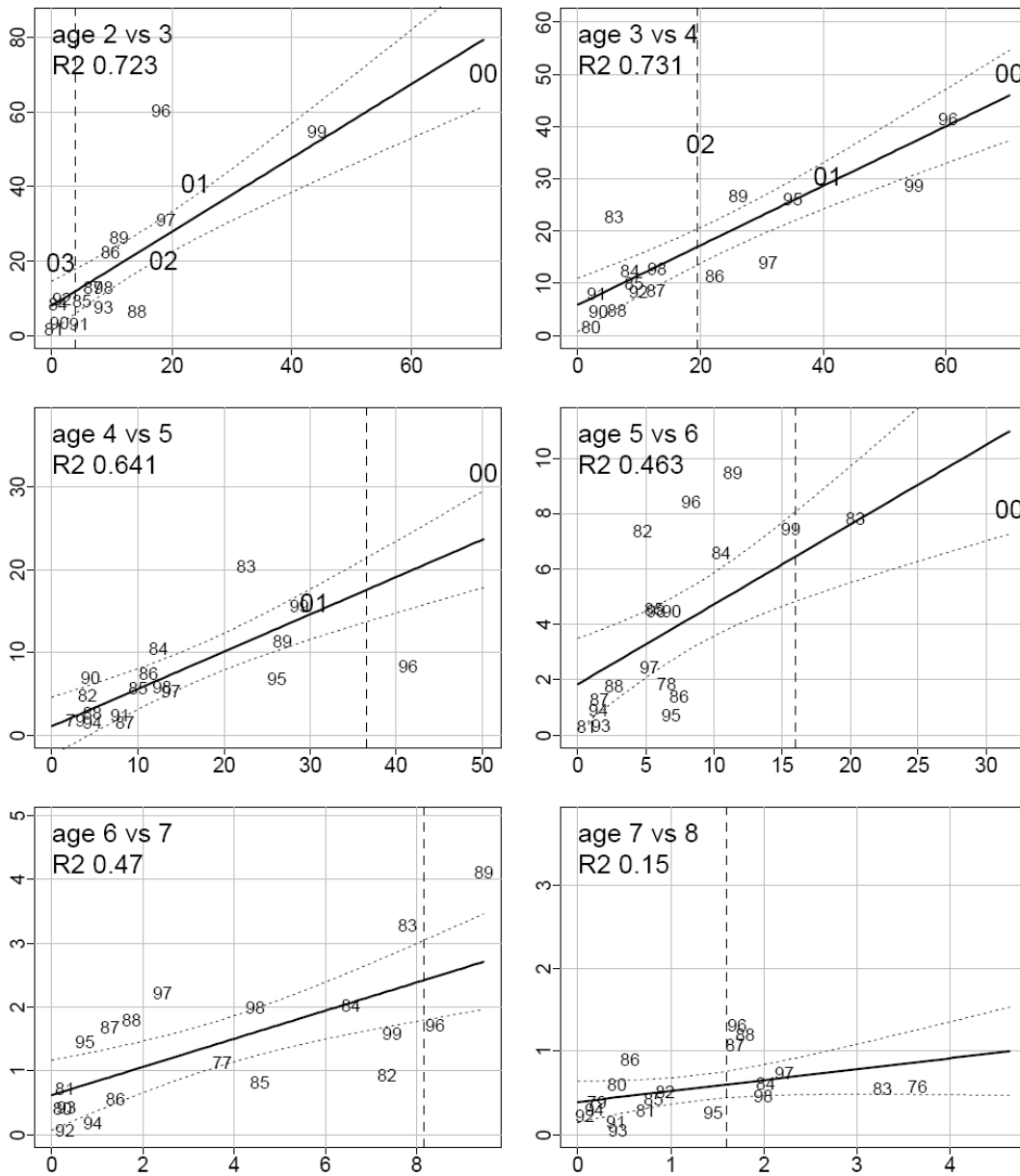

Figure 4.7.1.2. Abundance index of blue whiting in the spawning fish survey plotted against the abundance index of the same year class the following year. The dashed line shows the most recent estimate. The labels in the picture indicate year class.

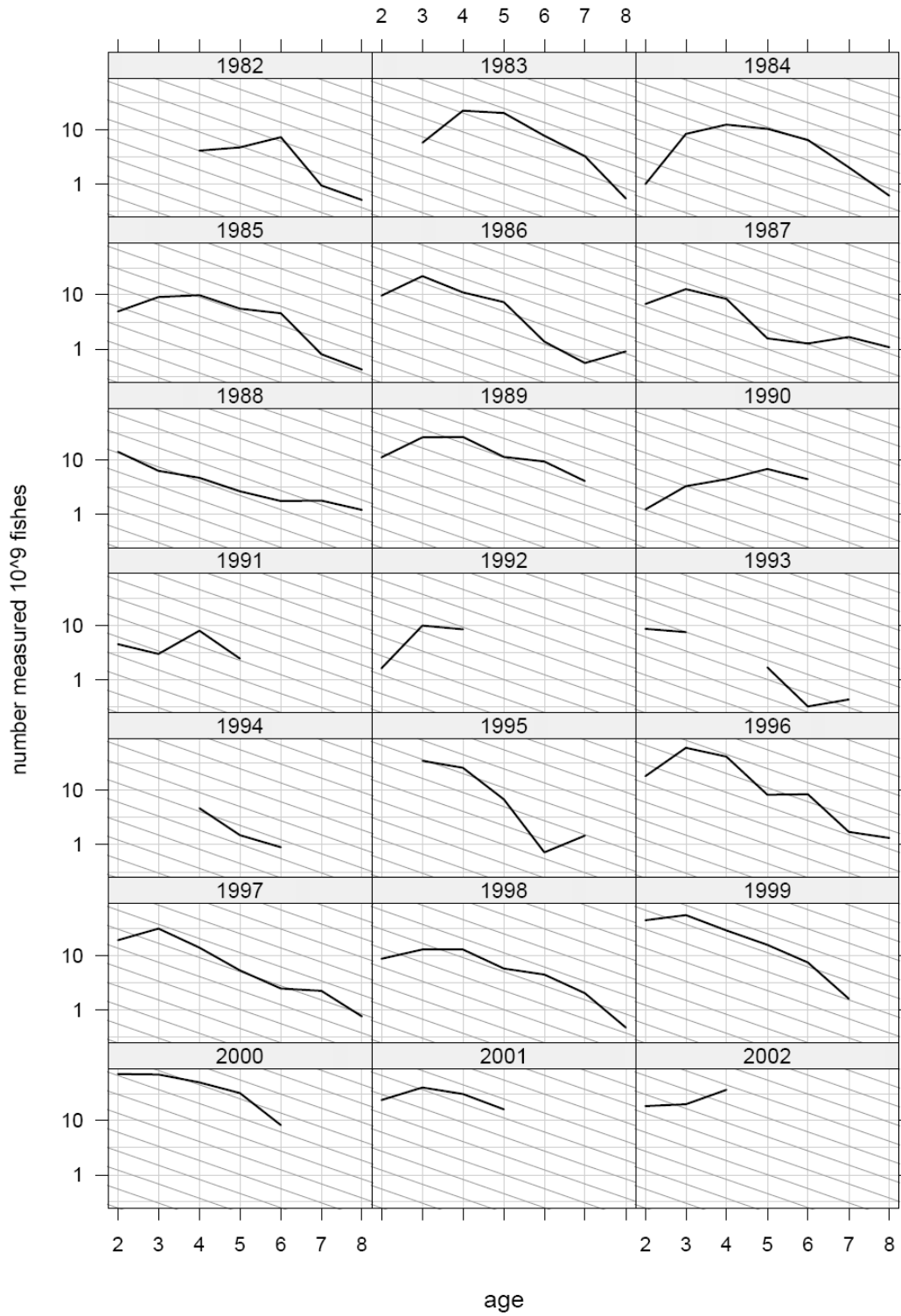

Figure 4.7.1.3 Age disaggregated abundance indices of blue whiting from the spawning survey plotted on log scale. The labels above each figure indicate yearclasses. The grey lines correspond to Z=0.6.

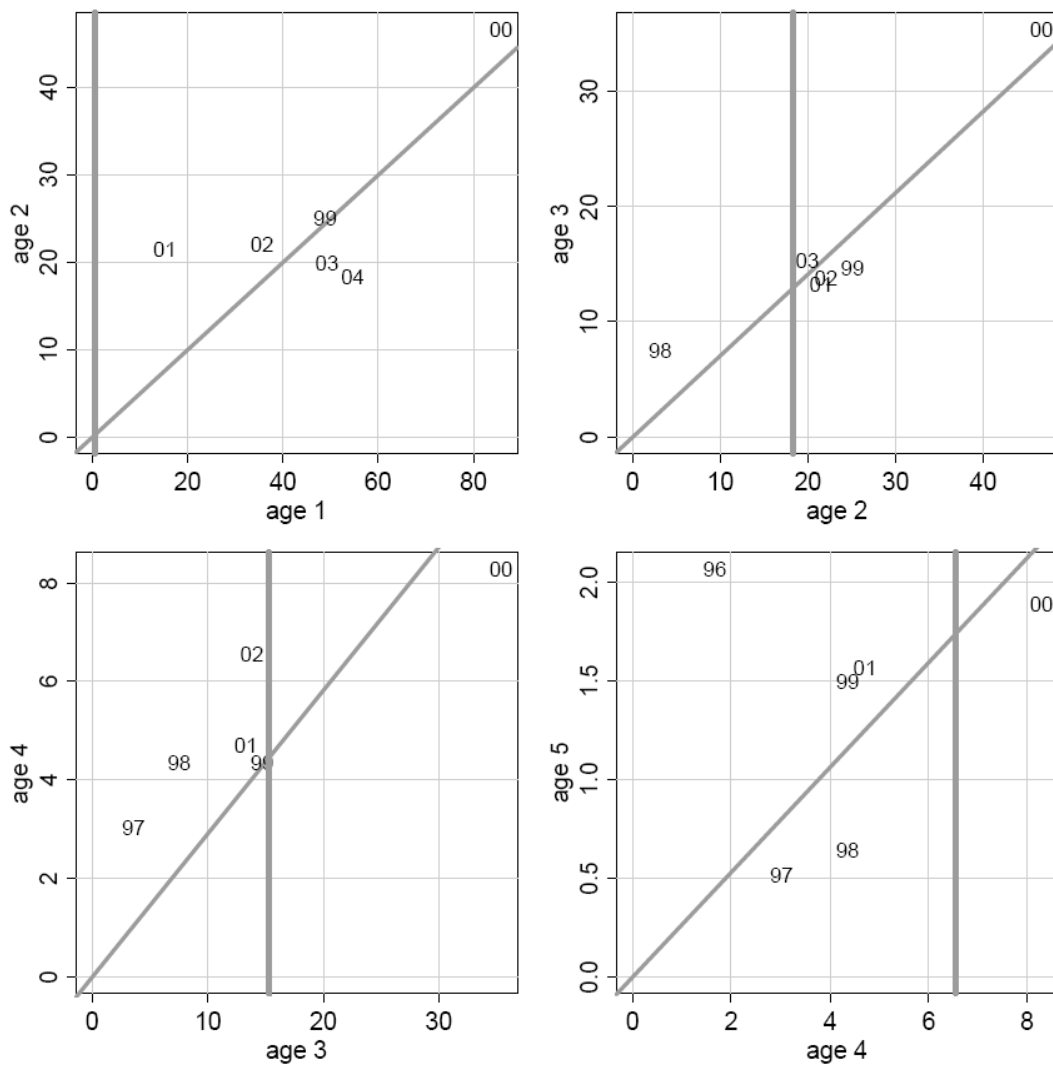

Figure 4.7.1.4. Abundance index of blue whiting in Norwegian sea survey plotted against the abundance index of the same yearclass the following year. The wide line shows the most recent estimate. The labels in the picture indicate yearclass

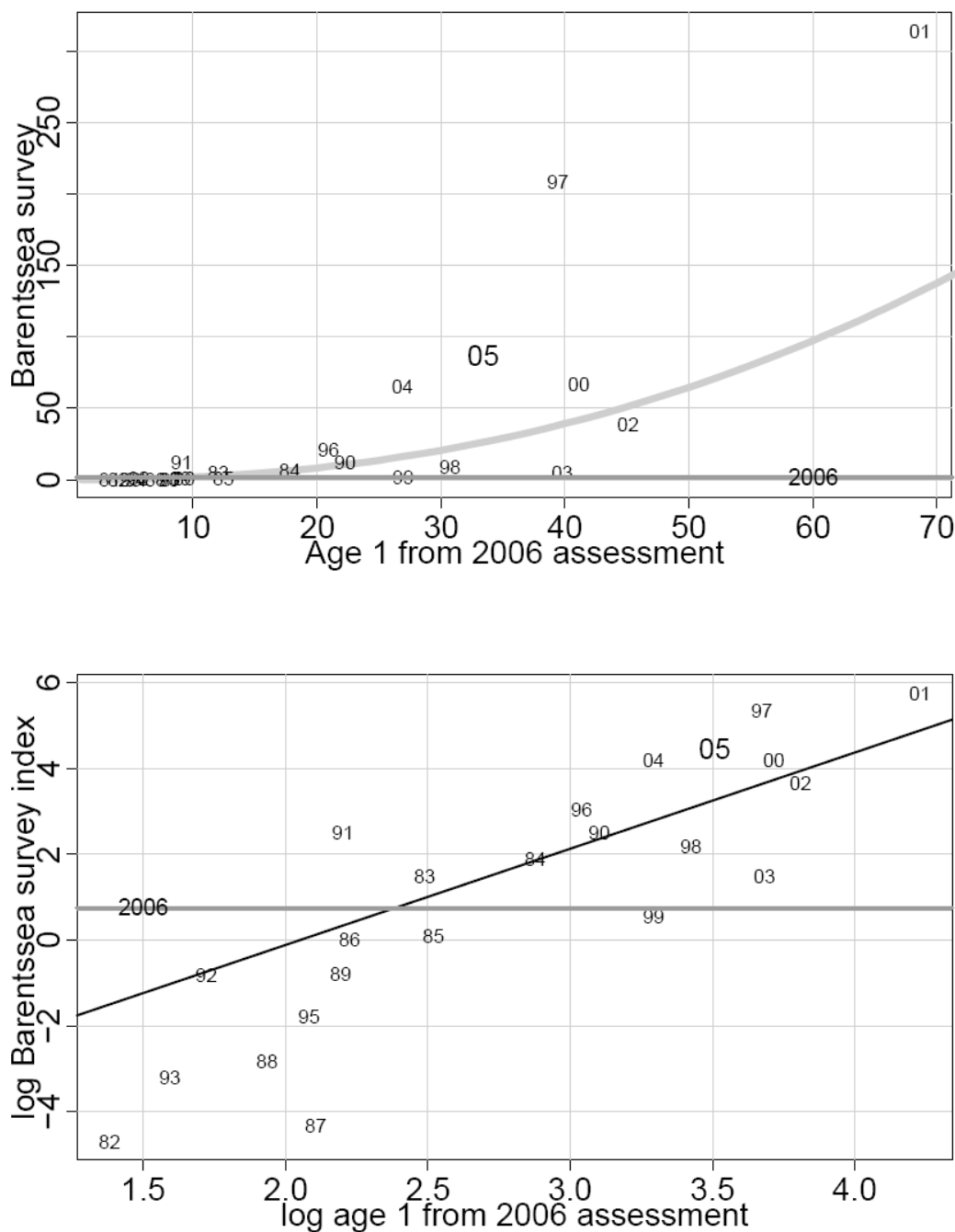

Figure 4.7.1.5 Number of age 1 blue whiting in the Barents sea survey plotted against estimate from assessment . The lines show curve fitted to the data and the horizontal lines the most recent points.

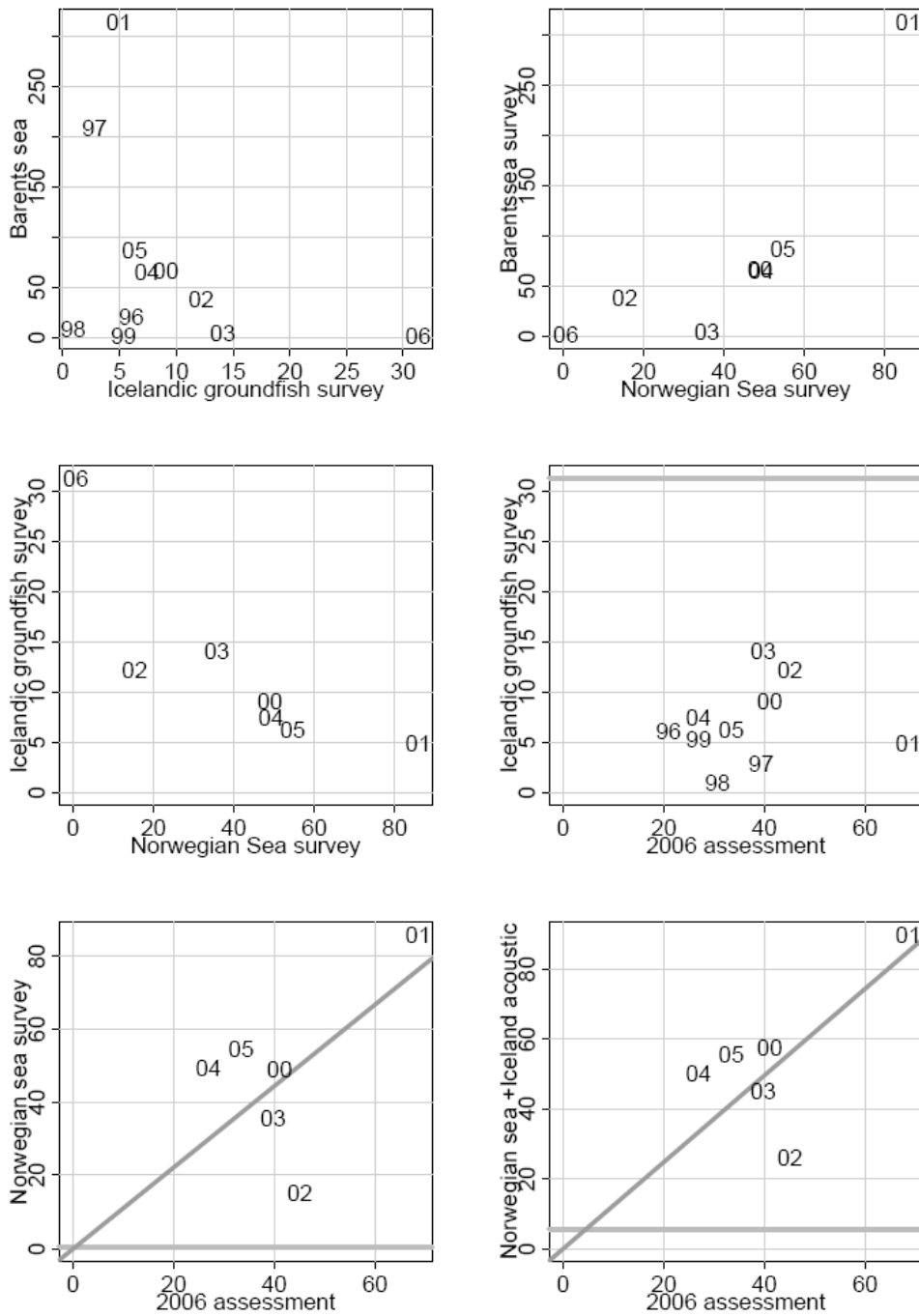

Figure 4.7.1.6 Some recruitment indices of blue whiting plotted against each other. In the upper 2 figures the label indicates year but yearclass in the lower 2.

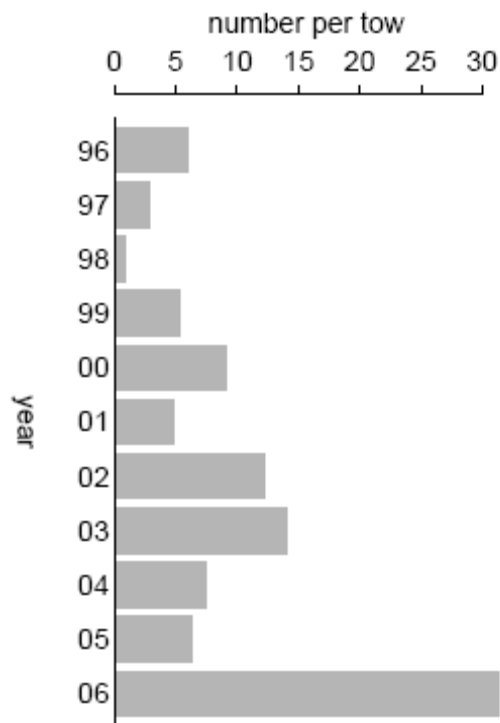

Figure 4.7.1.7 Indices of age 1 blue whiting from the Icelandic groundfish survey in March. The indices are calculated as the mean number of fish smaller than 21 cm in each tow using the area covered by the survey in all years.

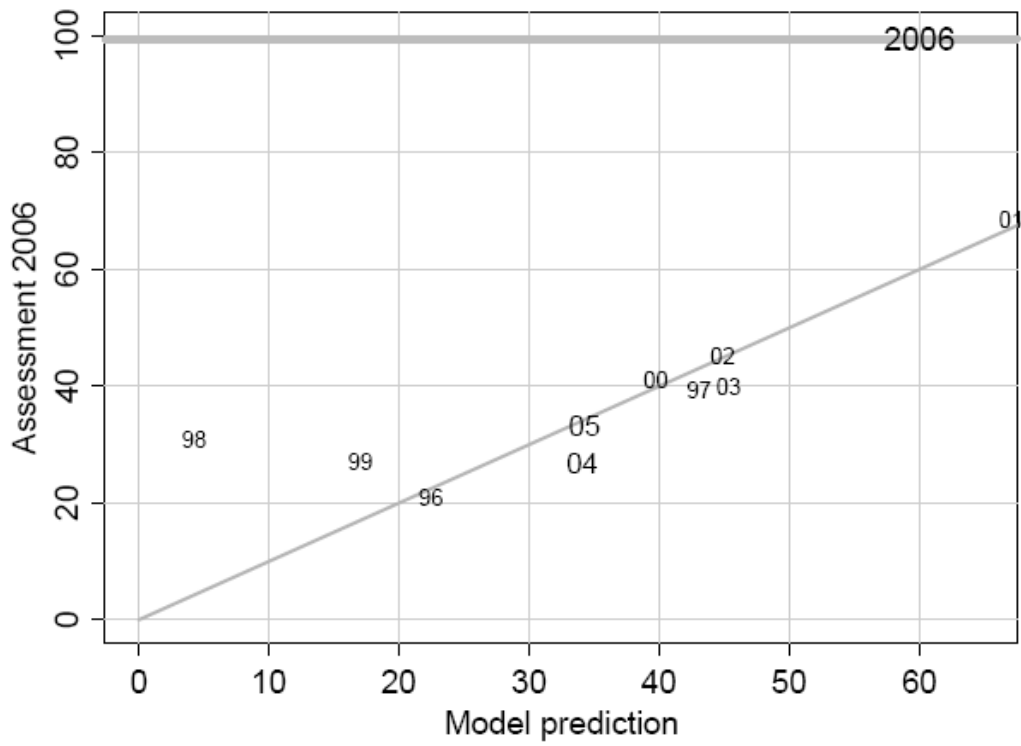

Figure 4.7.1.8 Blue whiting. Prediction of recruitment from a model $N_1 = \alpha I_{ice} + \beta I_{bar}$. Labels in the figure indicate year. The horizontal line shows the estimate for the 2005 yearclass and the slope line 1-1 relationship so points on that line fit perfectly.

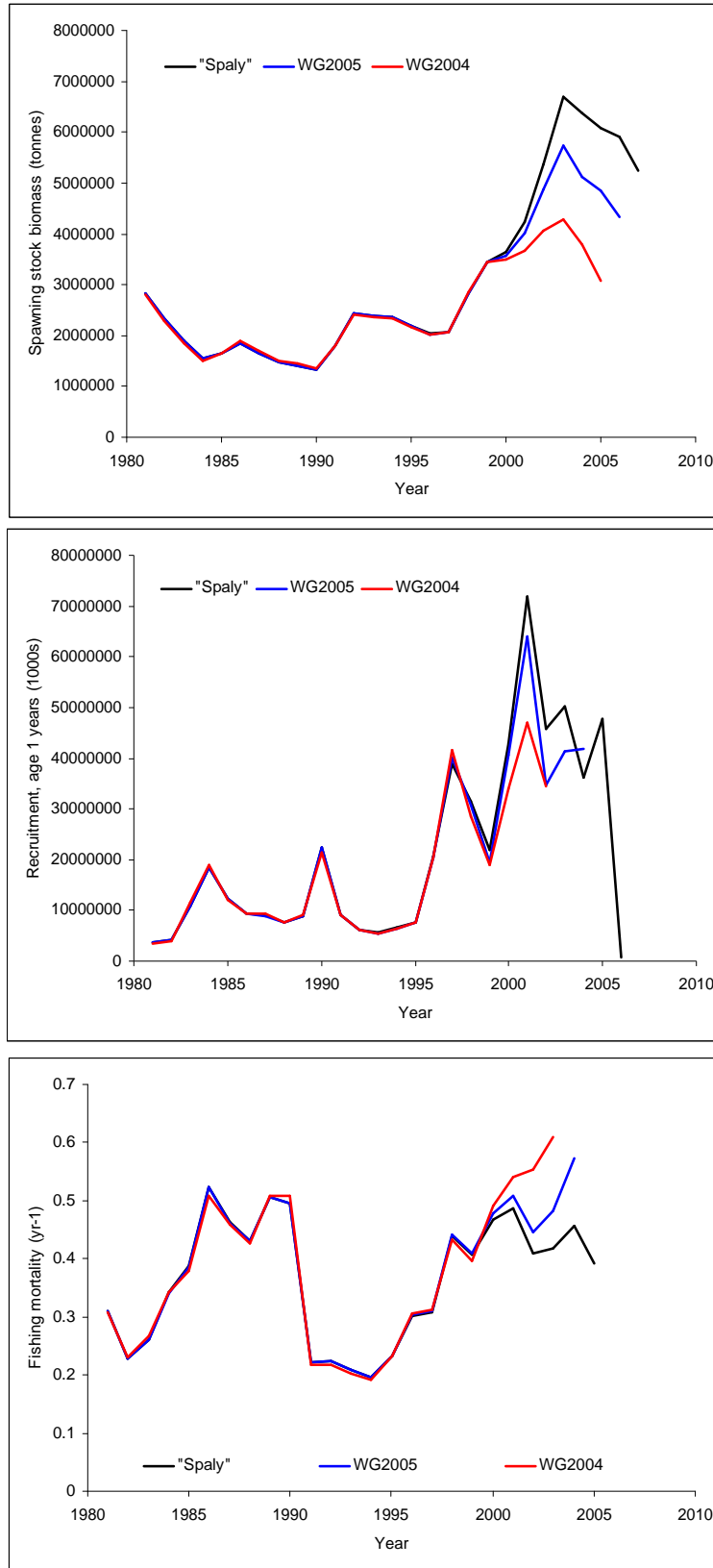

Figure 4.7.2.1. Blue whiting. Comparison of the final AMCI assessment in 2004–2005 and new assessment with the settings similar to the 2005 ones (recruitment in the terminal year is estimated in the current assessment but was guesstimated in 2005) and updated data.

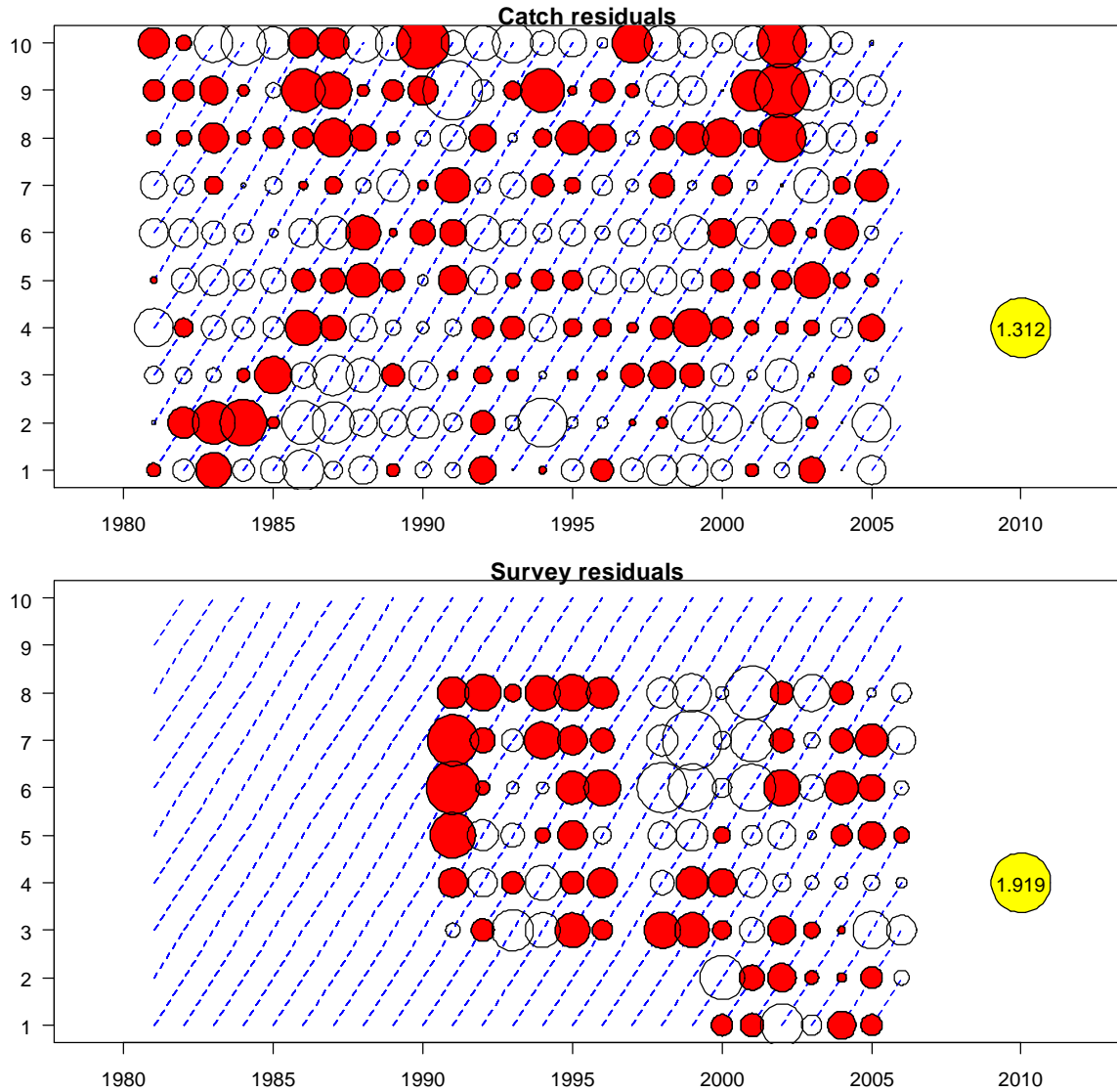

Figure 4.7.2.2. Blue whiting. Residuals from the final AMCI run. In the lower panel, residuals from two surveys are plotted in the same figure: Norwegian spawning stock survey (ages 3-8 years) and international Norwegian Sea ecosystem survey (ages 1-2 years).

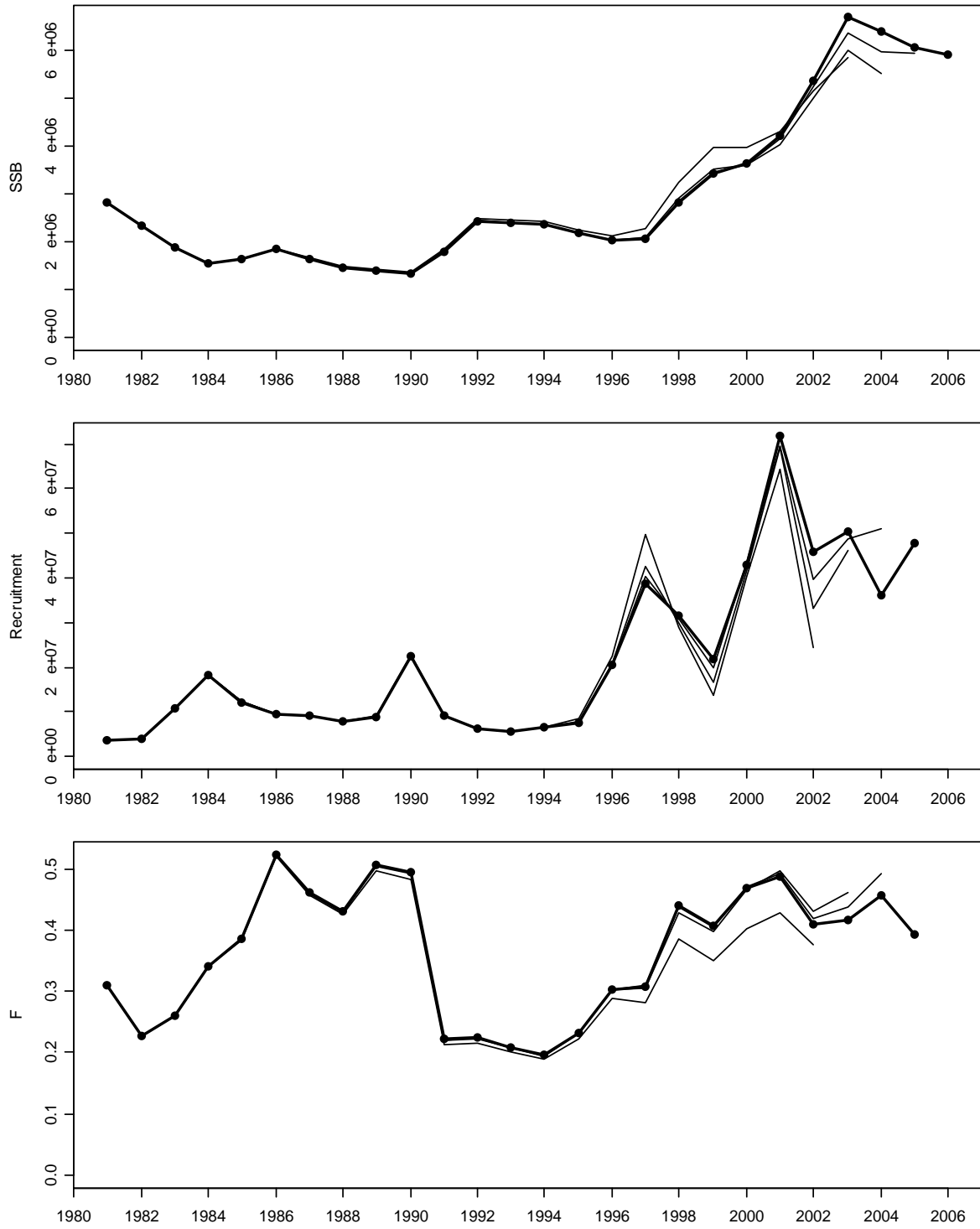

Figure 4.7.2.3. Blue whiting. Retrospective analysis on the final AMCI assessment. The terminal year is varied from 2003 to 2006.

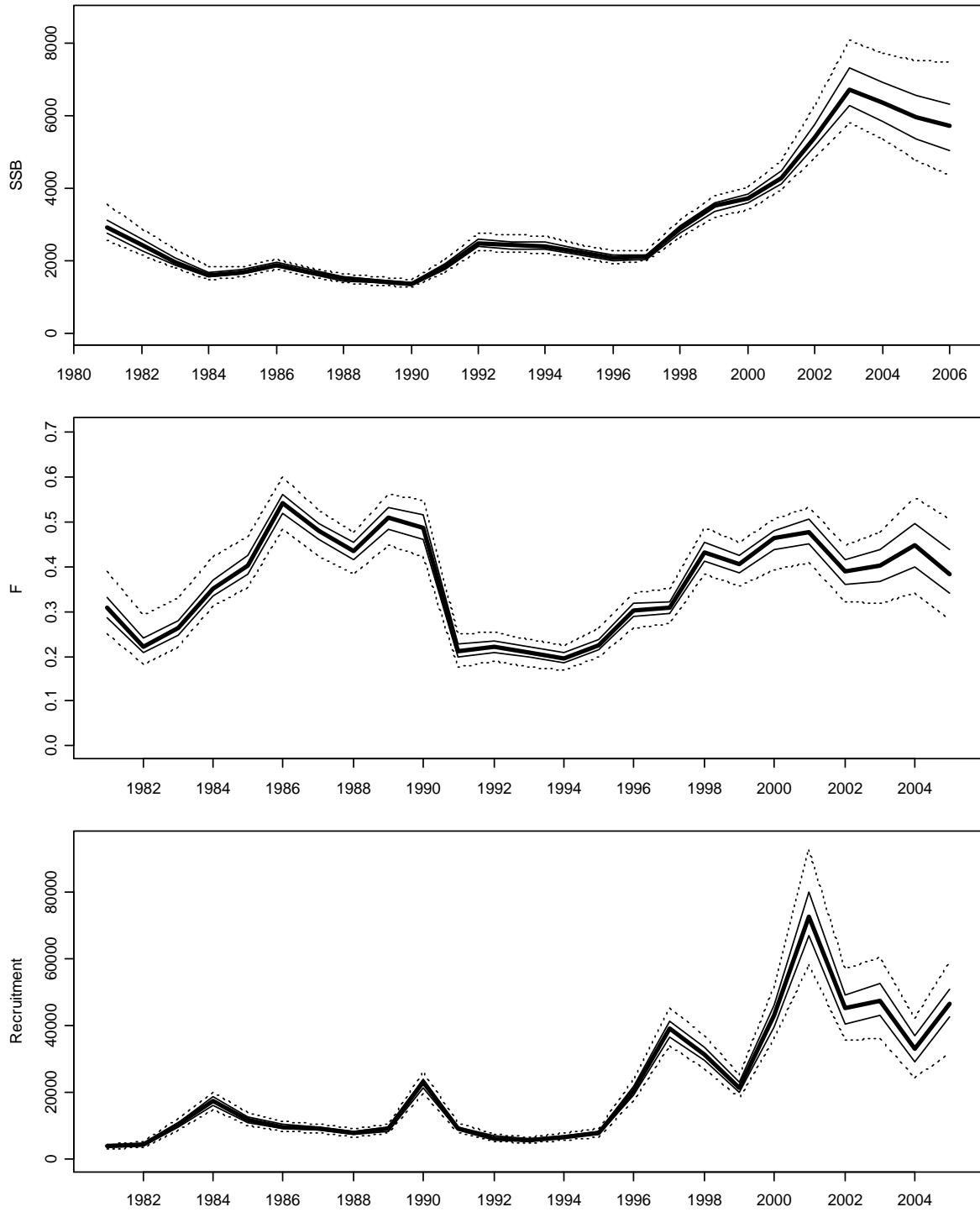

Figure 4.7.2.4. Blue whiting. Results from bootstrapping the final AMCI assessment (500 replicates).

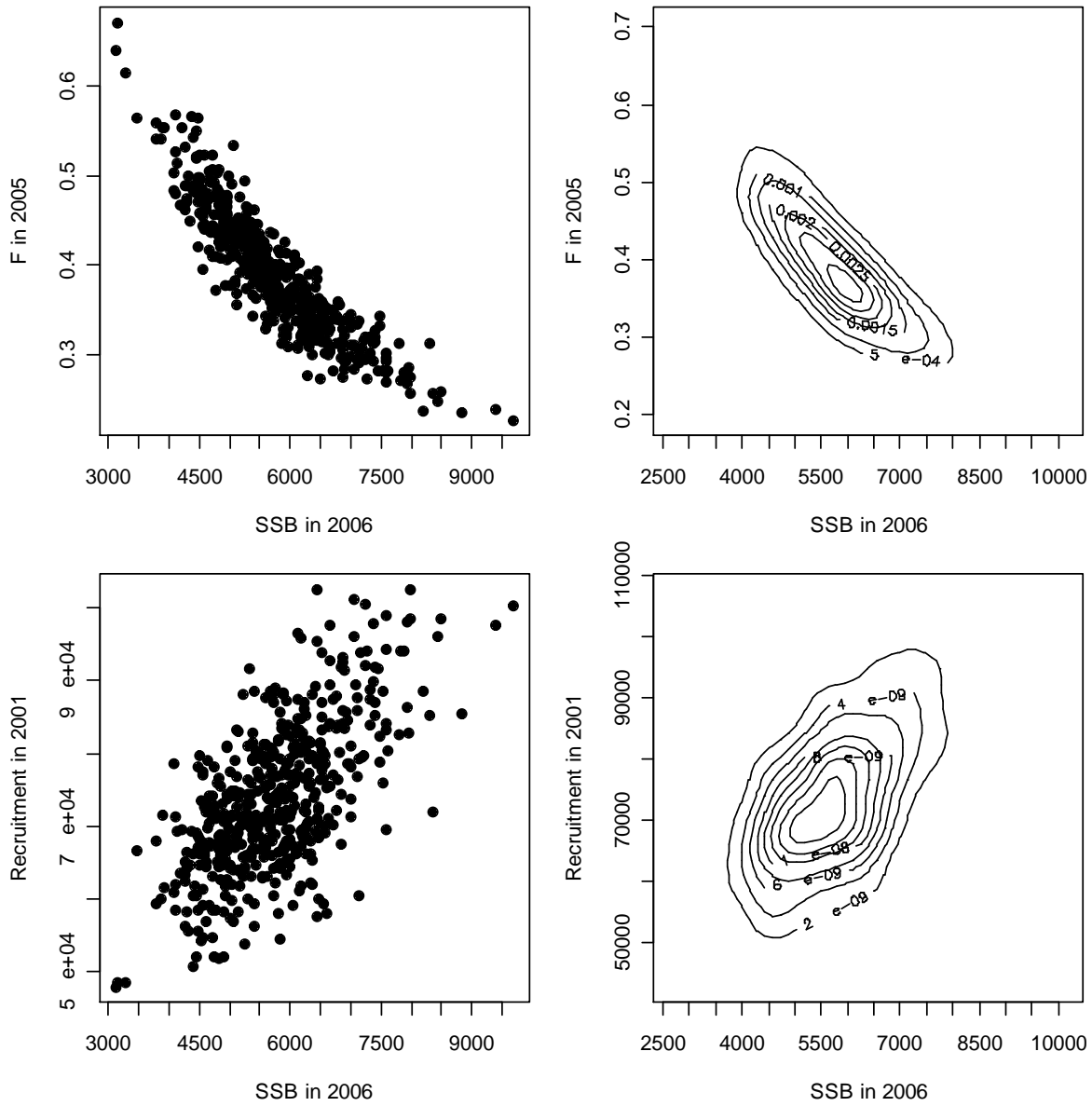

Figure 4.7.2.5. Blue whiting. Results from bootstrapping the final AMCI assessment (500 replicates). These graphs show interdependence between the estimate of fishing mortality in the final year and SSB in the end of the final year. SSB in the end of the final year is also strongly correlated with recruitment in 2001.

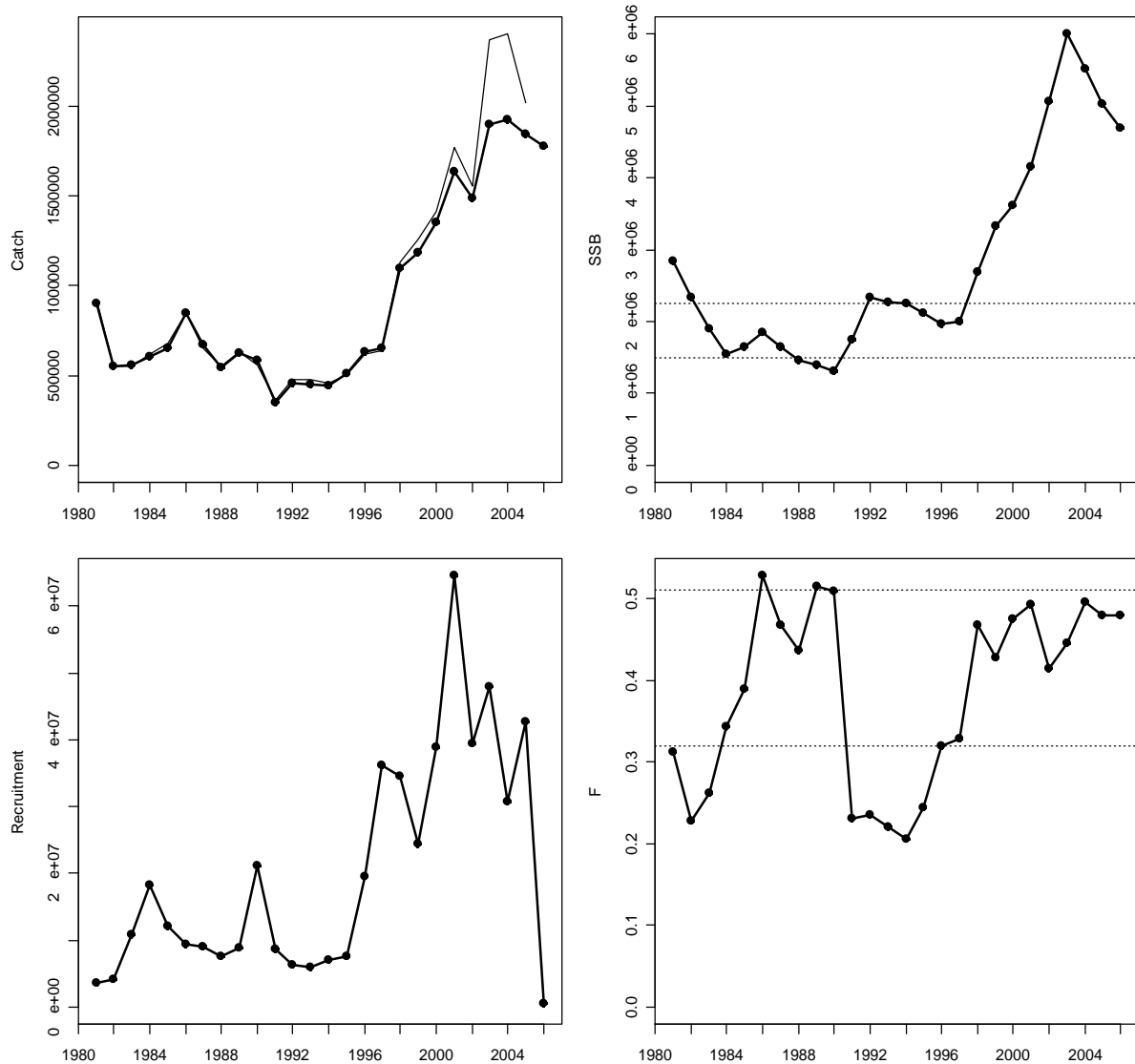
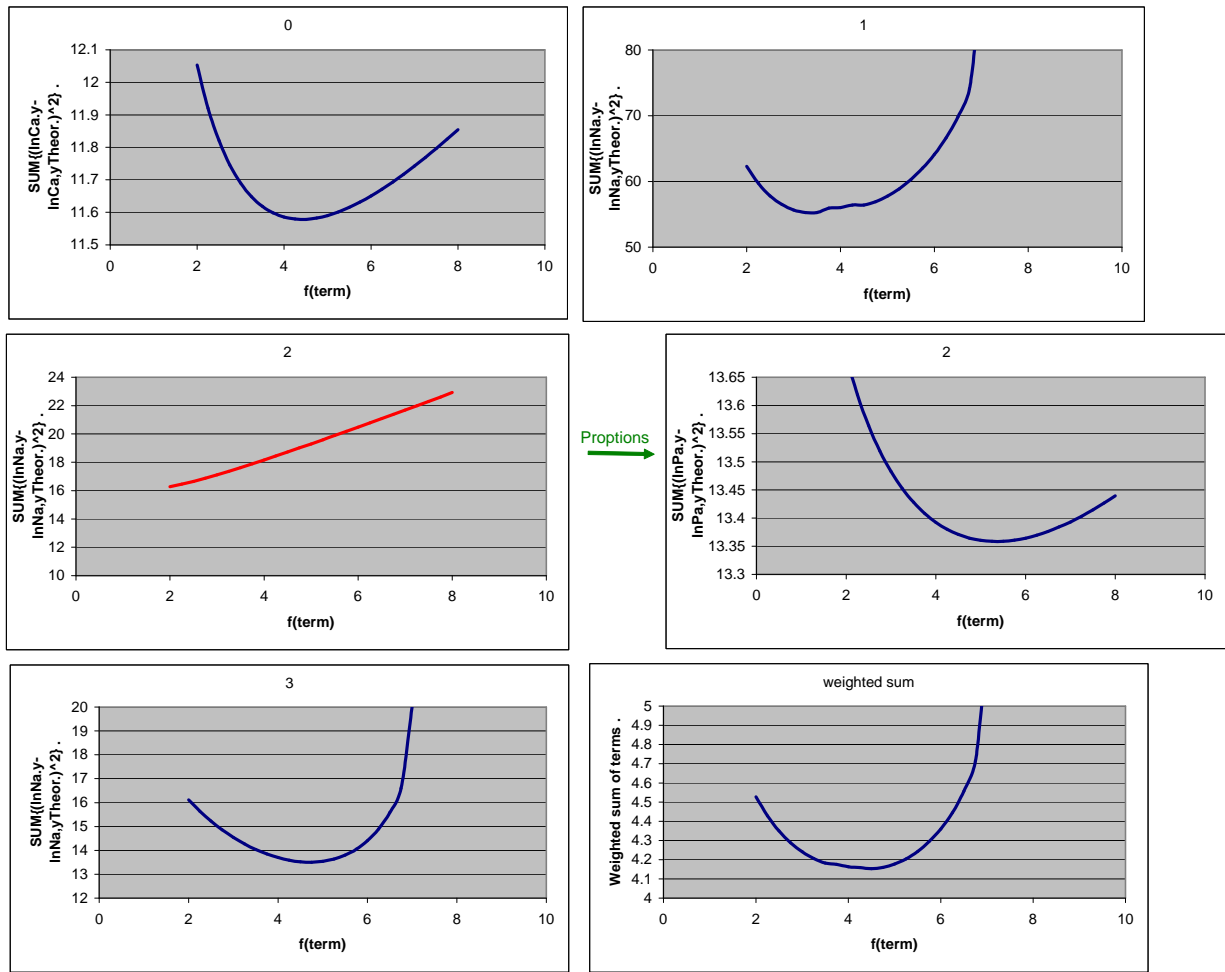

Figure 4.7.2.6. Blue whiting. Exploratory AMCI assessment in which Norwegian catches from the directed fishery in IIa and the mixed industrial fishery in IIa-IVa are treated as a separate catch fleet for the period 2000–2005 (earlier data were not easily available).



- 0 - signal from catch-at-age
- 1 - signal from Norway spawning acoustic (91-2006)
- 2 - signal from Nsea May acoustic (2000-2006)
- 3 - signal from March international acoustic (2004-2006)

Figure 4.7.3.1 BW. Profiles of components of the TISVPA loss function

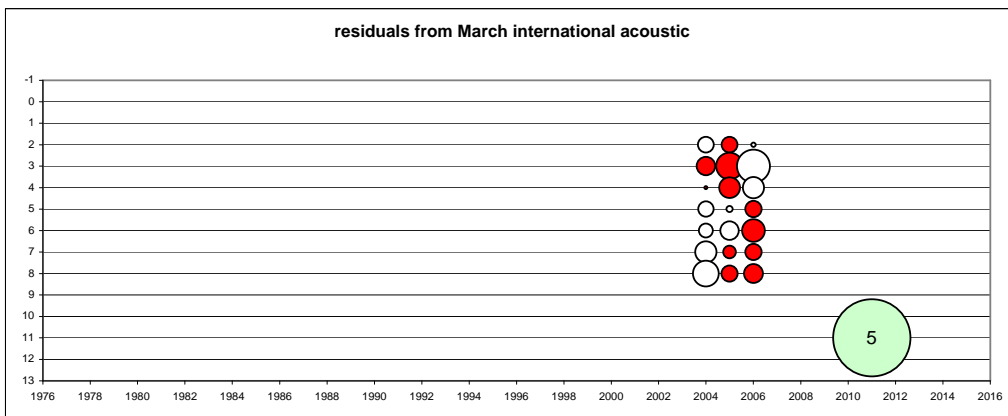
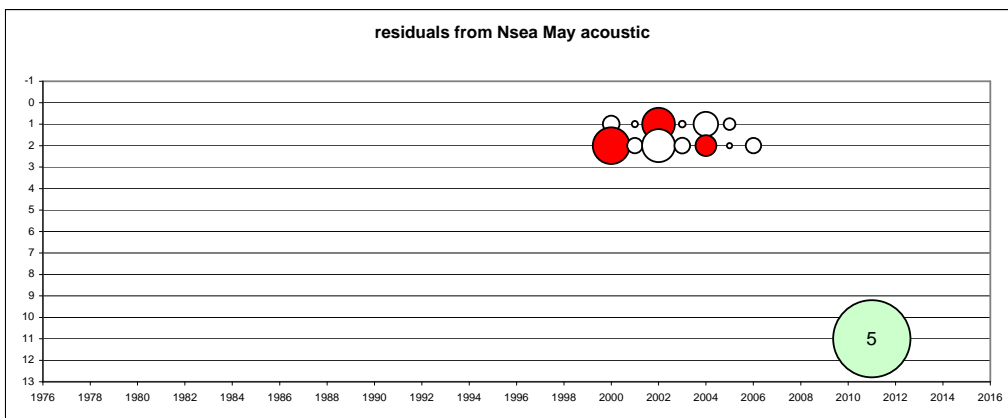
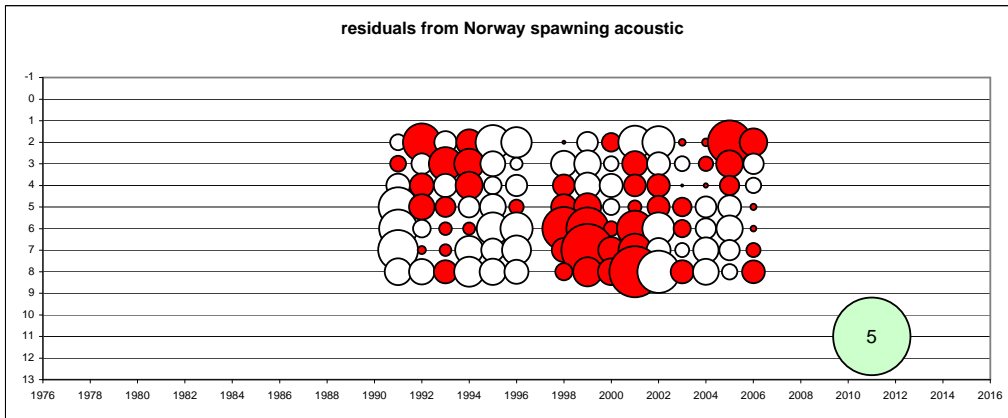
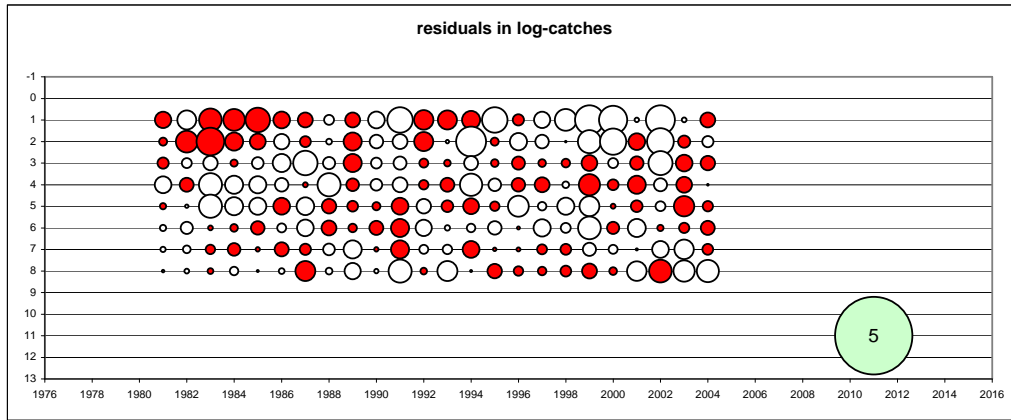

Figure 4.7.3.2. BW. The TISVPA residuals

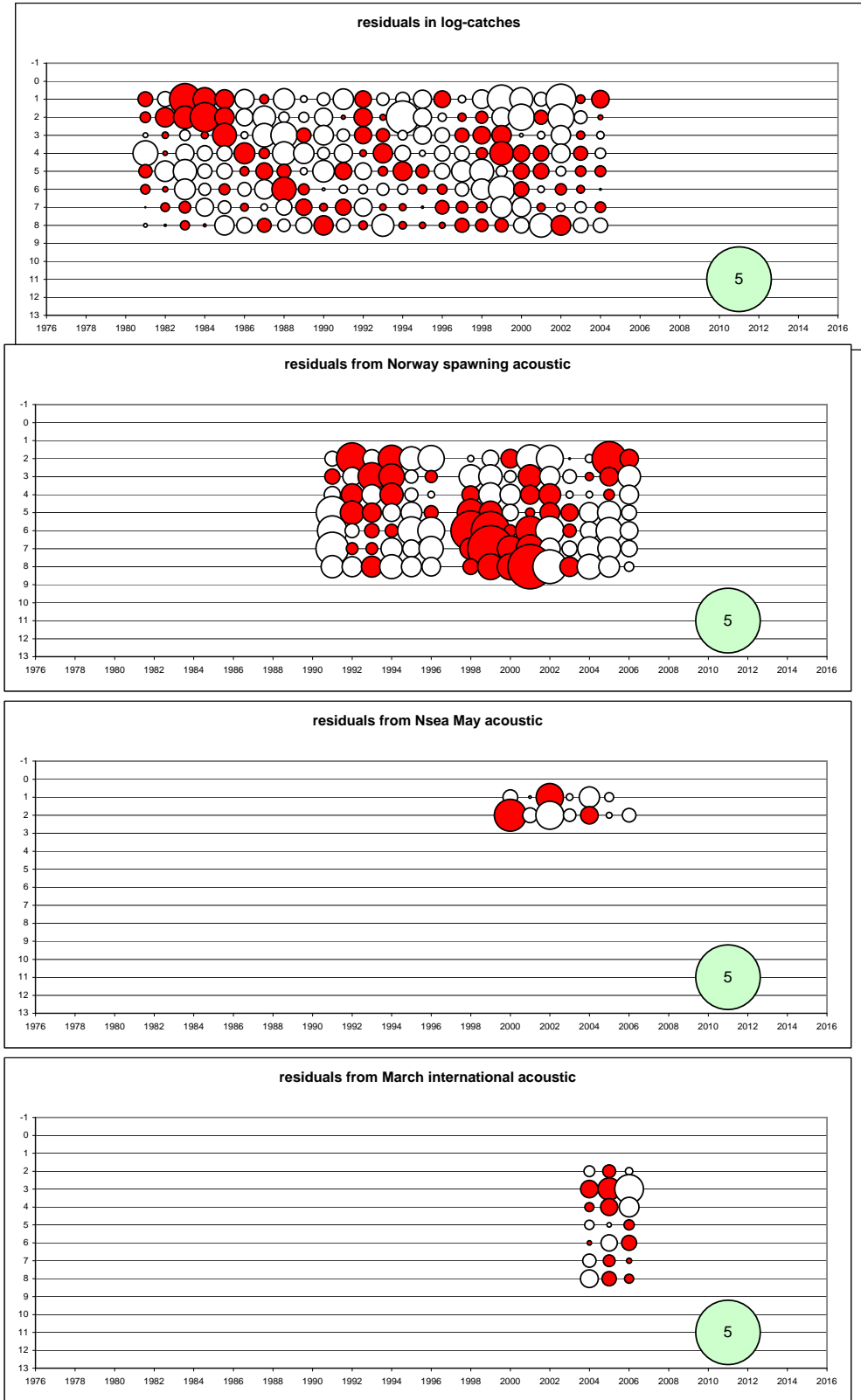

Figure 4.7.3.3. BW.The residuals for “ordinary” ISVPA.

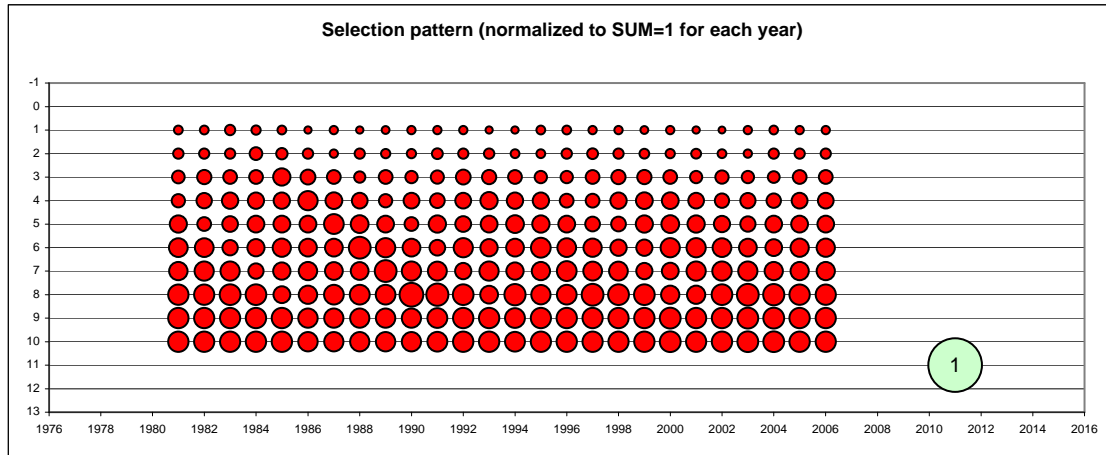

Figure 4.7.3.4. TISVPA-derived selection matrix for blue whiting

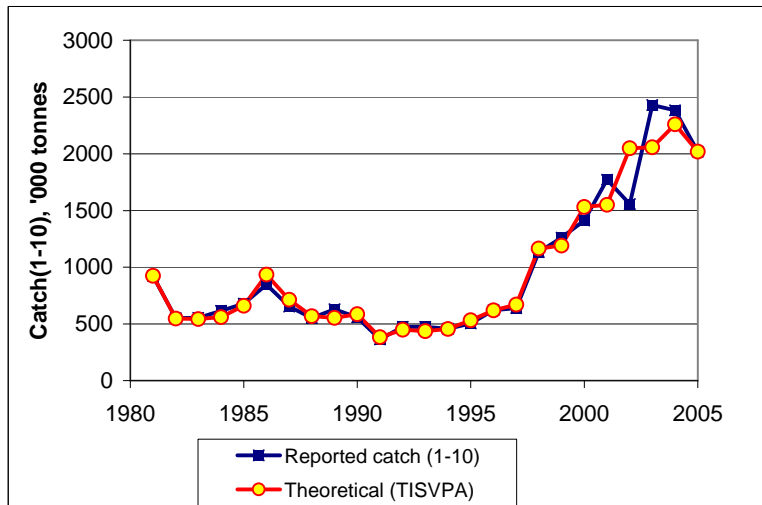

Figure 4.7.3.5. BW. Comparison of reported and TISVPA-derived theoretical catches

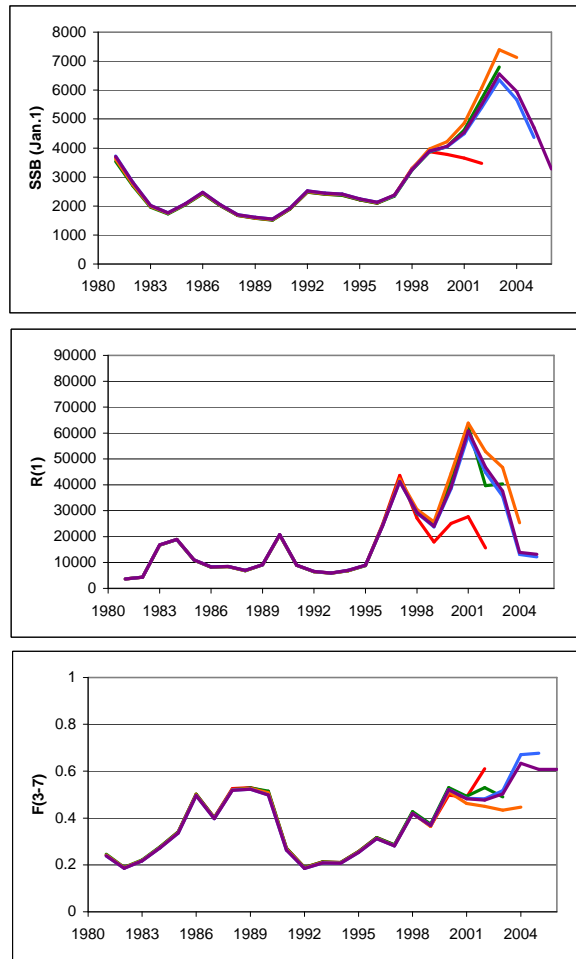

Figure 4.7.3.6 BW. TISVPA retrospective runs

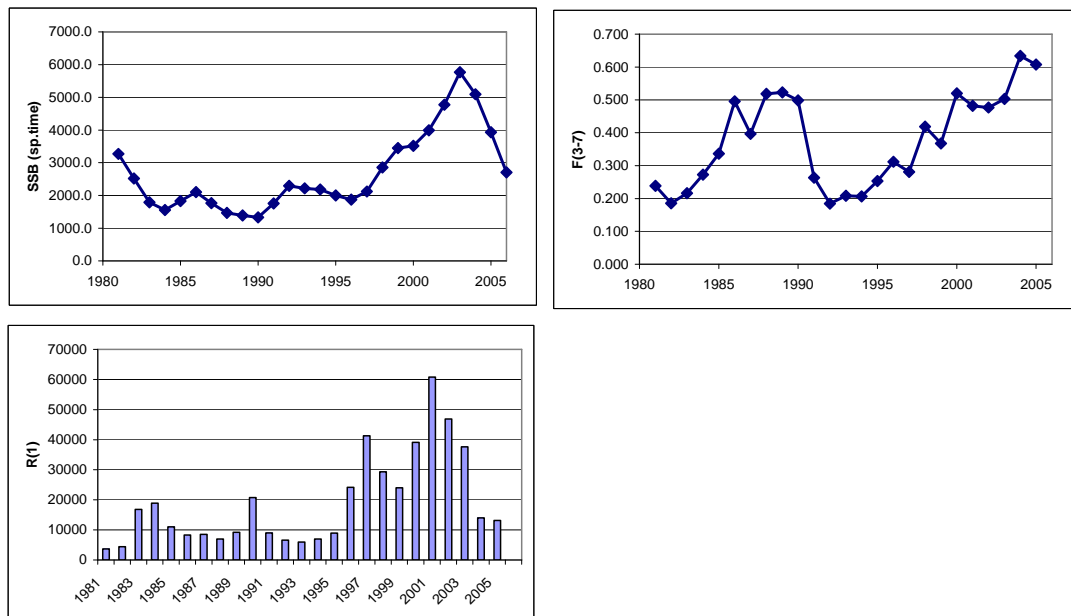

Figure 4.7.3.7. Blue whiting. TISVPA results

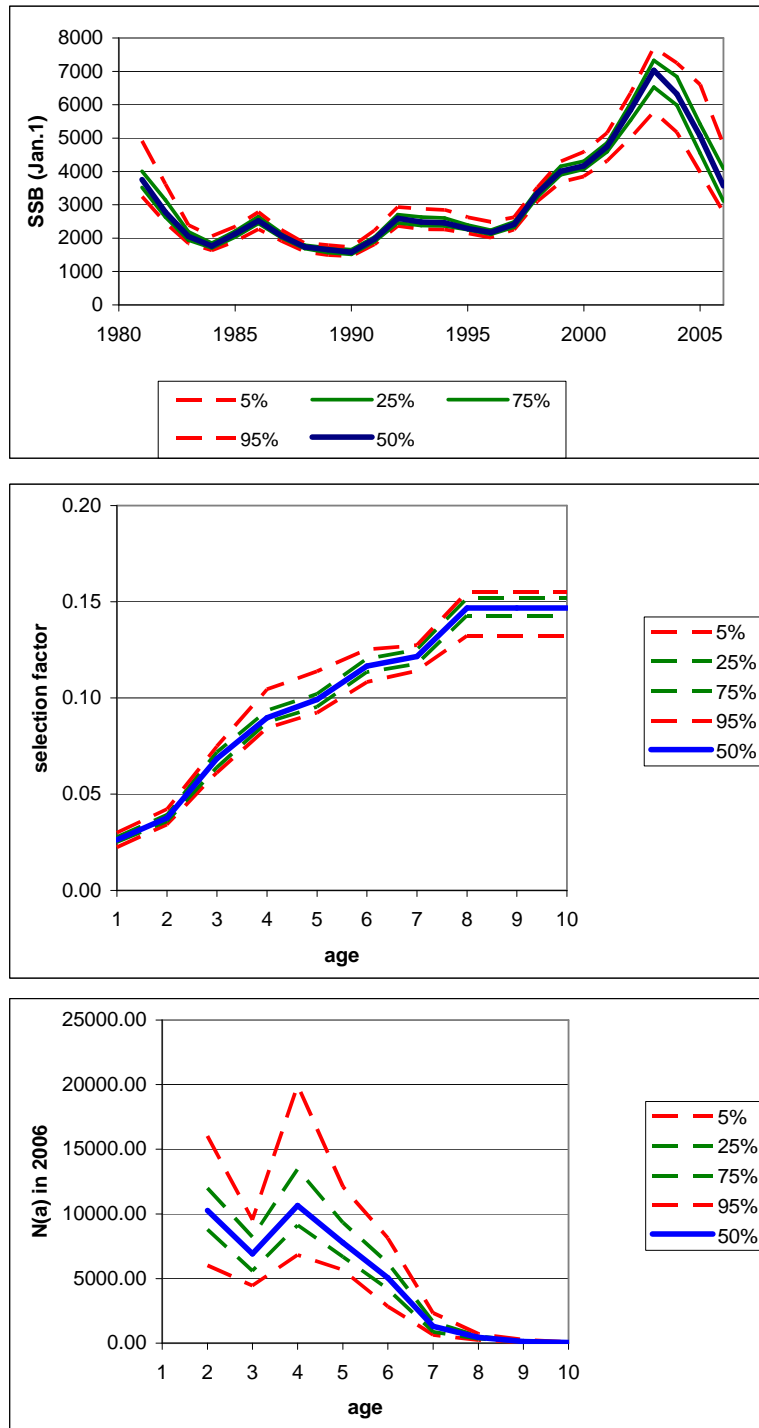

Figure 4.7.3.8. Blue whiting. TISVPA. Bootstrap.

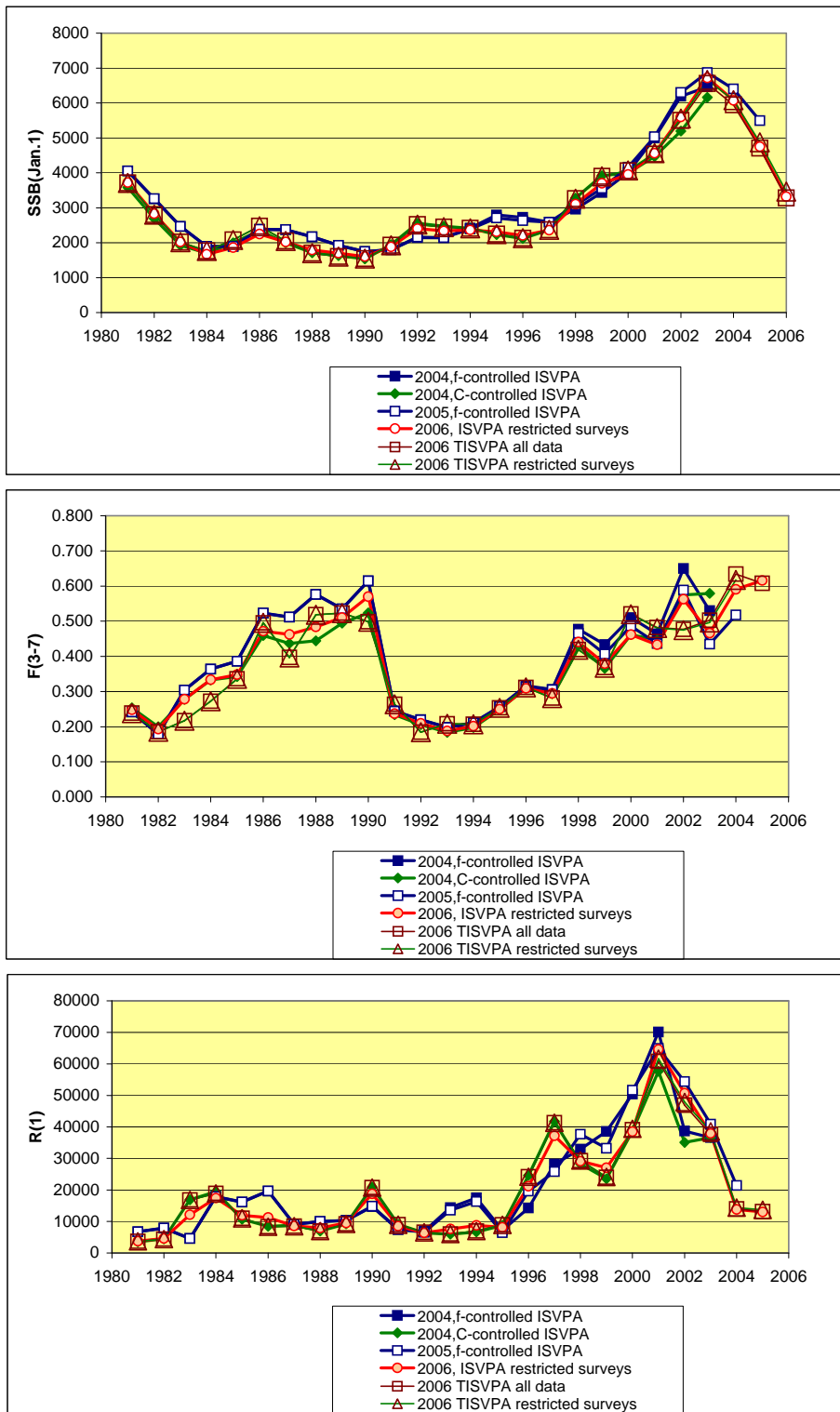

Figure 4.7.3.9. Comparison of the ISVPA (TSVPA) results with results of previous blue whiting

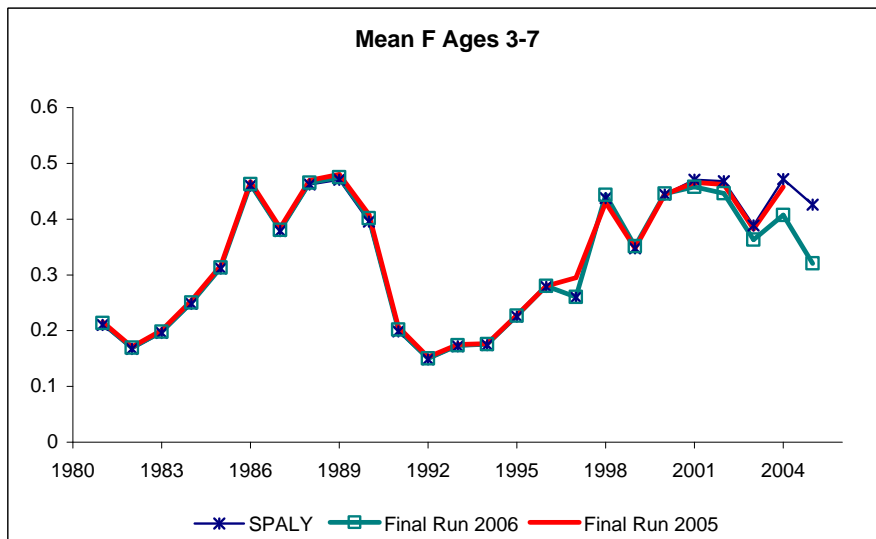
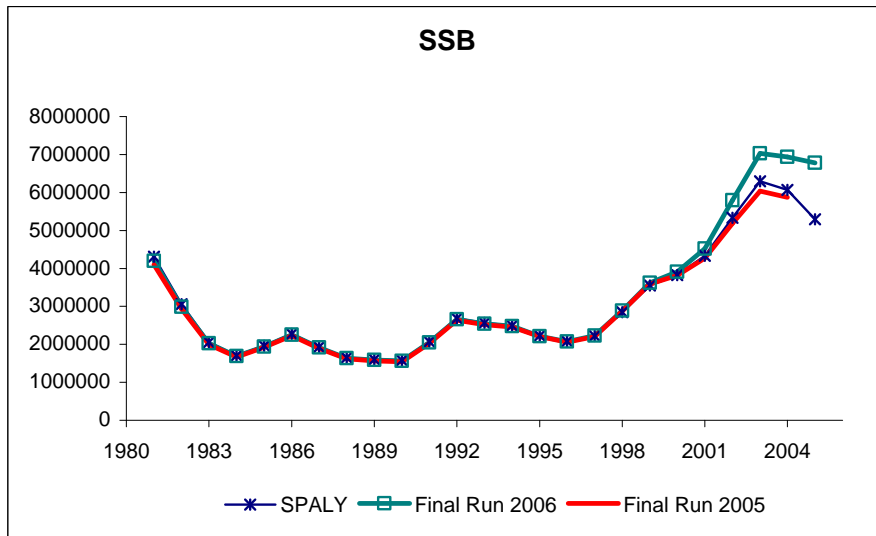
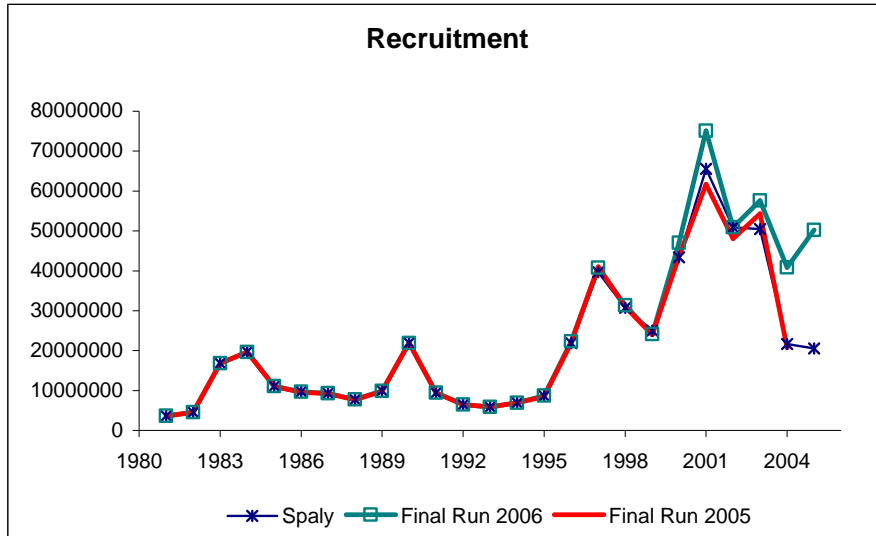

Figure 4.7.4.1. Blue Whiting. Comparison of the final ICA Run 2005, 2006 and Run 1 (SPALY: the same procedure as last year) with the same settings and updated data

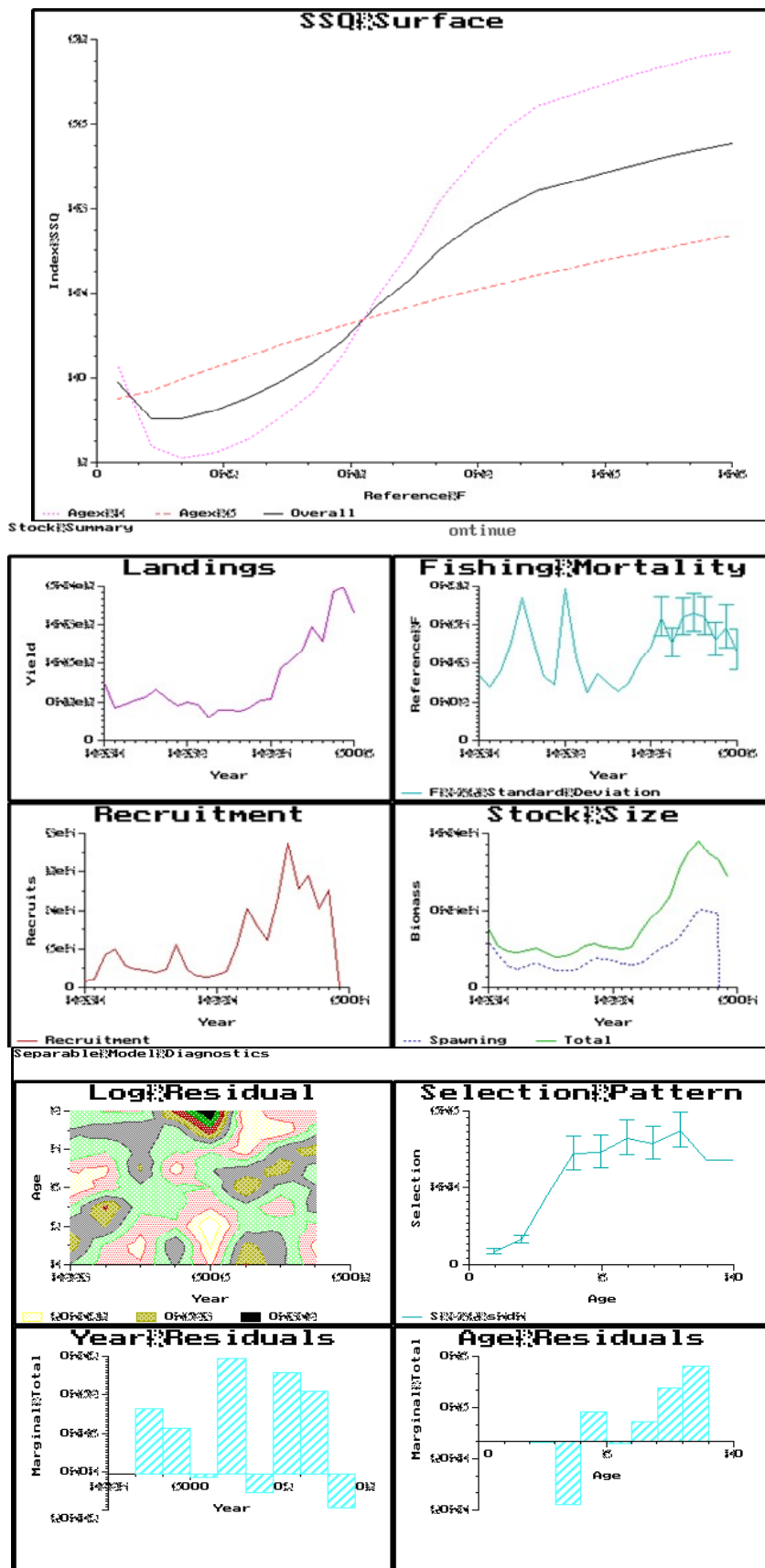

Figure 4.7.4.2. SSq surface plot, and standard plots for final ICA run for blue whiting in 2006.

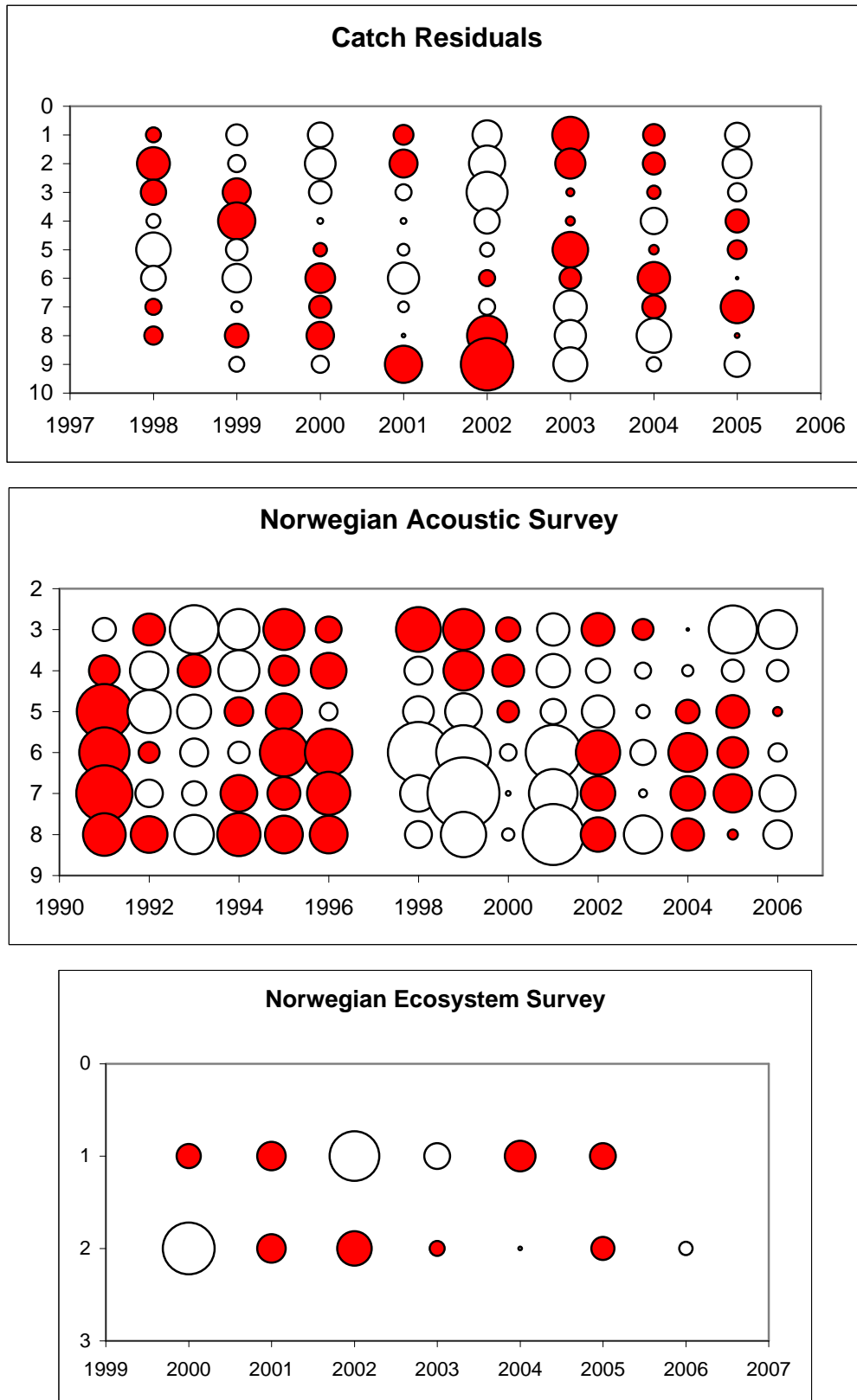

Figure 4.7.4.3. Residual plots for catches and survey data for blue whiting, final run 7 WG 2006

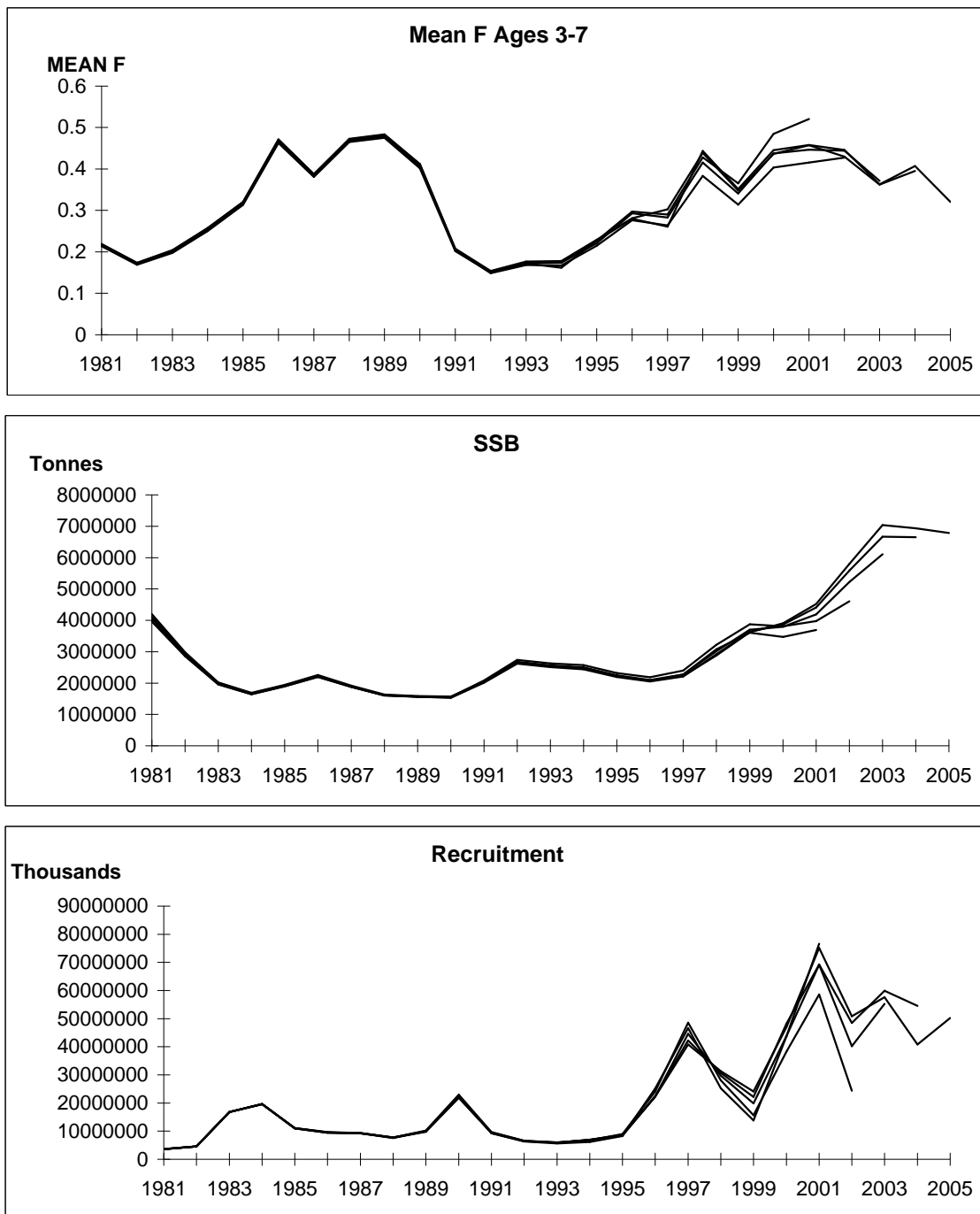

Figure 4.7.4.4. Retrospective ICA runs to 2001 using settings for final run 2006

Figure 4.7.4.4 BW. Retrospective ICA runs to 2001 using settings for final run 2006

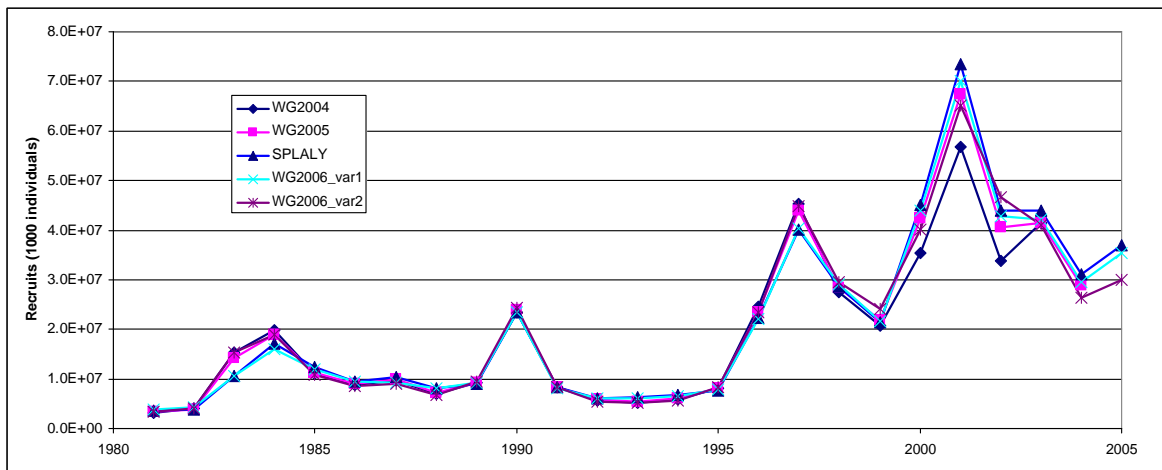
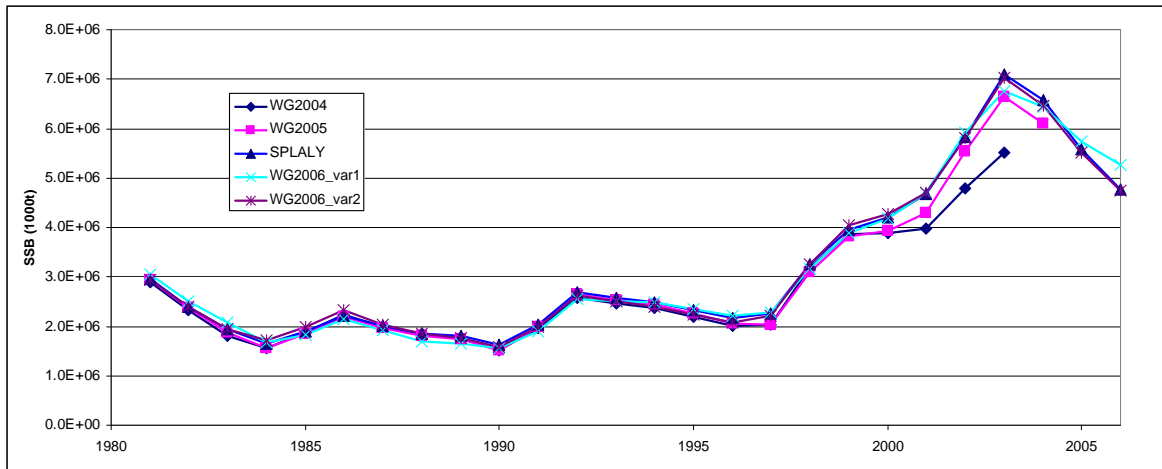
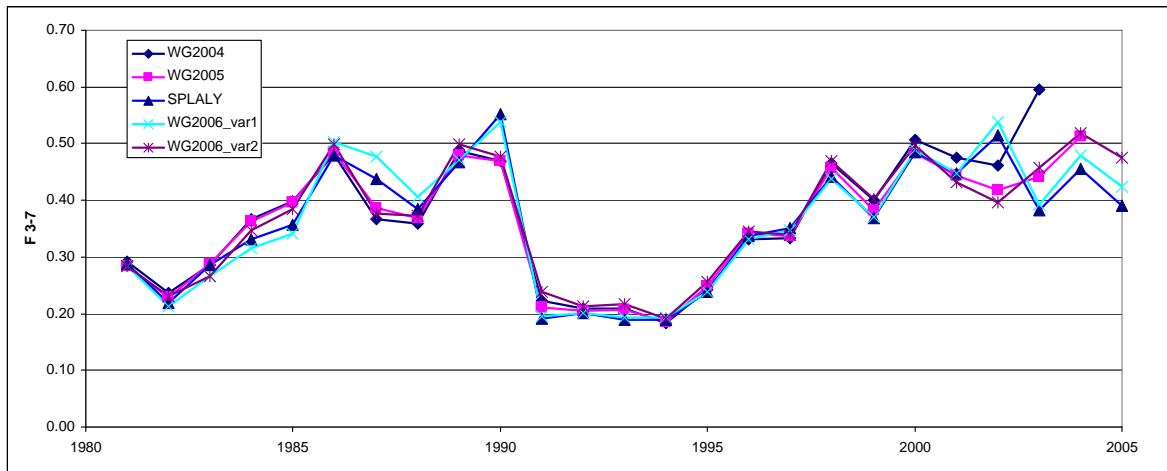

Figure 4.7.5.1 Blue Whiting, SMS. Presentation of previous year's SMS results, SPALY and 2006 exploratory runs (WG2006_var1 bounded CV, var2 unbounded CV at catch at age observation).

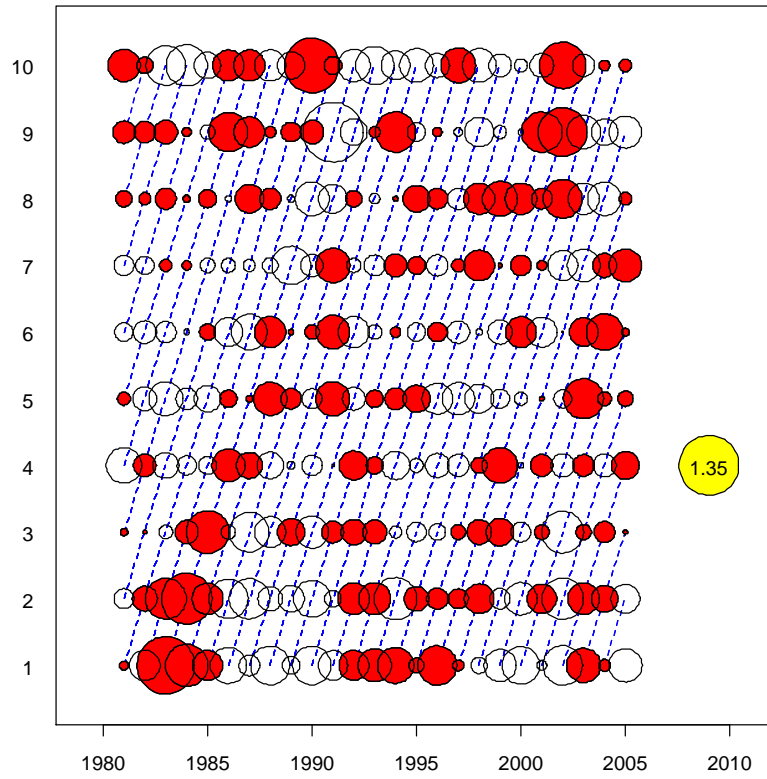

Figure 4.7.5.2 Blue Whiting, SMS. Catch residuals for run with bounds (25%) on CV of catch observations

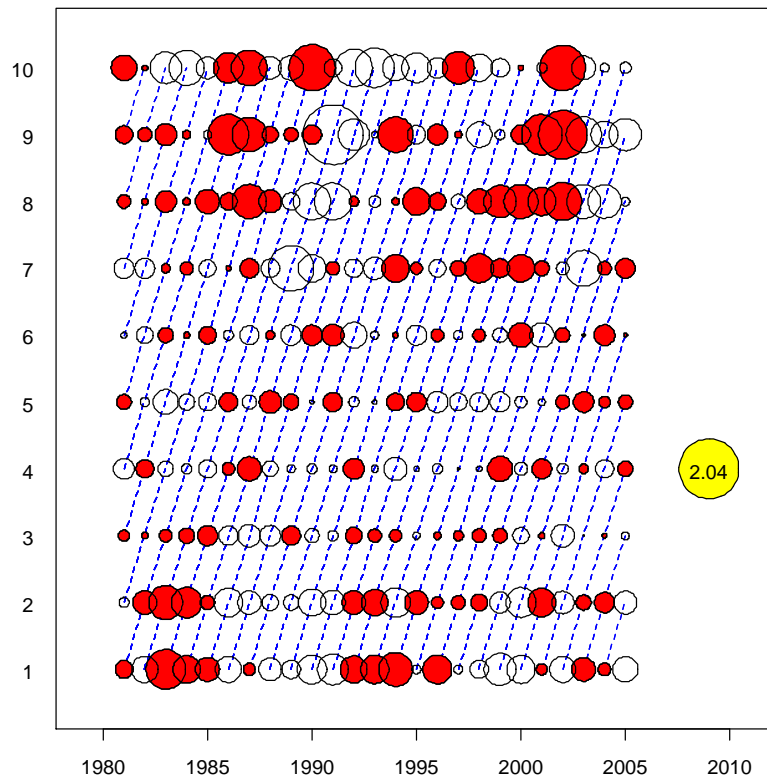

Figure 4.7.5.3 Blue Whiting, SMS. Catch residuals for run without bounds on CV of catch observations

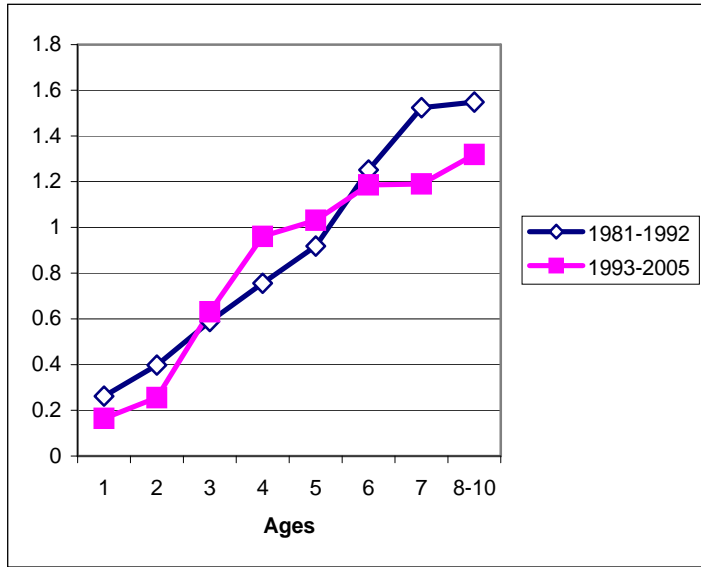

Figure 4.7.5.4 Blue Whiting, SMS exploratory run, Selection pattern for blue whiting (each series is scaled to 1 for the mean F age range 3-7)

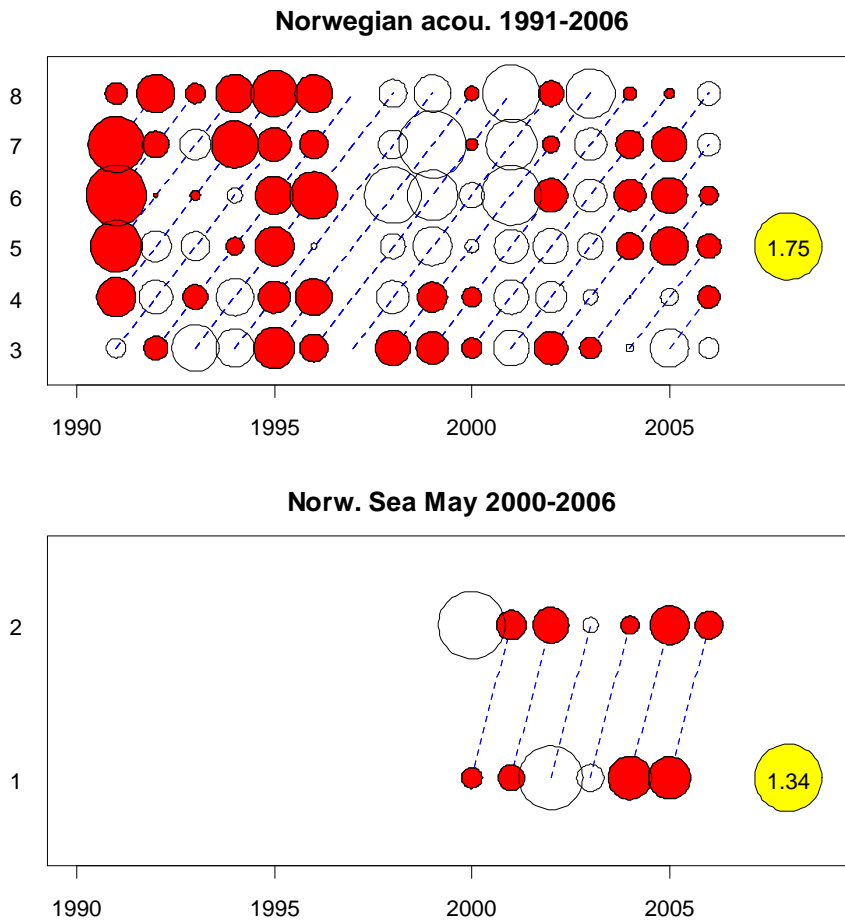

Figure 4.7.5.5 Blue Whiting, SMS exploratory run, residuals for survey observations. Red (dark) bubbles show that the observed value is bigger than the expected value.

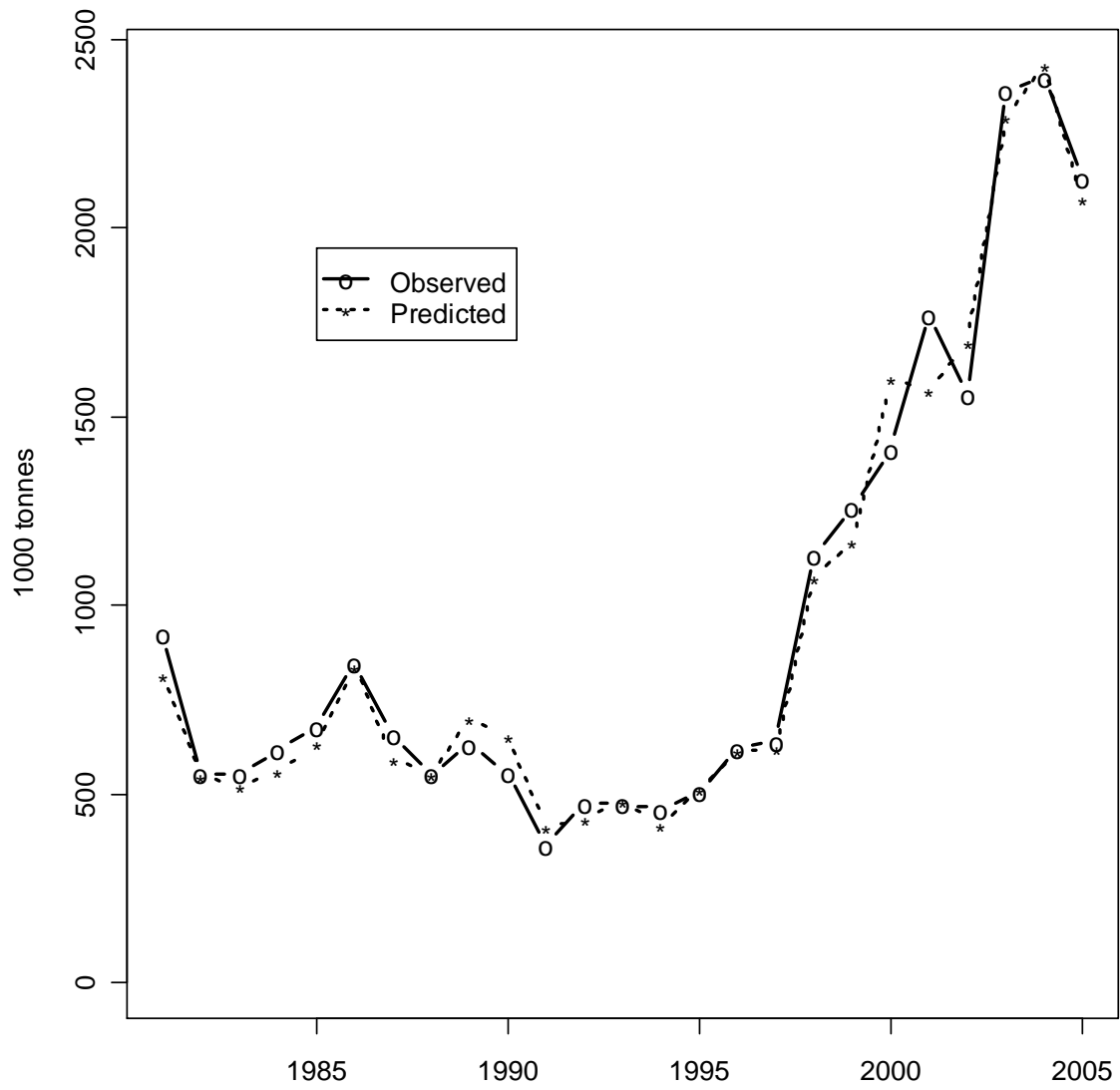

Figure 4.7.5.6 Blue Whiting, SMS exploratory run, Observed and predicted Yield.

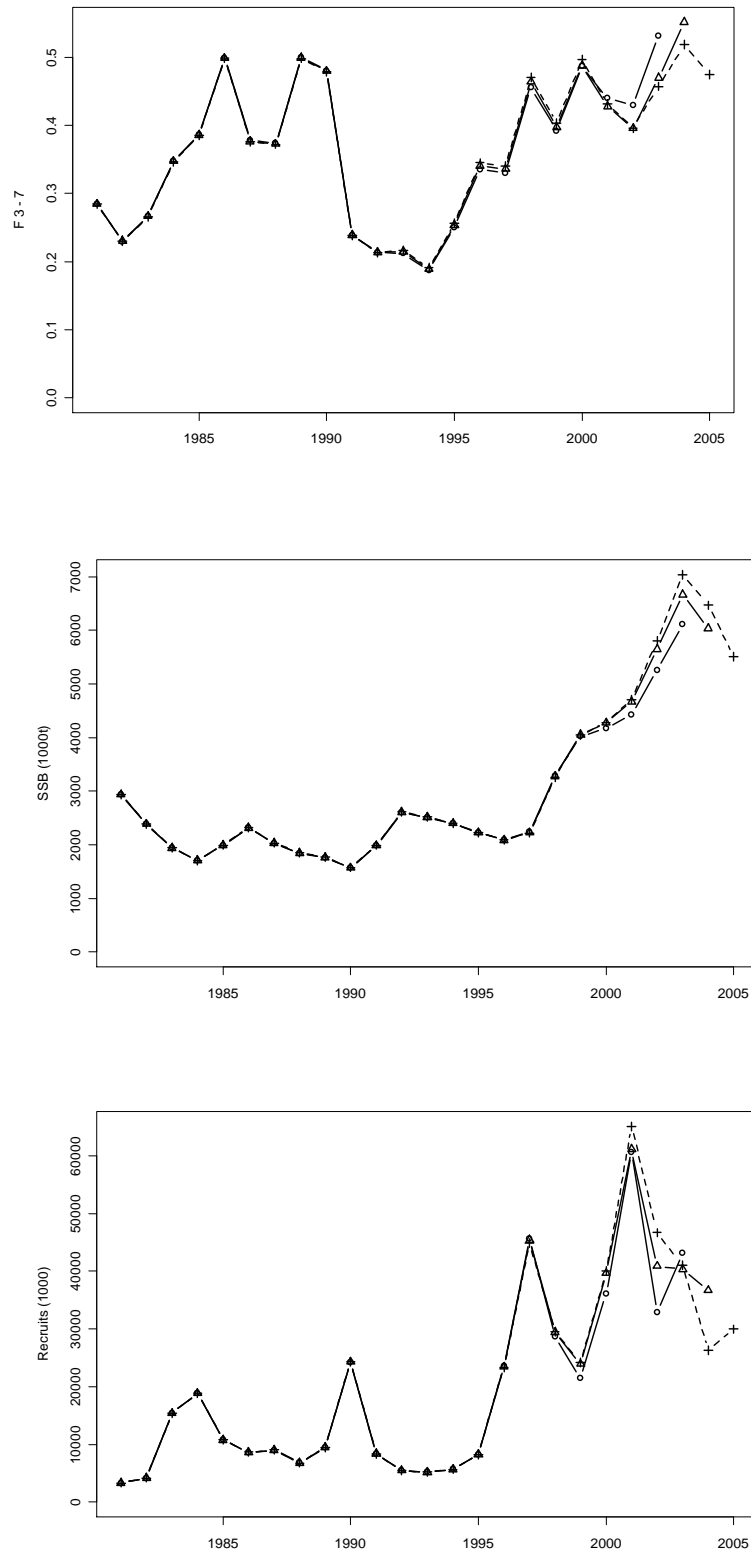

Figure 4.7.5.7 Blue Whiting, SMS exploratory run, Retrospective pattern of F, SSB and recruits.

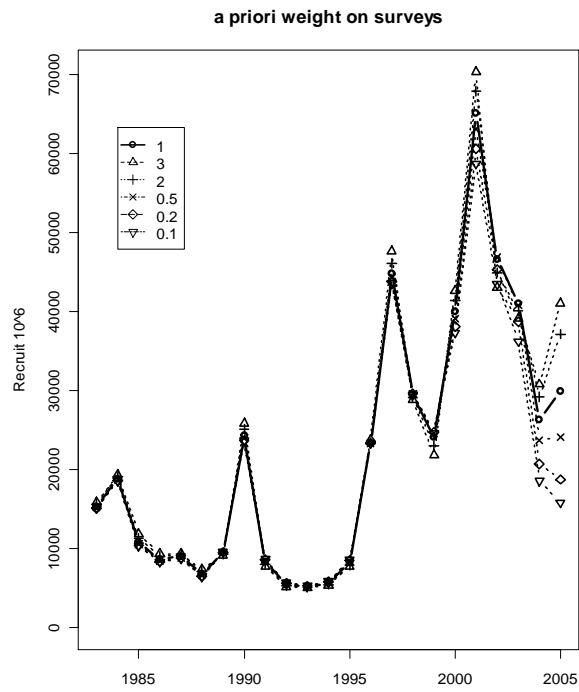
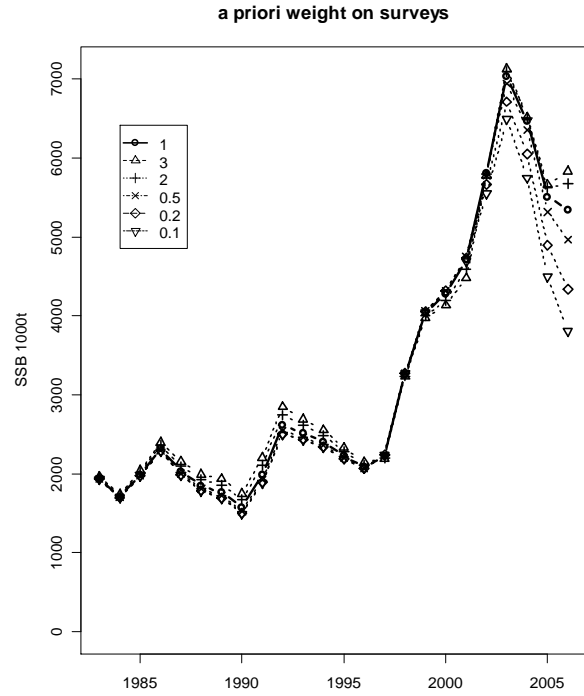

Figure 4.7.5.8 Blue Whiting, SMS exploratory run. Effect on estimated SSB and recruitment of varying a priori weight on survey observations. A priori weight on catch observations is kept constant at 1.0.

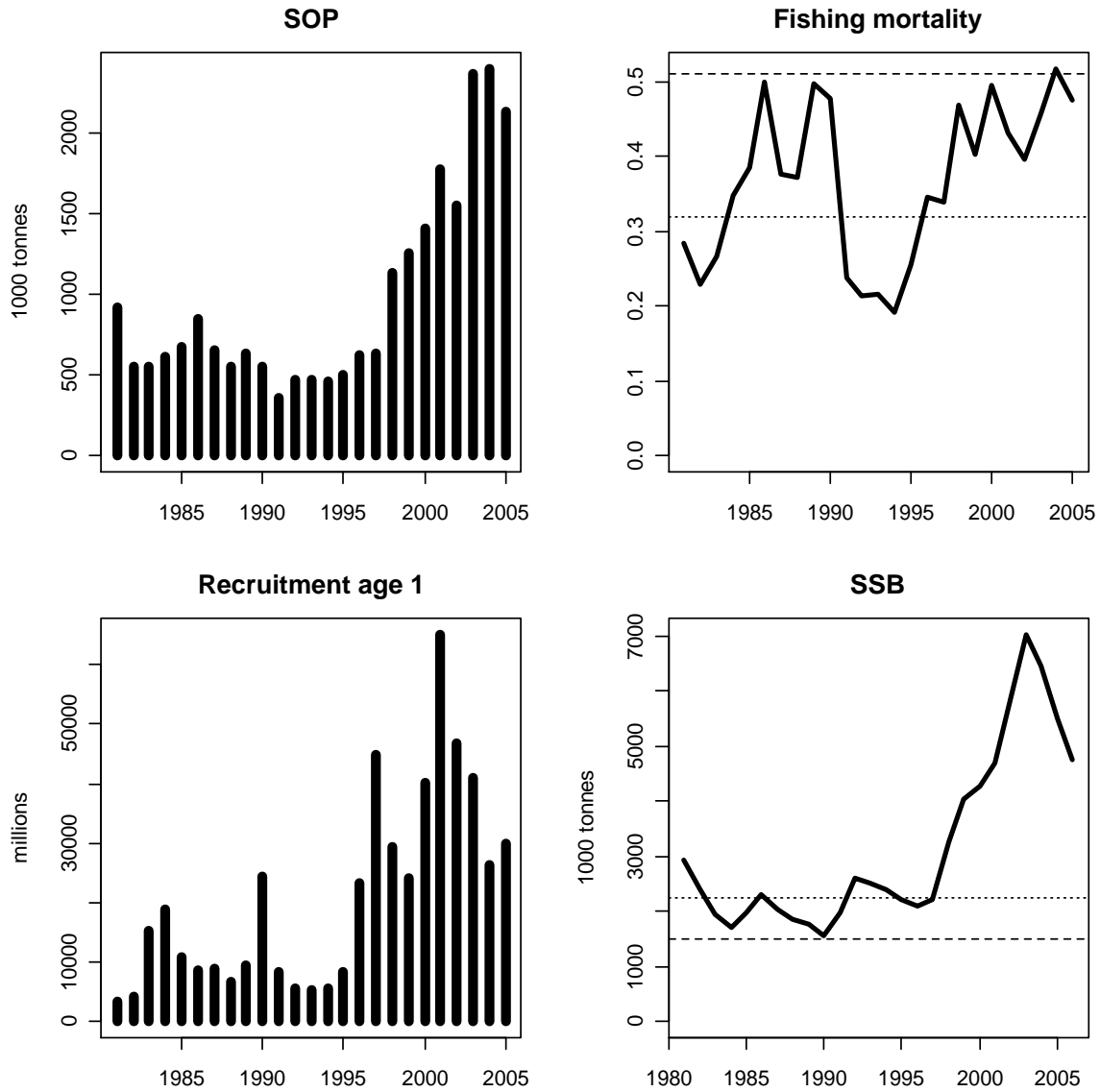

Figure 4.7.5.9 Blue Whiting, SMS. Stock summary, 1981-2005. (SSB in 2006 does not include age 1)

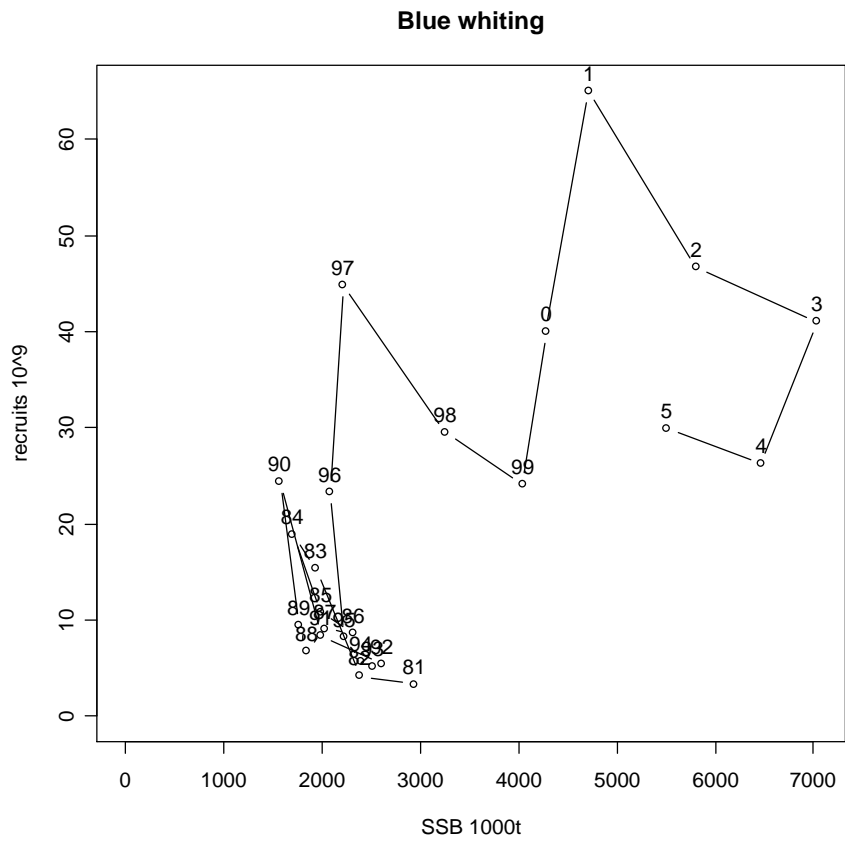

Figure 4.7.5.10 Blue Whiting, SMS. SSB-recruit plot.

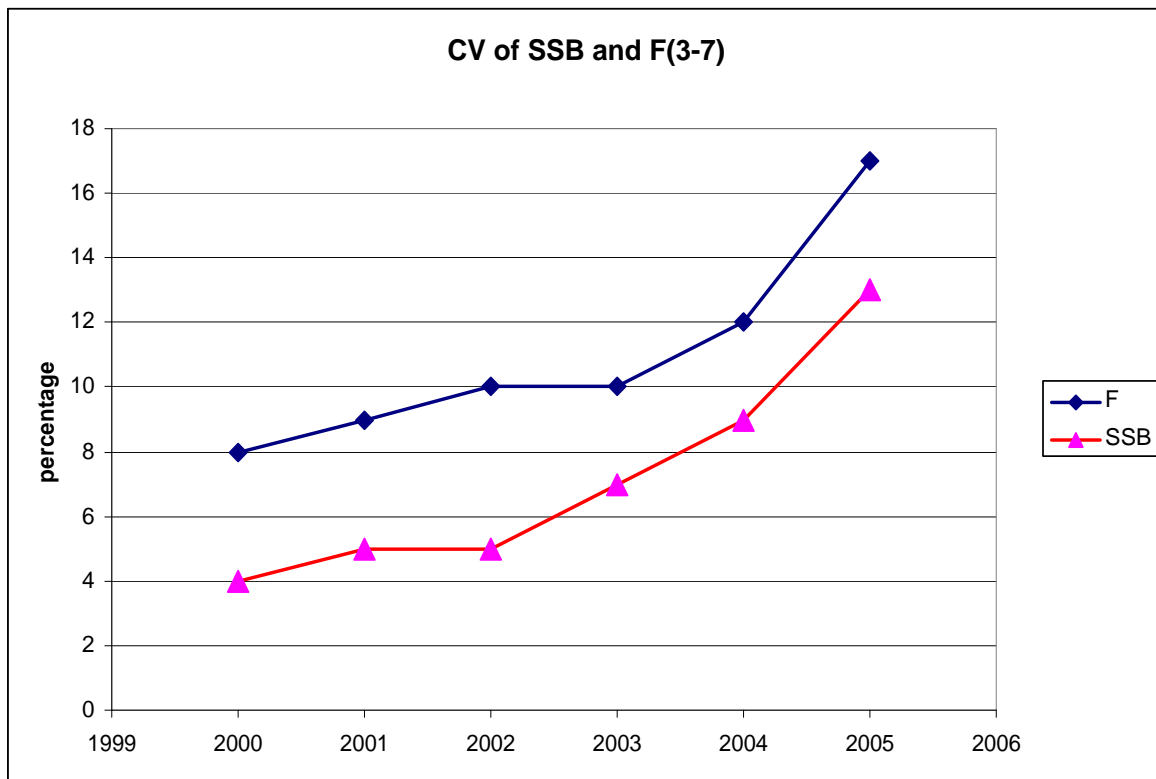
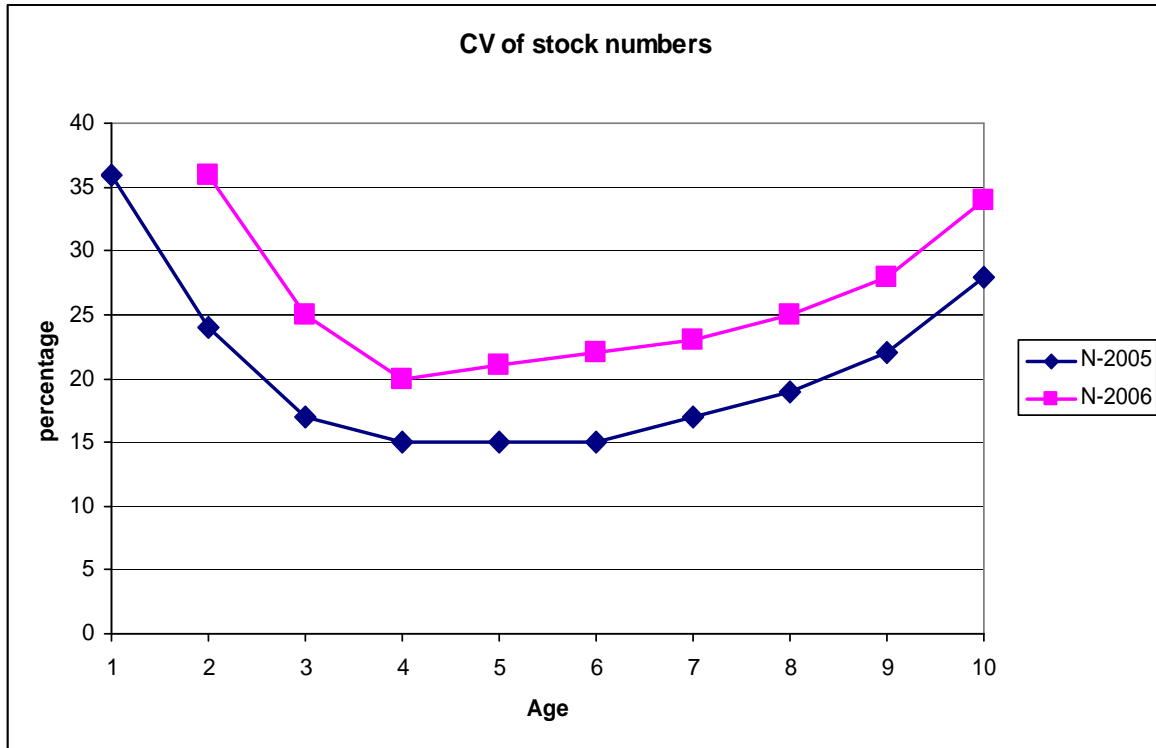

Figure 4.7.5.11 Blue Whiting, SMS. Estimated uncertainties on stock numbers 1 Jan. 2005 and 2006, F and SSB.

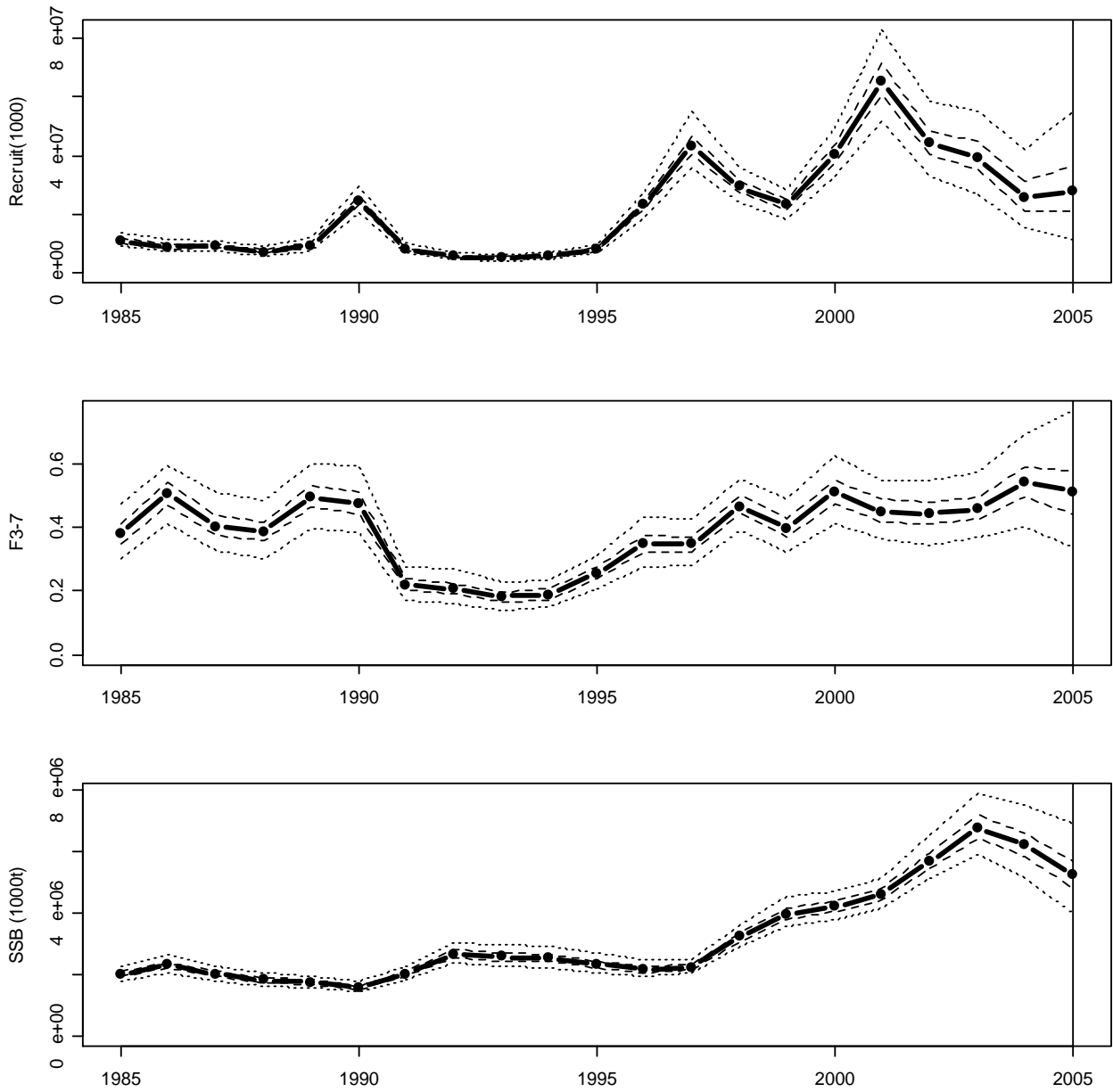

Figure 4.7.5.12 Blue Whiting, SMS. Posterior density (2.5, 25, 50, 75 and 97.5 percentiles) of average F and SSB estimated from 200000 Markov Chain Monte Carlo simulations.

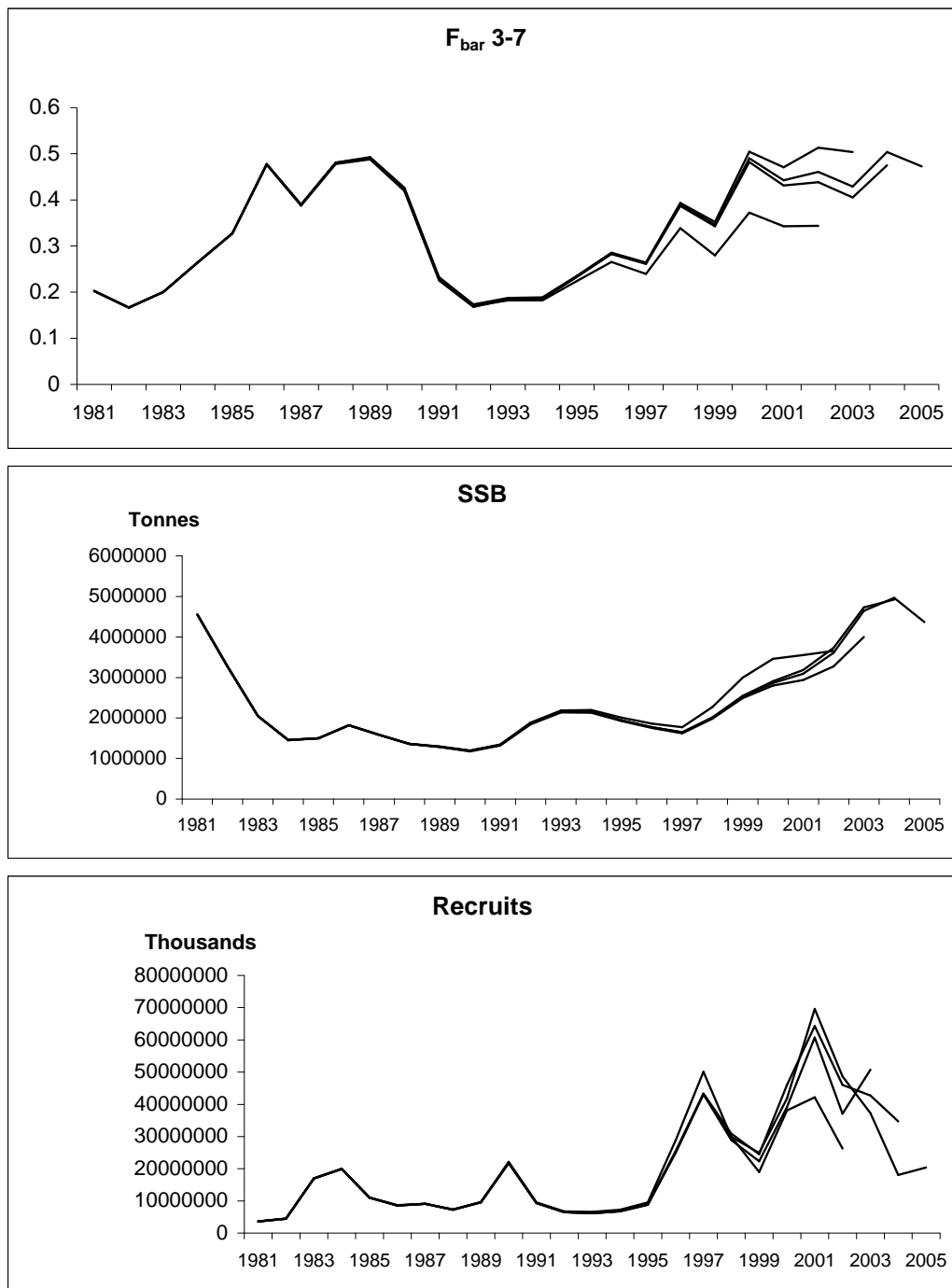

Figure 4.7.6.1. Blue Whiting. XSA results. Retrospective analysis.

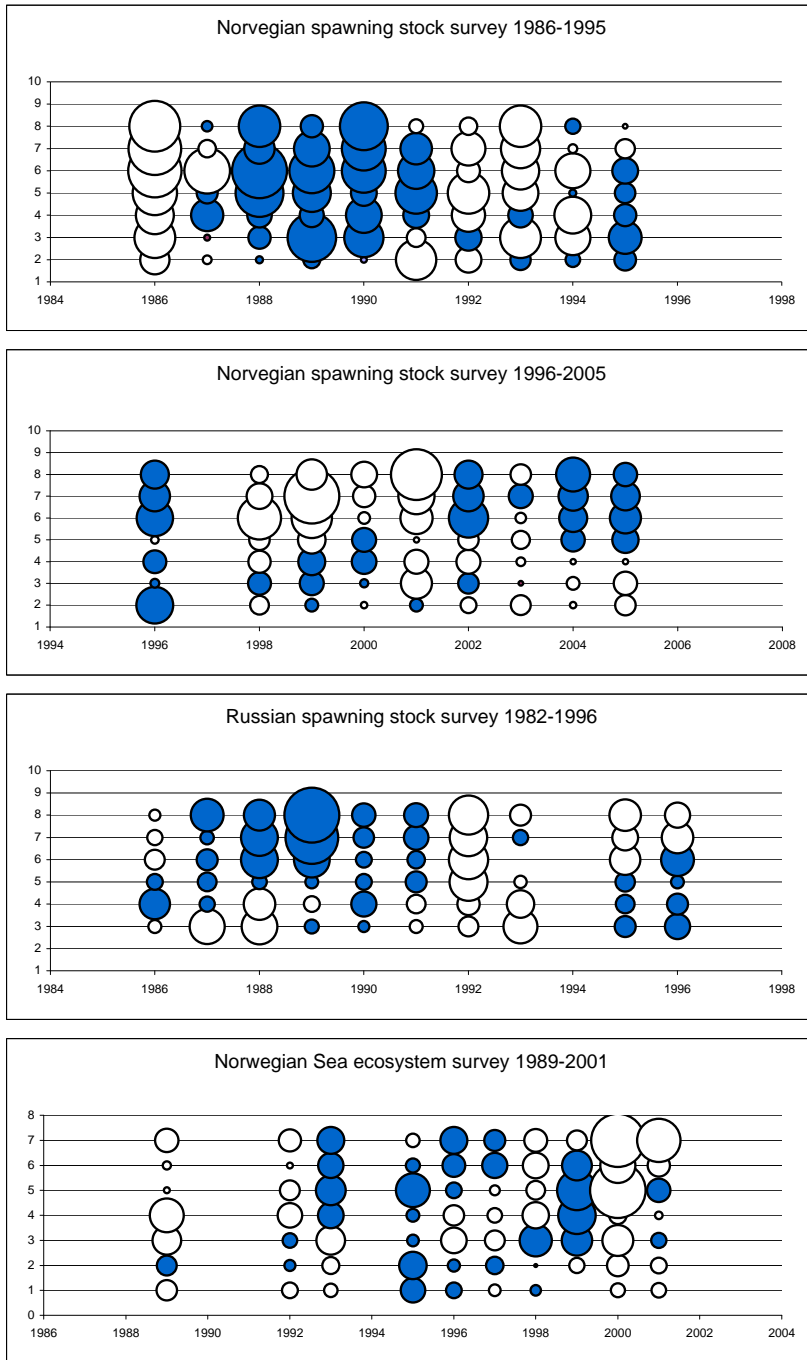

Figure 4.7.6.2. Blue Whiting. XSA log catch residuals at final exploratory run.

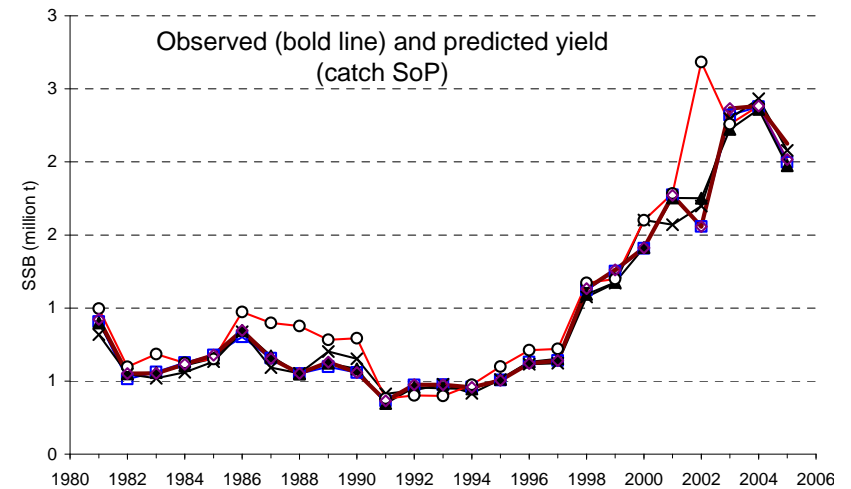
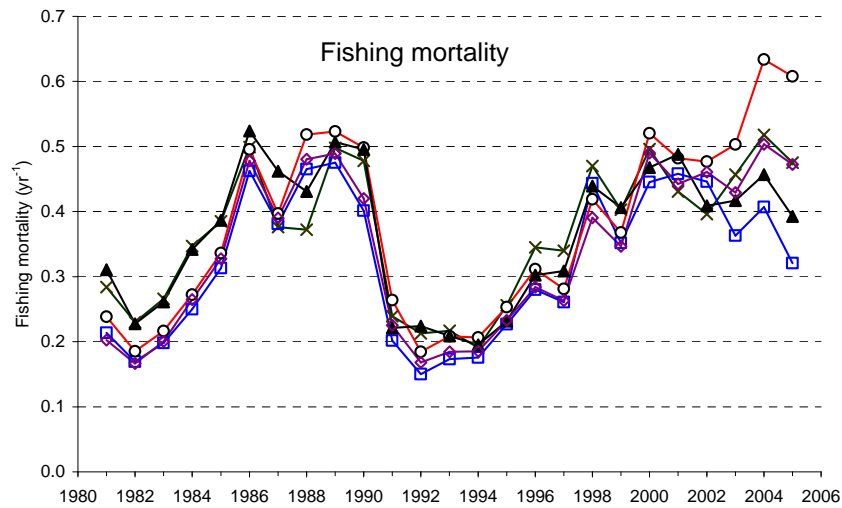
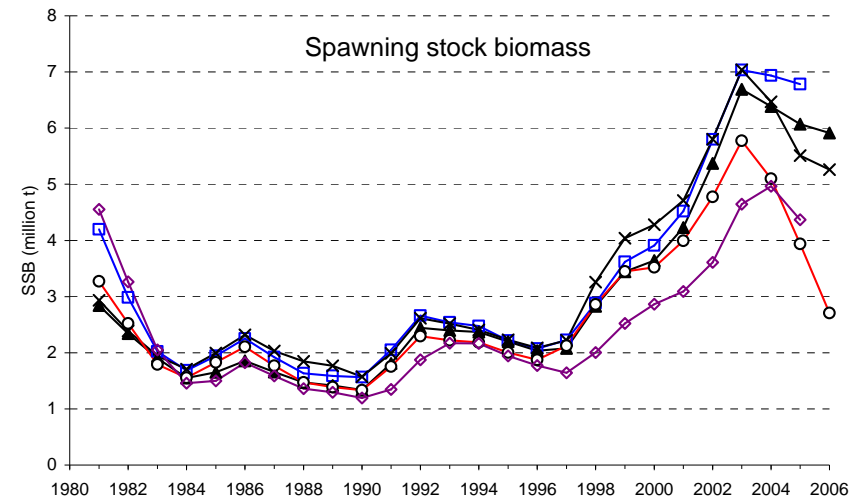
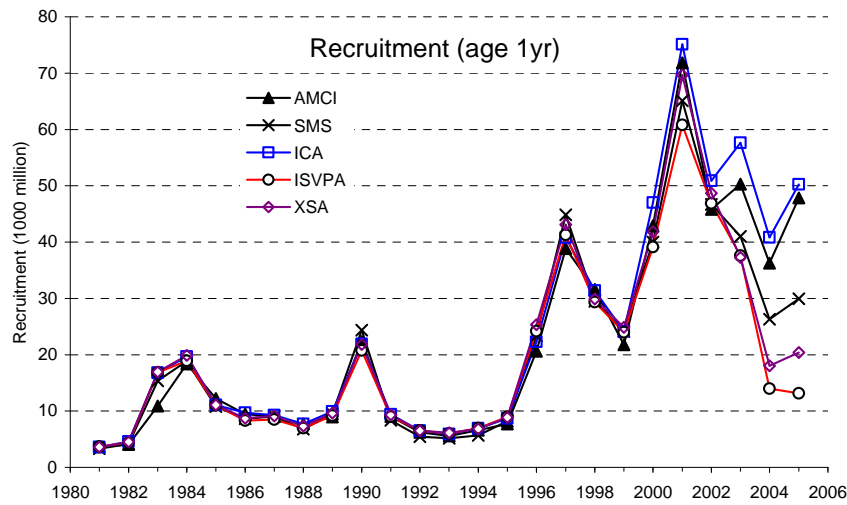

Figure 4.7.7.1. Blue Whiting: Comparisons between final AMCI, ISVPA, ICA, XSA and SMS assessments.

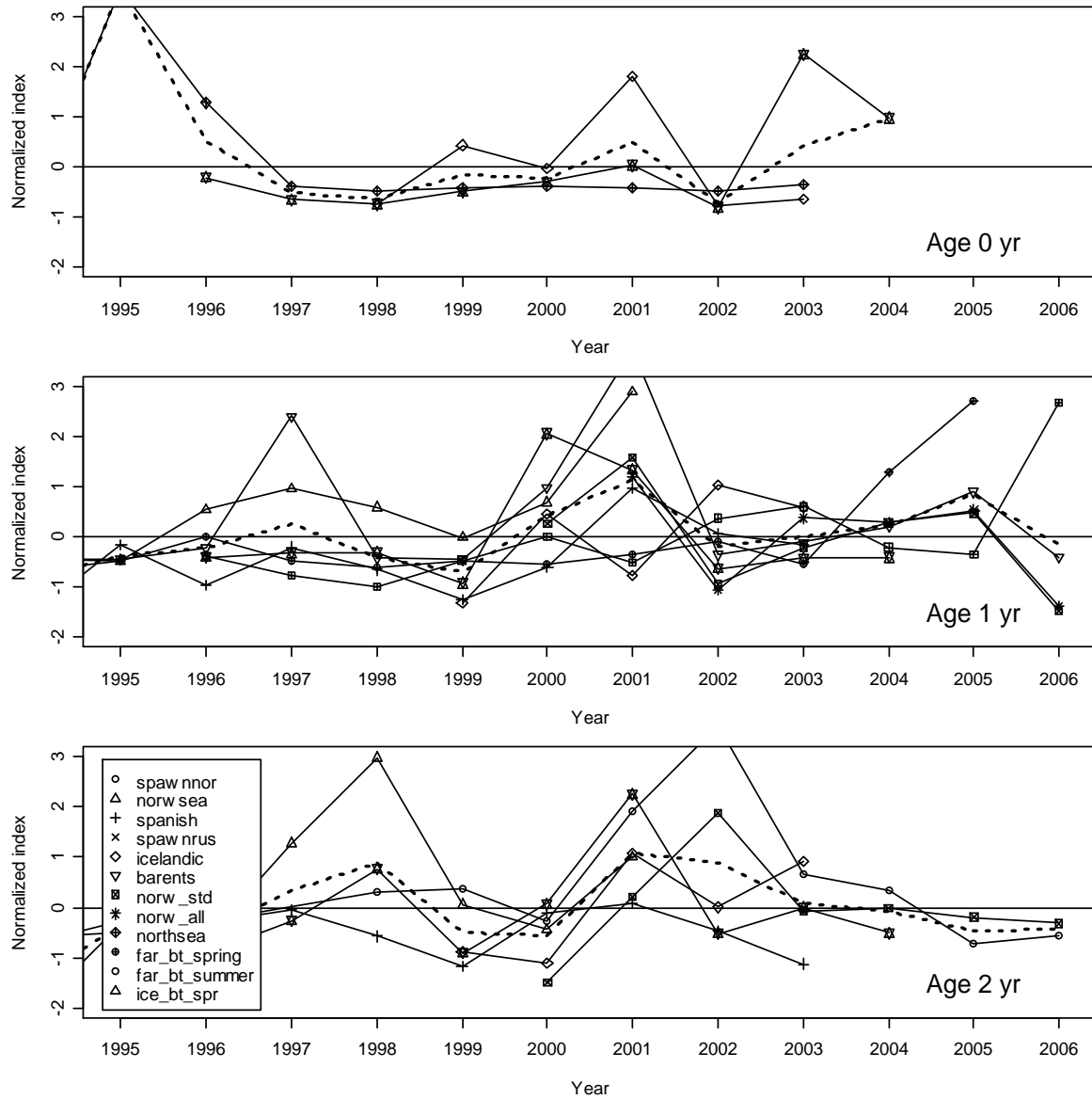

Figure 4.8.1. Overview of survey indices for young blue whiting (Icelandic July acoustic, Barents Sea winter bottom trawl, PGNAPES-coordinated Norwegian Sea May (both for the standard and total coverage), Faroese bottom trawl spring and summer, and Icelandic winter bottom trawl surveys). Each time series is normalized to zero mean and unity variance. The dotted line shows arithmetic mean of the data – please note that ignores the unequal areal coverage of the surveys.

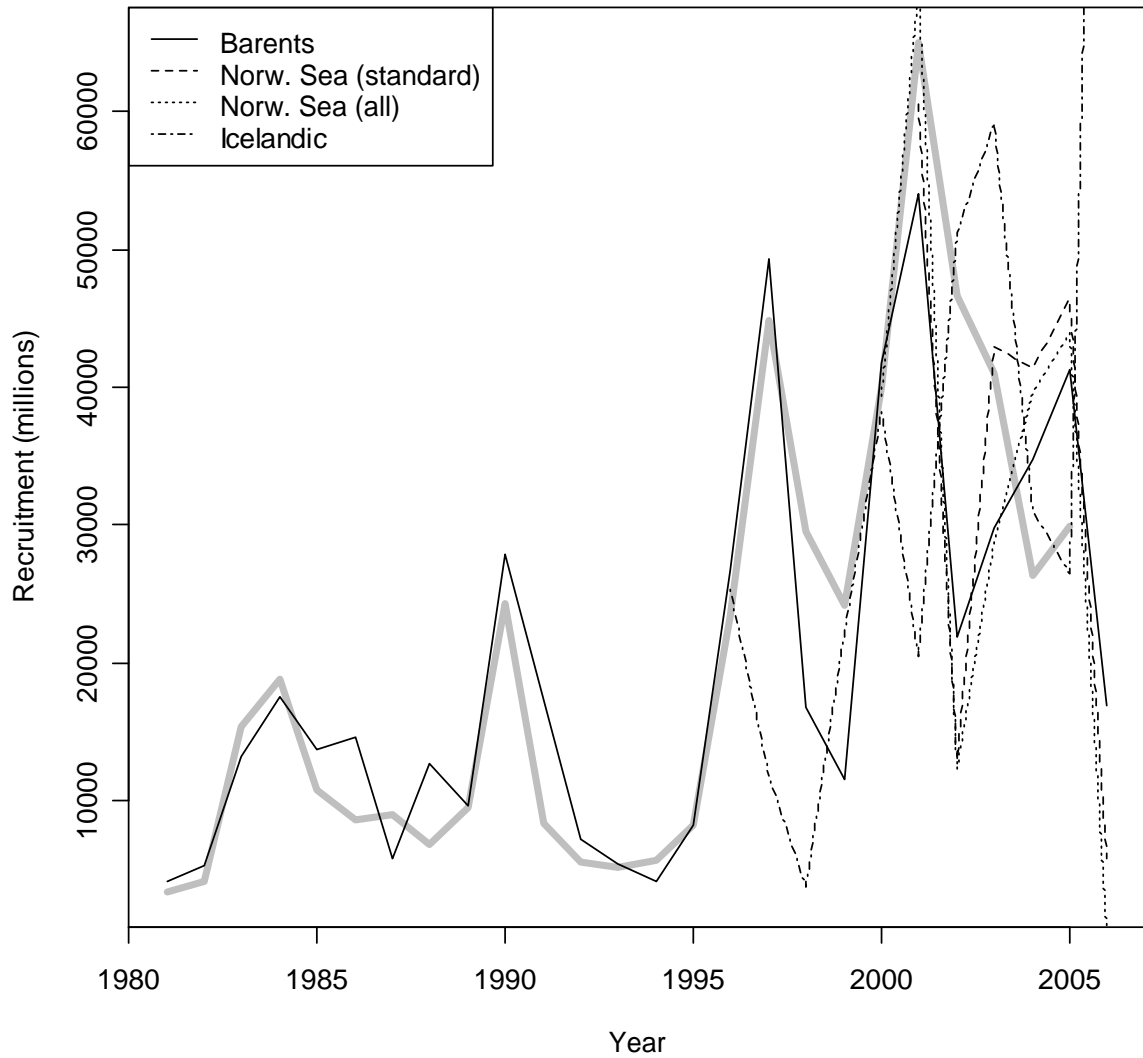

Figure 4.8.2. Blue whiting. Prediction of recruitment from survey data calibrated with the current stock assessment estimate (thick grey curve) for the period 1981–2004. Prediction based on the Barents Sea index is based on log-log regression. Other predictions are based on regressions forced through the origin in natural scale.

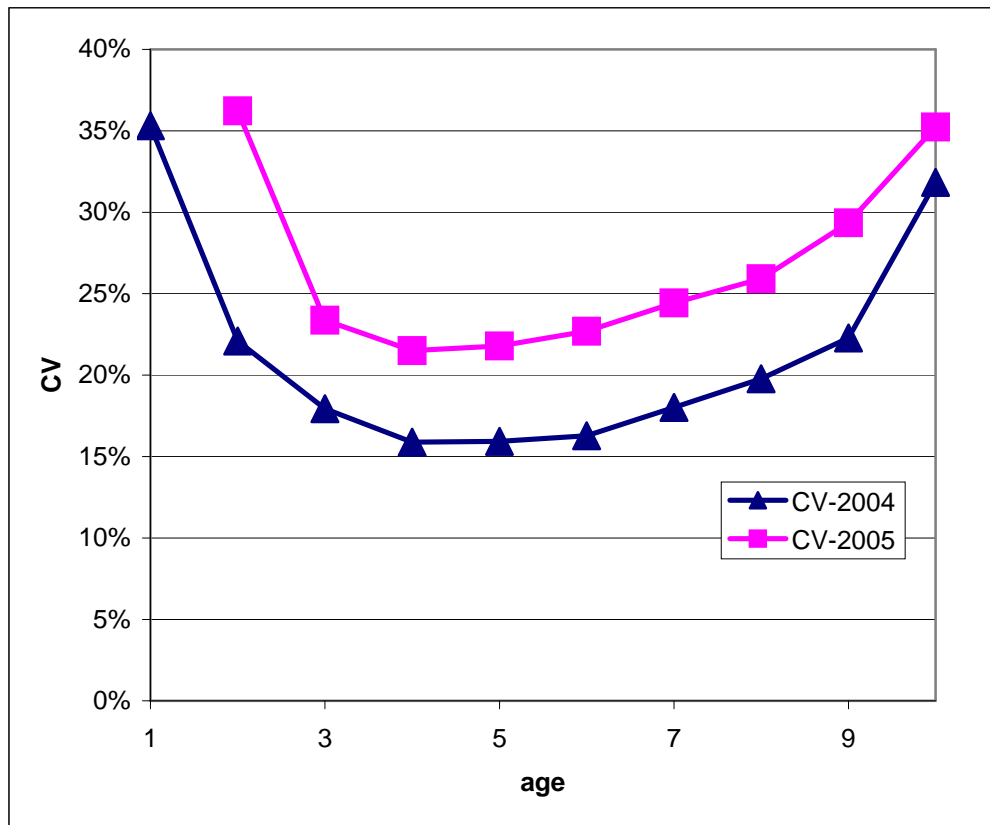

Figure 4.13.1.1 BW. Coefficient of variation of stock numbers at age 1, Jan in the last assessment year (label CV-2004) and in 1.Jan the year after (label CV-2005)

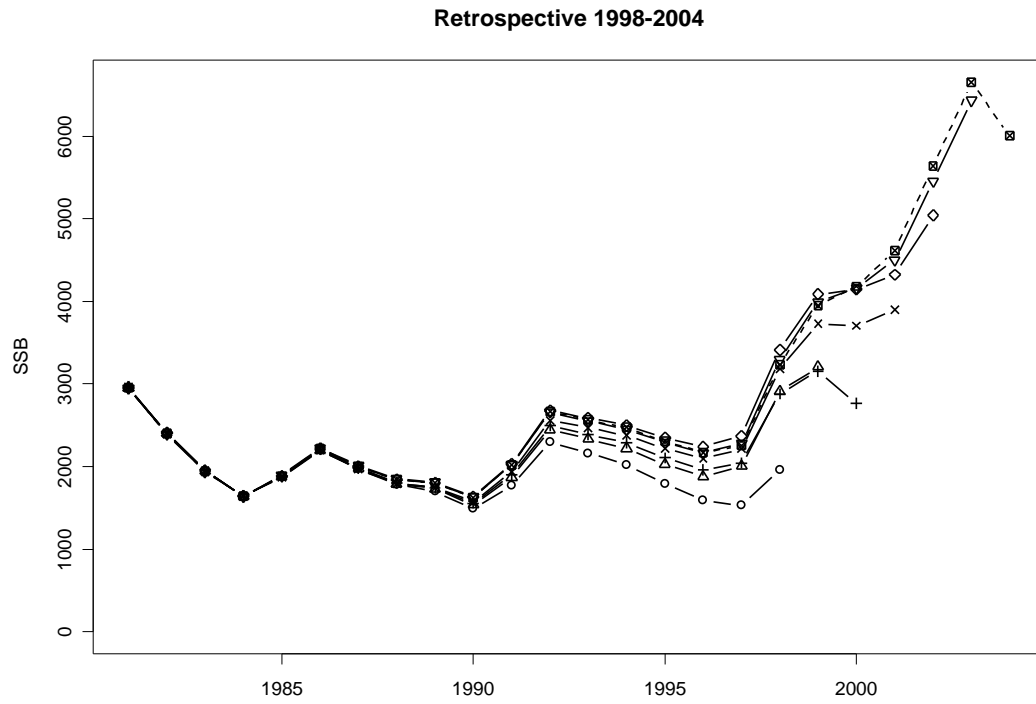

Figure 4.13.1.2 BW. Retrospective pattern for SSB estimated by SMS (ICES 2006/ACFM:05).

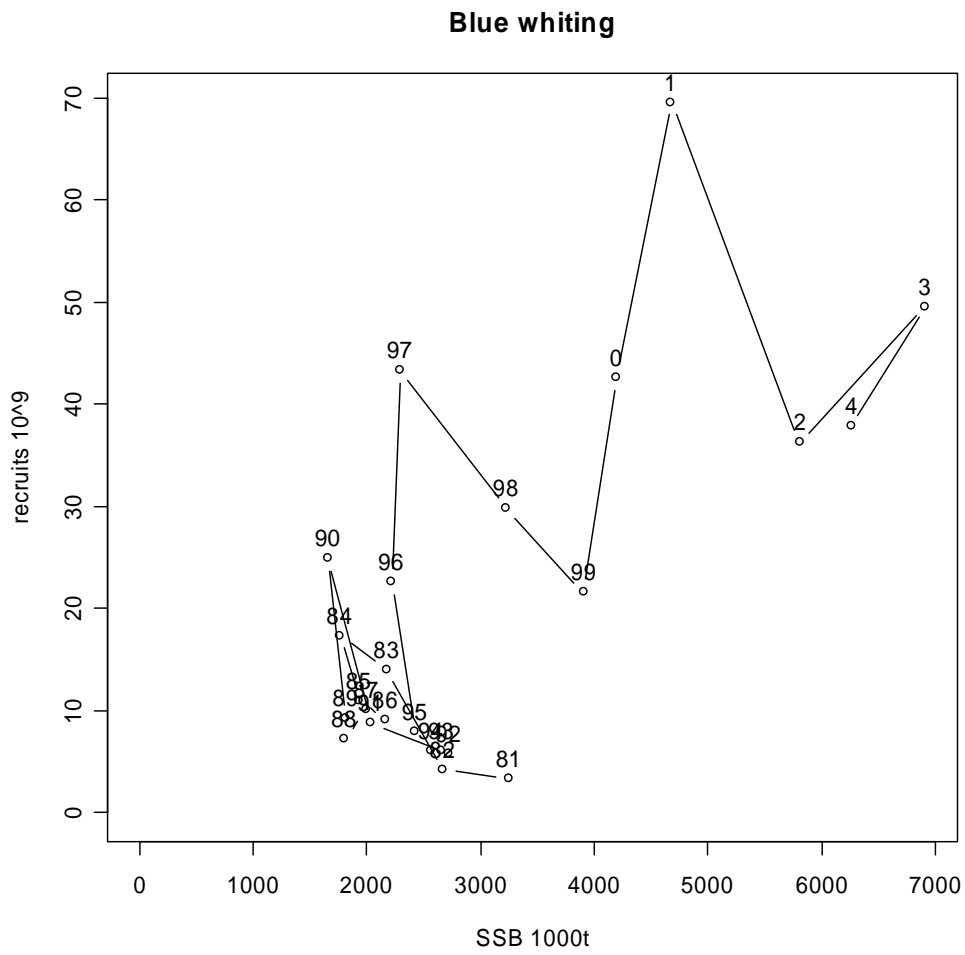

Figure 4.13.1.3 BW. Stock recruitment plot using data from SMS assessment 2005 ((ICES CM 2006 /ACFM:05).

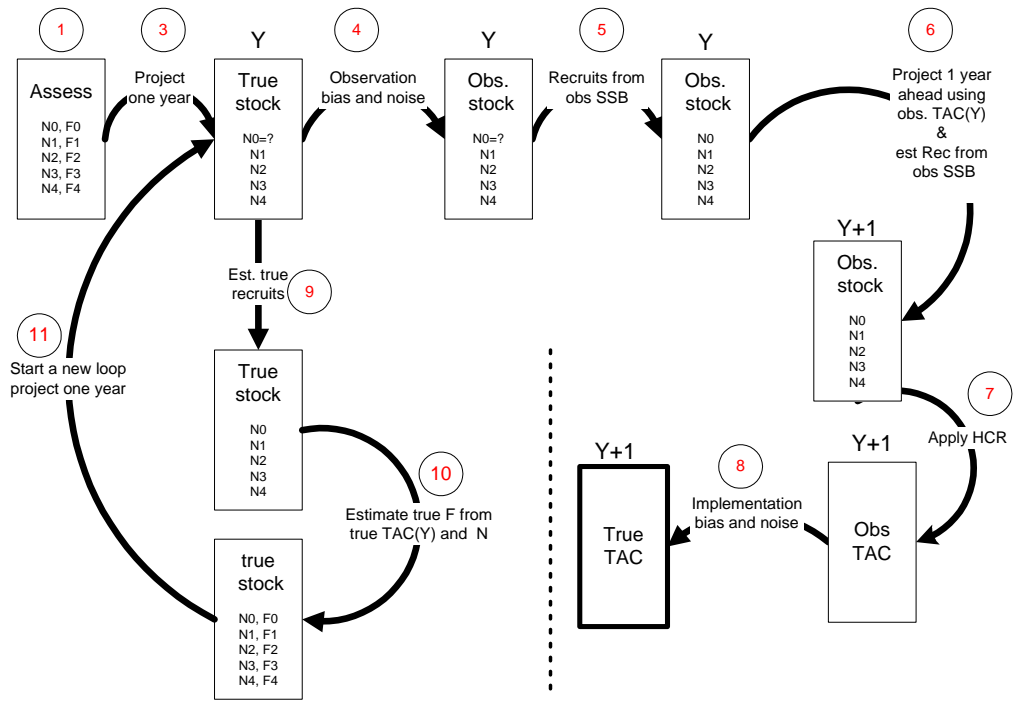

Figure 4.13.1.4. Overview of data manipulations done blue-whiting SMS-HCR.. Numbers in circles refer to annotated text above.

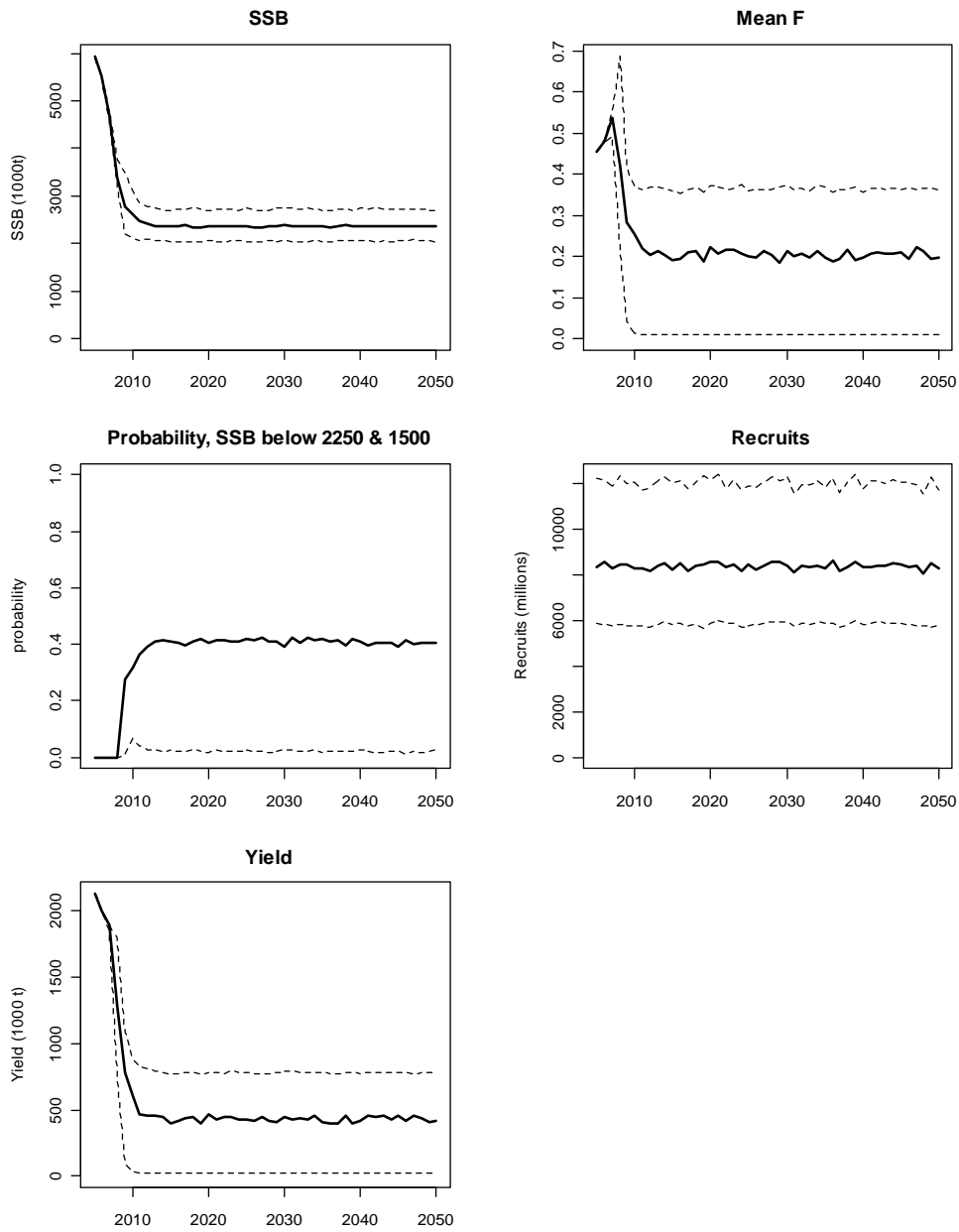

Figure 4.13.1.5. BW. Time series for scenario 1. Low recruitment level. Stock numbers “observed” with 25% CV. The graphs show the median value and the 5th and 75th percentiles, except for the probability plot of SSB being below 1500000 (Blim) and 2250000 (Bpa).

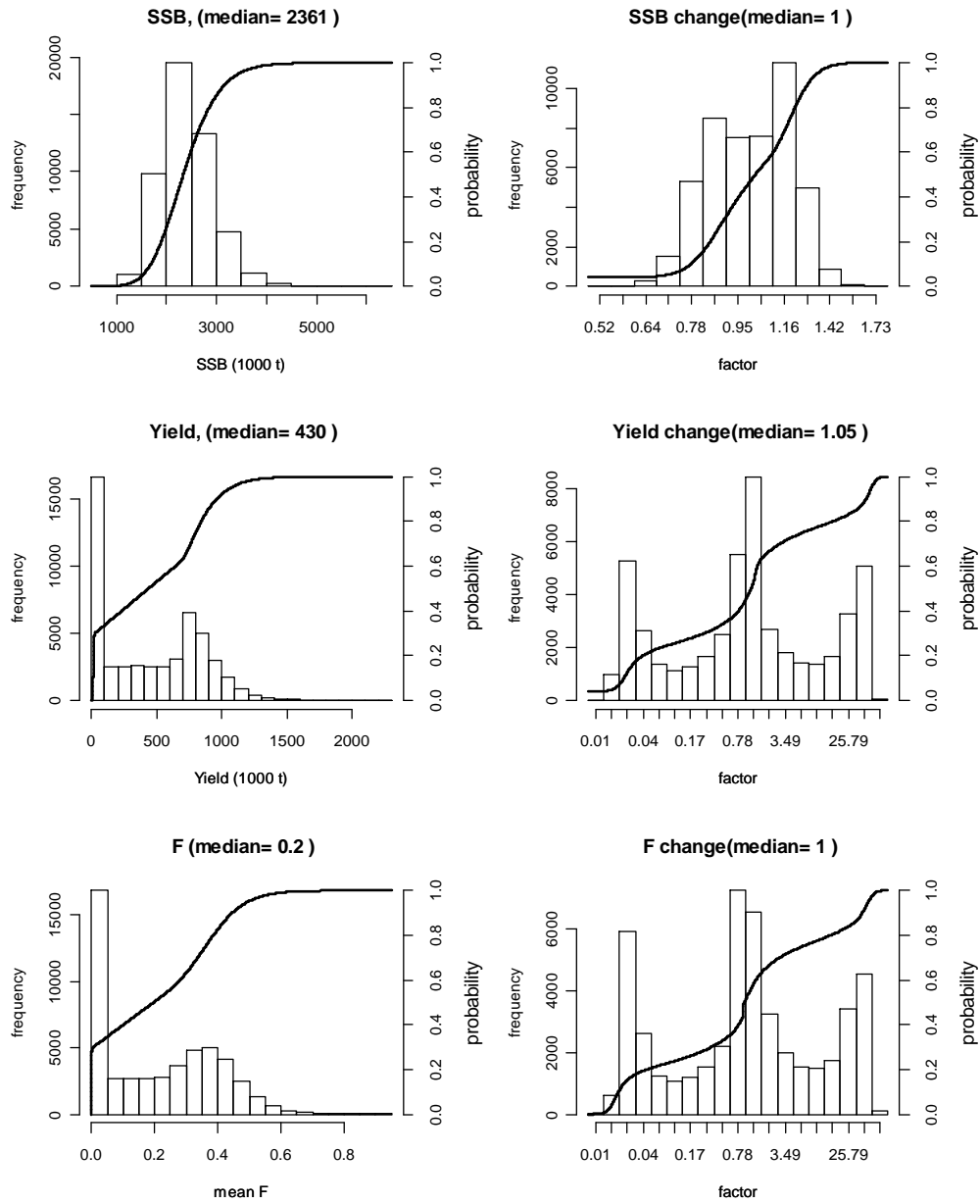

Figure 4.13.1.6. BW. Equilibrium for scenario 1. Low recruitment level. Stock numbers “observed” with 25% CV. Distribution at equilibrium for SSB, Yield and mean F, and year to year change in the same variables.

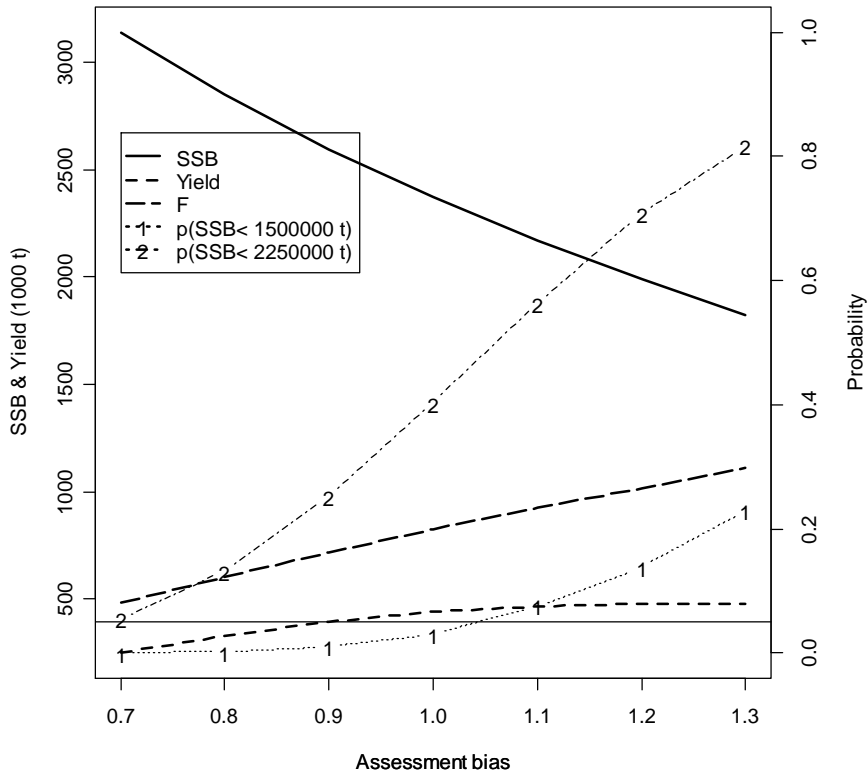

Figure 4.13.1.7. BW. Equilibrium for scenario 2. Stock numbers “observed” with 25% CV and a varying assessment bias factor shown on the X-axis. The graph shows absolute values of mean F, Yield and SSB, and the probability of SSB below Blim and Bpa. Horizontal line gives 5% probability.

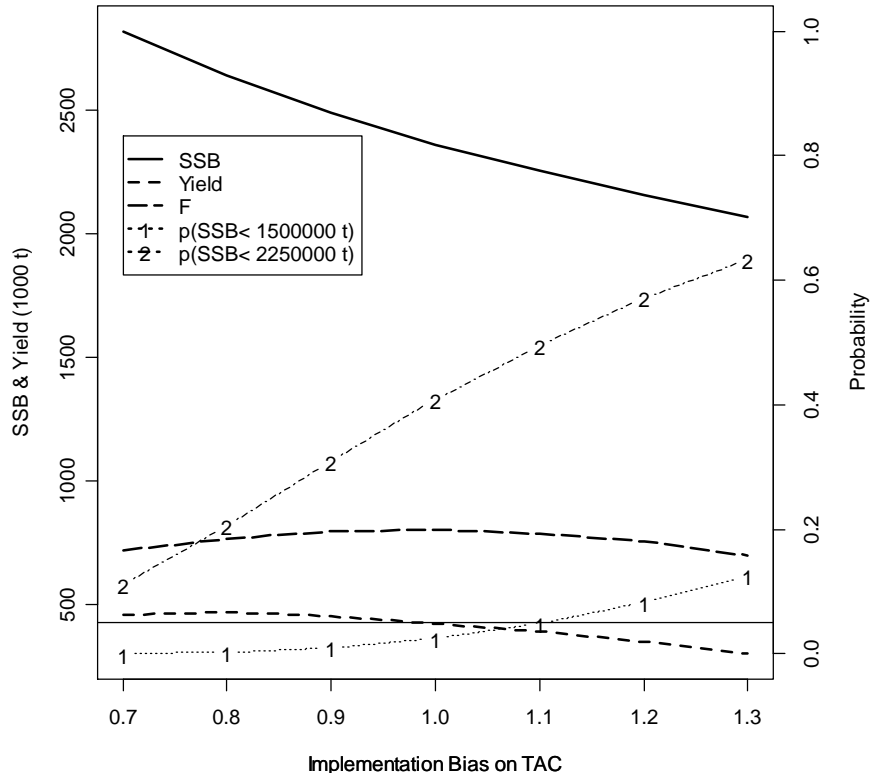

Figure 4.13.1.8. BW. Equilibrium for scenario 3. Low recruitment level. Stock numbers “observed” with 25% CV, 10% CV used as implementation noise and a varying implementation bias factor shown on the X-axis. The graph shows absolute values of mean F, Yield and SSB, and the probability of SSB below Blim and Bpa. Horizontal line gives 5% probability.

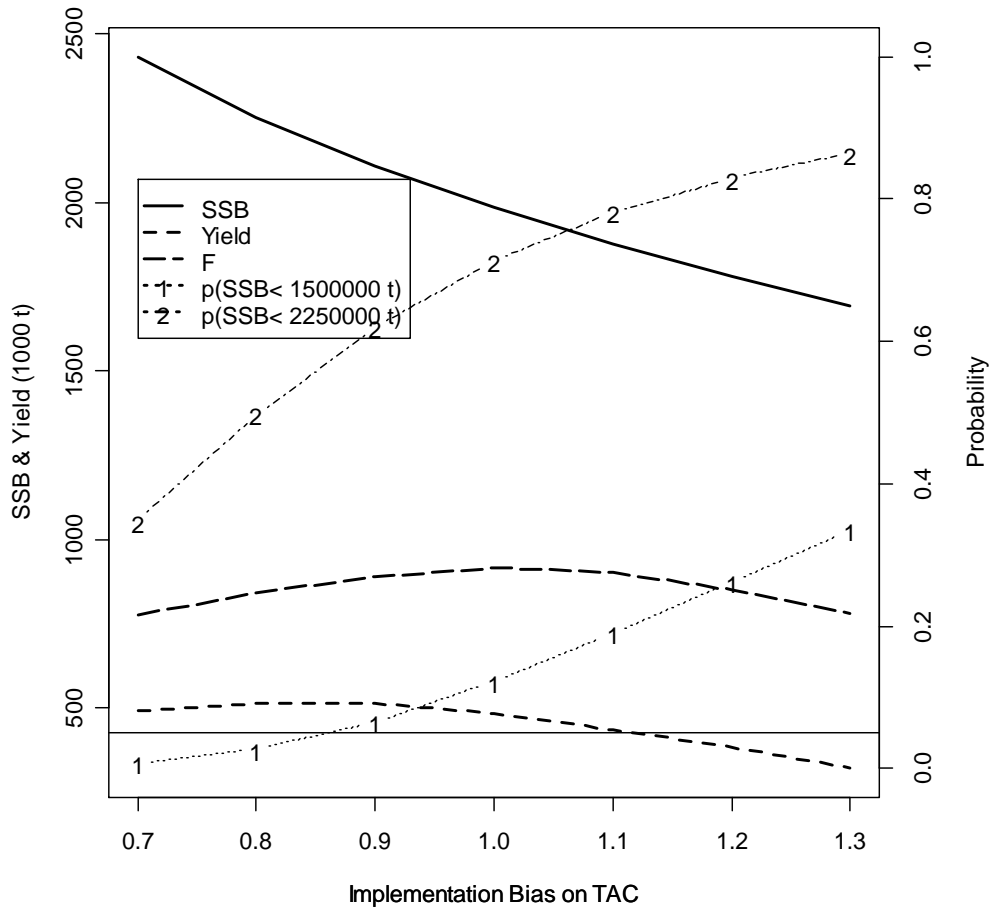

Figure 4.13.1.9. BW. Equilibrium for scenario 4. Low recruitment level. Stock numbers “observed” with 25% CV and a bias factor of 1.20,, 10% CV used as implementation noise and a varying implementation bias factor shown on the X-axis. The graph shows absolute values of mean F, Yield and SSB, and the probability of SSB below Blim and Bpa. Horizontal line gives 5% probability.

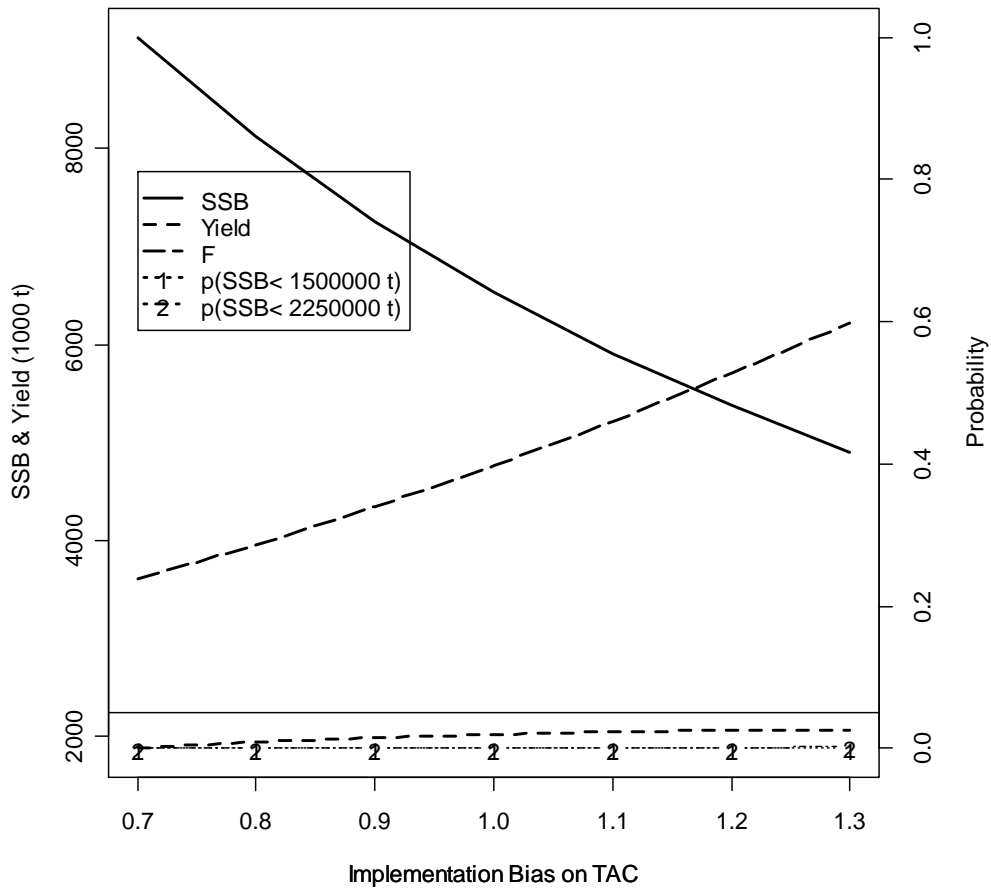

Figure 4.13.1.10. BW. Equilibrium for scenario 5. **HIGH recruitment level**. Stock numbers “observed” with 25% CV and a bias factor of 1.20, 10% CV used as implementation noise and a varying implementation bias factor shown on the X-axis. The graph shows absolute values of mean F, Yield and SSB, and the probability of SSB below Blim and Bpa. Horizontal line gives 5% probability.

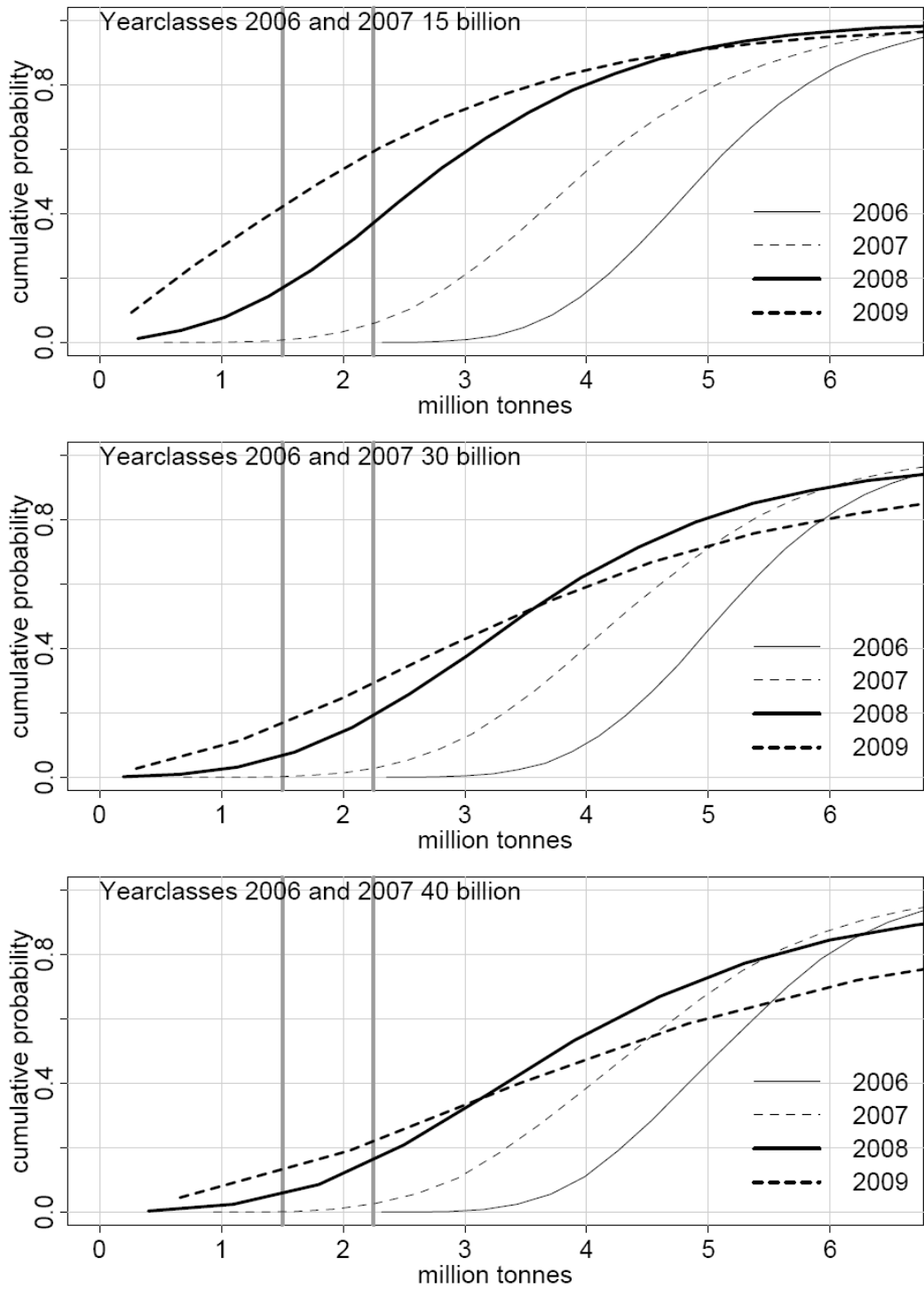

Figure 4.13.2.1. BW. Cumulative probability distribution of spawning stock in 2006 – 2009 for 3 recruitment scenarios.

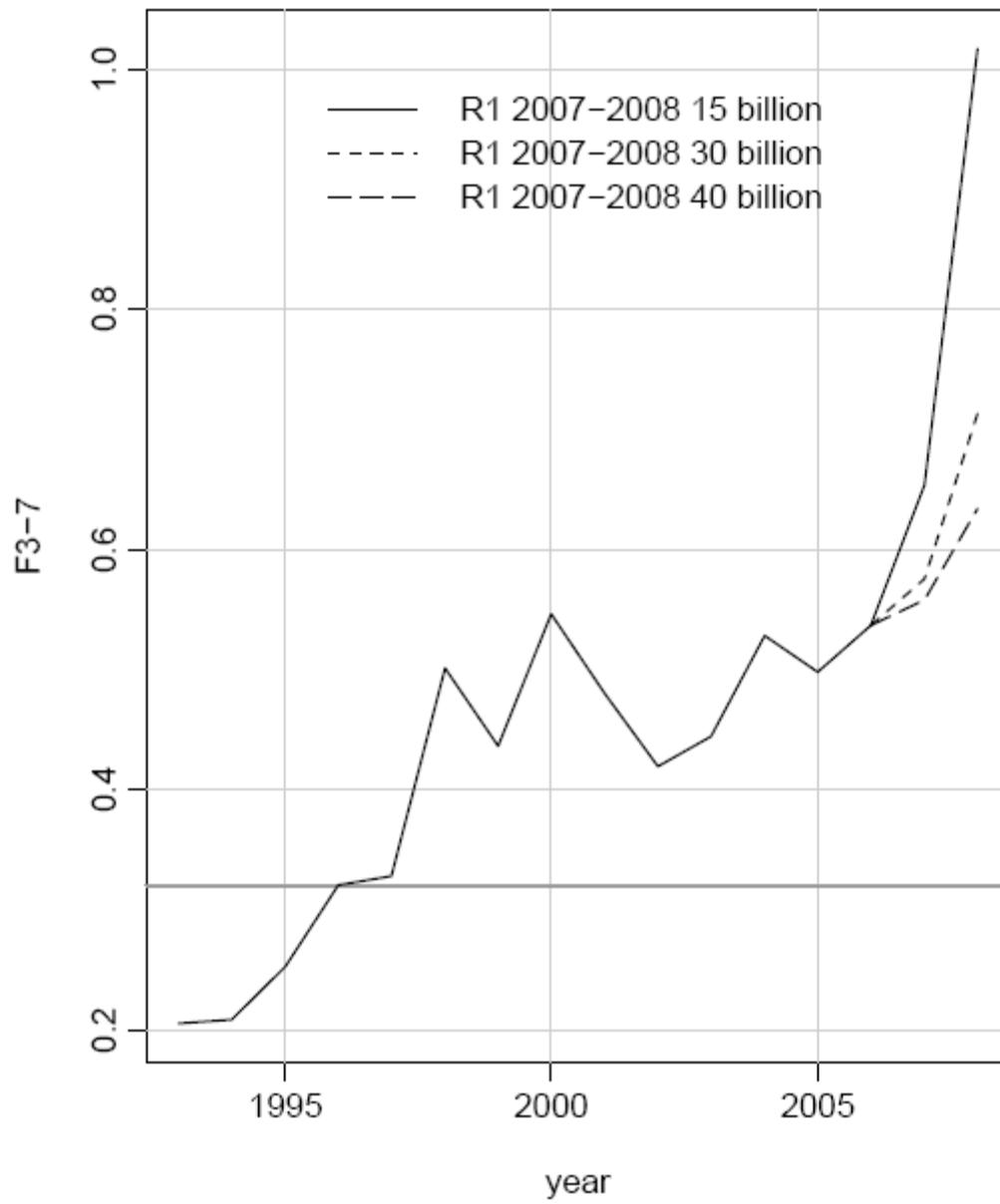

Figure 4.13.2.2. BW. Estimated fishing mortality for the 3 recruitment scenarios.

5 Capelin in the Iceland-East Greenland-Jan Mayen area

5.1 The Fishery

5.1.1 Regulation of the fishery

The fishery is based on maturing capelin, i.e. that part of each year class which spawns at age 3 as well as those fish at age 4, that did not mature and spawn at age 3. The abundance of the immature component is difficult to assess before their recruitment to the adult stock at ages 2 and 3. This is especially true of the age 3 immatures.

The fishery of the Icelandic capelin has, therefore, been regulated by preliminary catch quotas set prior to each fishing season (July–March). Predictions of TACs have been computed from autumn survey data the year before on the abundance of 1 and 2 year old capelin. The process includes historical relationships between such data and the back-calculated abundance of the same year classes, growth rate and stock in numbers, natural mortality and the provision of a remaining spawning stock biomass of 400 000 t. Final catch quotas for each season have then been set according to the results of acoustic surveys of the maturing, fishable stock, carried out in autumn (October–November) and/or winter (January/February) in that fishing season. A detailed description and test of this method for the period 1979-2001 was given by Gudmundsdottir and Vilhjálmsson, 2002. A summary of the results of this catch regulation procedure is given in Table 5.1.1.

However, since 2001 the juvenile distribution areas have changed and it has not proven possible to locate them but in part. The above catch procedure could therefore not be used. This has been tackled by setting very low, and sometimes no, summer/autumn TACs and the fishery not been opened until a ‘reliable’ fishable stock assessment has been obtained, usually in January of the season.

Over the years the fishery has been closed during April - late June and the season has started in July/August or later, depending on the state of the stock. Due to very low stock abundance there was a fishing ban lasting from December 1981 to November 1983. There was also a ban on capelin fishing during the summer/autumn seasons in 2005 and 2006 due to lack of information on the state of the stock. In addition, areas with high abundances of juvenile age 1 and 2 capelin (in the shelf region off NW-, N- and NE-Iceland) have usually been closed to the summer and autumn fishery.

5.1.2 The fishery in the 2005/2006 season

Because of a total lack of information on the state of the stock, ACFM recommended that fishery should not be opened until assessment surveys had verified that a catch could be allowed with the usual prerequisite of a remaining spawning stock of 400 000 t after taking account of natural mortality. This advice was accepted by all parties concerned.

All attempts to locate and assess the fishable stock in summer and autumn 2005 failed, i.a. because of extensive drift ice between Iceland and Greenland and north of Iceland, west of the Kolbeinsey Ridge. The only catches taken were about 9 000 t off NE-Iceland in late December by scouting vessels which had been commissioned to help locate the stock. (Table 5.2.1).

In the first half January 2006 the research ship and a large fleet of scouting vessels only found

scattered concentrations of capelin northeast of Iceland. In view of this the fishing ban was not lifted.

During the last week of January when another assessment survey was carried out east of Iceland it became obvious that capelin had gradually been arriving in this area from the north, which resulted in a total estimate of 615 000 t of mature fish. This corresponded to a TAC of 215 000 t, which was subsequently set. At the time of the survey about 24 000 t had been caught by the search fleet (about 9 000 t in December 2005 and 14 000 t in January 2006), raising the total TAC for the 2005/2006 season to about 238 000 t (Table 5.1.1).

Like in winter 2005, the first spawning run was late in entering the warm Atlantic water off the southeast coast. From there, the capelin migrated slowly westward in near-shore areas and most of the spawning took place off the south and southeast coasts. As usual, catch rates were high in the shallow water area and huge schools of capelin were reported in the southern Faxaflói. These reports were checked by a research vessel and several fishers but proved unfounded.

No spawning migrations were located arriving from the northwest, but there were frequent reports of scattered spawners from various locations off the north and east coasts. These were not fished and the remaining spawning stock must therefore have been somewhat in excess of the targeted 400 000 t.

The total catch during the 2006 winter season was 238 000 t (Table 5.2.1). A large proportion was processed for human consumption.

5.2 Catch Statistics

The total annual catch of capelin in the Iceland-East Greenland-Jan Mayen area since 1964 is given by weight, season, and fleet in Table 5.2.1.

The total catch in numbers during the summer/autumn 1984–2005 and winter 1985–2006 seasons is given by age and years in Tables 5.2.2 and 5.2.3.

The distribution of the catch during the summer-autumn 2005 and winter 2006 seasons is given by length groups at age in Tables 5.2.4 and 5.2.5.

5.3 Surveys

5.3.1 0-group and 1-group surveys in August

The distribution and abundance of 0-group capelin in the Iceland-East Greenland-Jan Mayen area has not been recorded during surveys carried out in August since 2003. The same is true for age 1 capelin which was recorded during the 0-group surveys (Tables 5.3.1.1 and 5.3.1.2).

5.3.2 Abundance of immature age 1 and 2 capelin in autumn 2005 and 2006

Once again, the November 2005 survey failed to locate but a few immatures, both north and northeast Iceland and in the Denmark Strait. Drift ice prevented any search over the Greenland plateau west of there.

There was so much drift ice in the most likely juvenile area between NW-Iceland and Greenland as well as over the Greenland shelf west of the Denmark Strait that no attempt was made to survey the area in spring and early summer 2006.

In July 2006 there began a multidisciplinary project (oceanography/ecology) covering the area from Ammassalik in the west to about 10°W east of Iceland as well as the Iceland Sea north to

71°N. One of the main purpose of this project is to study the distribution, behaviour and feeding habits of all age groups of capelin in spring and summer. With regard to capelin, this first survey was not totally successful since ice still covered large parts of the area next to Greenland, in places quite wide.

Naturally, the results of this survey have not been analyzed in full, but although all age groups of capelin were encountered their abundance was low although occurring in fairly wide parts of the survey area.

5.3.3 The adult fishable stock

In spring 2005 there was much drift ice in the area between Iceland and Greenland and to Scoresby Sound in the north reaching east to the Kolbeinsey Ridge. In late June-early July the ice seemed to be retreating and an attempt was made by a research vessel with the assistance of 4 scouts to survey the area. However, ice conditions quickly deteriorated again and no progress could be made.

In November five fishing vessels were engaged to search the area between about 14°W and the east coast of Greenland, the Denmark Strait and the plateau west of there and from the north Icelandic shelf to 71°N. Weather was good and the operation went well – except for the important fact that very few capelin were located. There was drift ice in a relatively wide area off most of the East-Greenland coast and over the Greenland shelf west of the Denmark Strait. The research vessel recorded only 15-20 000 t of capelin, the lowest abundance recorded in a November survey.

Another survey was carried out in December 2005 by a research vessel and four scouts. The main emphasis was on the area near the shelf edge north and northeast of Iceland where the earlier scouting vessels had caught some capelin. capelin were seen in a fairly wide area from the Kolbeinsey ridge eastwards to east of Langanes. However, the fish were very scattered and the total estimate fell far short of that required for opening a general fishery.

The research vessel was tied up in harbour on the east coast and carried out its first survey between 65°N and 66°30'N east of Iceland during 3-6 January. The total estimate came to about 15000 t of large capelin. At the same time 5 fishers searched the area north of there and then west off the north coast to Látragrúnn off the Vestfirðir peninsula, from the shelfbreak north to about 68°30'N off the north coast, but found nothing. Weather conditions were good in this area, but quite stormy east of Iceland.

During 13-16 January the research vessel repeated the earlier survey off the central east coast and then continued to the north and west to north of Melrakkasletta (16°W). Although the weather was much improved as compared to the previous survey and the area considerably larger, the total estimate came only to some 35 000 t of capelin with an average weight of 21.3 g.

A third estimate was carried out during 26 January-2 February. In the beginning a rough pilot survey was run south, beginning at 65°15'N and reaching east to about 09°00'W, where acoustic values were extremely low. The actual assessment began there and the survey was then run northward using information from the pilot survey to determine the length of the E/W transects as well as the distance between them. The distribution of the capelin was relatively even and on the whole well suited for acoustic assessment. By this time much capelin had assembled in the area north of 65°N and the total estimate of mature fish came to 615 000 t.

An age disaggregated abundance by age, length and weight are given in Table 5.3.2.1.

5.4 Historical Stock Abundance

The historical estimates of stock abundance are based on the “best” acoustic estimates of the abundance of maturing capelin in autumn and/or winter surveys, the “best” in each case being defined as that estimate on which the final decision of TAC was based. Taking account of the catch in number and a monthly natural mortality rate of $M = 0.035$ (ICES 1991/Assess:17), abundance estimates of each age group are then projected to the appropriate point in time. Since natural mortality rates of juvenile capelin are not known, their abundance by number has been projected using the same natural mortality rate.

The annual abundance by number and weight at age for mature and immature capelin in the Iceland-East Greenland-Jan Mayen area has been calculated with reference to 1 August and 1 January of the following year for the 1978/79–2005/06 seasons. The results are given in Tables 5.4.1 and 5.4.2 (1 August and 1 January, respectively). Table 5.4.2 also gives the remaining spawning stock by number and biomass in March/April 1979–2003.

The observed annual mean weight at age, obtained from catch and survey data from January, was used to calculate the stock biomass on 1 January. The observed average weight at age of adult capelin in autumn (Table 5.5.1.2) is used to calculate stock biomass of the maturing components in summer. Because there is a small weight increase among mature capelin in February and March, the remaining spawning stock biomass is underestimated.

5.5 Stock Prognoses

5.5.1 Stock prognosis and TAC in the 2006/2007 season

No data for predicting the abundance of the fishable stock in the 2006/2007 season are available as yet and will most likely become available until November 2006 or even January 2007. When ‘reliable’ acoustic stock assessments become available, the results will be projected directly taking account of natural mortality and provide for a remaining spawning stock of 400 000 t as has been done under such circumstances in the last few years. Until then the Working Group recommends that a fishery is not opened

5.5.2 Stock prognosis and assessment for the 2007/2008 season

As described in section 5.3.2.2., all attempts to locate and assess immature age 1 and 2 capelin (age 2 and 3 in 2007) were unsuccessful. In fact, only trace amounts were measured where surveys located any of these capelin at all. Therefore, there are no data available to the Working Group for predicting likely fishable/spawning stock size in the 2007/2008 season.

5.5.3 Management of capelin in the Iceland-East Greenland-Jan Mayen area

The fishable stock consists of 2 age groups (2 and 3 year olds, spawning at ages 3 and 4). The fishing season usually begins in June/July and ends in March of the following year when the remainder of the fishable stock spawns and dies. The fishable stock, which is also the maturing stock, is thus renewed annually and its exploitation must of necessity be cautious. Due to the short life span and high spawning mortality, stock abundance can only be assessed by acoustic surveys.

The final decision on a TAC for each fishing season has been based on the results of acoustic stock abundance surveys in late autumn or in January/February of the following year during the fishing season. Prior to that no fishery has been allowed unless an assessment has shown that at least 2-300 000 t can be taken allowing for natural mortality and a remaining spawning stock of 400 000 t.

The procedure just described has worked well in the past for ‘normal’ ranges of stock abundance. However, it is clear that extra care should be taken when dealing with stock abundance below or above the norm, corresponding to TACs lower than 500 000 t or greater than 1 600 000 t.

5.6 Precautionary Approach to Fisheries Management

Due to the short life span of capelin and their high spawning mortality, the main management objective is to maintain enough spawners for the propagation of the stock. Since 1979 the targeted remaining spawning stock for capelin in the Iceland-East Greenland Jan Mayen area has been 400 000 t. Although there have been large fluctuations in stock abundance during this period, these appear to be environmentally induced and not due to excessive fishing. Therefore, the criterion of maintaining a remaining spawning stock may be defined as B_{lim} , i.e. stock abundance below which no fishery should be permitted.

The definition of other precautionary reference points is more problematic. However, due to uncertainties inherent in predicting the abundance of short-lived species and the importance of capelin as forage fish for predators such as cod, saithe, Greenland halibut, baleen whales and sea birds, extra precaution should be taken when stock biomass projections indicate TACs lower than 500 000 t and greater than 1 600 000 t. In the former case, the fishery should not be opened until after the completion of a stock assessment survey in autumn/winter in that season. The latter simply represents a scenario where projected stock abundance is beyond the highest historical abundance on record. In such cases the preliminary TAC should not exceed 1 100 000 t.

5.7 Special Comments

In the last four years great difficulties have been encountered in locating and assessing the juvenile part of the stock (ages 1 and 2; 2 and 3 after 31 December). In this period, the quarterly monitoring of environmental conditions of Icelandic waters, shows a rise in sea temperatures north and east of Iceland, which probably also reaches farther north and northwest. The temperature increase is so large that it has probably led to displacements of the juvenile part of the capelin stock. On the basis of experience gained before and during assessment surveys of the 2002/2003 season, these displacements have obviously been so large that juvenile capelin, in particular the 2001 year class, were not available to the autumn 2002 assessment survey as it was carried out. Therefore, while the very low numbers of immature capelin of the 2001 and later year classes hitherto recorded should be taken seriously, they do not necessarily indicate a radical decline of the adult fishable stock.

An overview of stock developments during 1978–2006 is given in Table 5.7.1.

5.8 Sampling

Investigation	No. of samples	Length meas. individuals	Aged individuals
Fishery 2003	6	460	460
Survey 2003	16	1444	519
Fishery 2004	16	1600	1600
Survey 2004	31	1901	1870

Table 5.2.2 The total international catch of capelin in the Iceland-East Greenland-Jan Mayen area by age group in numbers (billions) and the total catch by numbers and weight (thousand tonnes) in the autumn season (August-December) 1984–2005.

Age	Year										
	1984	1985	1986	1987	1988	1989	1990	1991	1992	1993	1994
1	0.5	0.8	+	+	0.3	1.7	0.8	0.3	1.7	0.2	0.6
2	9.8	25.6	10.0	27.7	13.6	6.0	5.9	2.7	14.0	24.9	15.0
3	7.8	15.4	23.3	6.7	5.4	1.5	1.0	0.4	2.1	5.4	2.8
4	0.1	0.2	0.5	+	+	+	+	+	+	0.2	+
Total number	18.2	42.0	33.8	34.4	19.3	9.2	7.7	3.4	17.8	30.7	18.4
Total weight	548.5	919.7	772.9	458.6	371.4	121.0	111.2	56.0	298.1	611.6	324.1

Age	Year										
	1995	1996	1997	1998	1999	2000	2001	2002	2003	2004	2005
1	1.5	0.2	1.8	0.9	0.3	0.2	+	+	0.3	+	-
2	9.7	25.2	33.4	25.1	4.7	12.9	17.6	18.3	11.8	5.3	0.4
3	1.1	12.7	10.2	2.9	0.7	3.3	1.2	2.5	1.0	0.5	+
4	+	0.2	0.4	+	+	0.1	+	+	+	-	-
Total number	12.3	38.4	45.8	28.9	5.7	16.5	18.8	20.8	14.3	5.8	0.4
Total weight	205.7	773.7	763.6	440.5	102.4	265.1	294.0	339.7	199.5	92.0	9.0

Table 5.2.3 The total international catch of capelin in the Iceland-East Greenland-Jan Mayen area by age group in numbers (billions) and the total catch by numbers and weight (thousand tonnes) in the winter season (January-March) 1985–2006.

Age	Year										
	1985	1986	1987	1988	1989	1990	1991	1992	1993	1994	1995
2	0.4	0.1	+	+	0.1	1.4	0.5	2.7	0.2	0.6	1.3
3	9.1	9.8	6.9	23.4	22.9	24.8	7.4	29.4	20.1	22.7	17.6
4	5.4	6.9	15.5	7.2	7.8	9.6	1.5	2.8	2.5	3.9	5.9
5	-	0.2	-	0.3	+	0.1	+	+	+	+	+
Total number	14.5	17.0	22.4	30.9	30.8	35.9	9.4	34.9	22.8	27.2	24.8
Total weight	348.5	391.8	560.5	657.2	665.1	686.8	202.4	621.1	489.6	567.1	539.8

Age	Year										
	1996	1997	1998	1999	2000	2001	2002	2003	2004	2005	2006
2	0.6	0.9	0.3	0.5	0.3	0.4	0.1	0.1	0.6	0.1	0.1
3	27.4	29.1	20.4	31.2	36.3	27.9	33.1	32.2	24.6	31.5	10.4
4	7.7	11.0	5.4	7.5	5.4	6.7	4.2	1.9	3.0	3.1	0.3
5	+	+	+	+	+	+	+	+	+	-	-
Total number	35.7	41.0	26.1	39.2	42.0	35.0	37.4	34.4	28.3	34.7	10.8
Total weight	723.6	797.6	481.3	658.9	830.3	787.2	955.0	648.0	542.9	692.0	230.0

Table 5.2.4 The total international catch in numbers (millions) of capelin in the Iceland-East Greenland-Jan Mayen area in the summer/autumn season of 2005 by age and length, and the catch in weight (thousand tonnes) by age group.

Total length (cm)	Age 1	Age 2	Age 3	Total	Percentage
12	+	0.000	0.000	0.000	0.0
12.5	+	+	0.000	0.000	0.0
13	+	+	0.000	0.000	0.0
13.5	+	+	0.000	0.000	0.0
14	0.000	+	0.000	0.000	0.0
14.5	0.000	+	0.000	0.000	0.0
15	0.000	0.001	0.000	0.001	0.2
15.5	0.000	0.005	+	0.005	1.2
16	0.000	0.150	0.001	0.151	36.0
16.5	0.000	0.120	0.009	0.129	30.7
17	0.000	0.090	0.003	0.093	22.1
17.5	0.000	0.040	0.001	0.041	9.8
18	0.000	+	0.000	0.000	0.0
18.5	0.000	+	0.000	0.000	0.0
Total number	+	0.406	0.014	0.420	
Percent	0.1	96.0	3.9	100.0	100.0
Total weight	0.020	8.648	0.339	9.007	

Table 5.2.5 The total international catch in numbers (billions) of capelin in the Iceland-East Greenland-Jan Mayen area in the winter season of 2006 by age and length, and the catch in weight (thousand tonnes) by age group.

Total length (cm)	Age 2	Age 3	Age 4	Total	Percentage
12	0.078	0.000	0.000	0.078	0.7
12.5	0.008	0.002	0.000	0.010	0.1
13	0.012	0.079	0.000	0.091	0.8
13.5	0.003	0.218	0.000	0.221	2.0
14	0.000	0.268	0.000	0.268	2.5
14.5	0.000	0.756	0.000	0.756	7.0
15	0.000	1.080	0.000	1.080	10.0
15.5	0.000	1.463	0.021	1.484	13.7
16	0.000	2.366	0.071	2.437	22.6
16.5	0.000	1.853	0.098	1.951	18.1
17	0.000	1.565	0.075	1.640	15.2
17.5	0.000	0.598	0.035	0.633	5.9
18	0.000	0.137	0.000	0.137	1.3
18.5	0.000	0.015	0.000	0.015	0.1
Total number	0.100	10.400	0.300	10.800	
Percentage	0.7	95.4	4.0	100.0	100.0
Total weight	0.670	221.520	7.260	229.450	

Table 5.3.1.1 Abundance indices of 0-group capelin 1970-2003 and their division by areas.

Area	Year												
	1970	1971	1972	1973	1974	1975	1976	1977	1978	1979	1980	1981	1982
NW-Irminger Sea	1	+	+	14	26	3	2	2	+	4	3	10	+
W-Iceland	8	7	30	39	44	37	5	19	2	19	18	13	8
N-Iceland	2	12	52	46	57	46	10	19	29	25	19	6	5
East Iceland	-	+	7	17	7	3	15	3	+	1	+	-	+
Total	11	19	89	116	134	89	32	43	31	49	40	29	13

Area	Year												
	1983	1984	1985	1986	1987	1988	1989	1990	1991	1992	1993	1994	1995
NW-Irminger Sea	+	+	1	+	1	3	1	+	8	3	2	3	+
W-Iceland	3	2	8	16	6	22	13	7	2	11	21	12	6
N-Iceland	18	17	19	17	6	26	24	12	43	20	13	69	10
East Iceland	1	9	3	4	1	1	2	2	1	+	15	10	8
Total	22	28	31	37	14	52	40	21	54	34	51	94	24

	Year								
	1996	1997	1998	1999	2000	2001	2002	2003	
NW-Irminger Sea	2	5	+	NA	NA	NA	NA	+	No surveys
W-Iceland	17	14	7	25	1	25	17	+	
N-Iceland	57	30	34	51	7	53	8	4	
East Iceland	6	12	5	7	4	4	1	+	
Total	82	61	46	83	12	82	26	5	

Table 5.3.1.2 Estimated numbers, mean length and weight of age 1 capelin in the August surveys for 1983–2001.

	Year													
	1983	1984	1985	1986	1987	1988	1989	1990	1991	1992	1993	1994	1995	1996
Number (10 ⁹)	155	286	31	71	101	147	111	36	50	87	33	85	189	138
Mean length (cm)	10.4	9.7	10.2	9.5	9.1	8.8	10.1	10.4	10.7	9.7	9.4	9.0	9.8	9.3
Mean weight (g)	4.2	3.6	3.8	3.3	3.0	2.6	3.4	4.0	5.1	3.4	3.0	2.8	3.4	2.9

	Year									
	1997	1998	1999	2000	2001	2002	2003	2004	2005	
Number (10 ⁹)	143	87	55	94	99	No survey				
Mean length (cm)	9.3	9.0	9.5	9.5	10.0					
Mean weight (g)	2.8	2.9	3.2	3.1	3.7					

Table 5.3.2.1. Assessment of capelin in the Iceland/Greenland/Jan Mayen area, 26/01-02/02 2006.

(Numbers in billions, biomass in thousand tonnes)

Length (cm)	Average weight (g)	Age			Biomass	Numbers
		1	2	3		
12	5.9	0.147	0.000	0.000	0.147	0.865
12.5	9.6	0.015	0.005	0.000	0.020	0.192
13	9.4	0.022	0.209	0.000	0.231	2.165
13.5	10.2	0.005	0.576	0.000	0.581	5.930
14	12.3	0.000	0.709	0.000	0.709	8.715
14.5	14.7	0.000	1.995	0.000	1.995	29.322
15	16.5	0.000	2.849	0.000	2.849	47.007
15.5	19.3	0.000	3.860	0.080	3.940	76.040
16	21.4	0.000	6.244	0.271	6.515	139.419
16.5	24.3	0.000	4.889	0.372	5.262	127.855
17	26.2	0.000	4.130	0.285	4.415	115.508
17.5	28.2	0.000	1.579	0.132	1.712	48.268
18	31.7	0.000	0.361	0.000	0.361	11.424
18.5	32.0	0.000	0.039	0.000	0.039	1.259
Total numbers		0.188	27.445	1.140	28.776	613.969
Total biomass		1.265	585.128	27.576	613.969	
Average weight (g)		6.7	21.3	24.2	21.3	
Average length (cm)		12.2	15.9	16.6	15.9	
Percentage by number		0.7	95.4	4.0	100.0	

Table 5.4.1 The estimated number (billions) of capelin on 1 August 1978–2005 by age and maturity groups. The total number (billions) and weight (thousand tonnes) of the immature and maturing (fishable) stock components are also given.

Age/maturity	Year									
	1978	1979	1980	1981	1982	1983	1984	1985	1986	1987
1 juvenile	163.8	60.3	66.1	48.9	146.4	124.2	250.5	98.9	156.2	144.0
2 immature	15.3	16.4	4.2	3.7	15.0	42.5	40.9	100.0	29.4	37.2
2 mature	81.9	91.3	35.4	39.7	17.1	53.7	40.7	64.6	35.6	65.4
3 mature	29.1	10.1	10.8	2.8	2.3	9.8	27.9	27.0	65.8	20.1
4 mature	0.4	0.3	+	+	+	0.1	0.4	0.4	0.7	0.1
Number immat.	179.2	76.7	70.3	52.6	161.4	166.7	291.4	198.9	185.6	181.2
Number mature	111.4	101.7	46.2	42.5	19.4	63.6	69.0	92.0	102.1	85.6
Weight immat	751	366	283	209	683	985	1067	1168	876	950
Weight mature	2081	1769	847	829	355	1085	1340	1643	2260	1689

Age/maturity	Year									
	1988	1989	1990	1991	1992	1993	1994	1995	1996	1997
1 juvenile	80.8	63.9	117.5	132.9	162.9	144.3	224.1	197.3	191.2	165.4
2 immature	24.0	10.3	10.1	9.7	16.6	20.1	35.2	45.1	28.7	35.2
2 mature	70.3	42.8	31.9	67.7	70.7	86.9	59.8	102.2	100.7	90.3
3 mature	24.5	15.8	6.8	6.7	6.4	10.9	13.2	23.0	29.6	19.0
4 mature	0.4	+	+	+	+	0.2	-	+	+	+
Number immat.	104.8	74.2	127.6	142.6	179.5	164.7	259.2	242.4	219.9	200.6
Number mature	95.2	58.6	38.7	74.4	77.1	98.0	73.0	125.1	130.3	109.3
Weight immat	438	309	542	702	747	702	1019	1188	985	758
Weight mature	1663	1173	751	1273	1311	1585	1268	1819	1900	1590

Age/maturity	Year							
	1998	1999	2000	2001	2002	2003	2004	2005
1 juvenile	167.9	138.0	145.6	139.7	142.3	131.8	138.0*	NA
2 immature	19.2	24.4	25.0	9.0	23.9	11.4	2.3*	NA
2 mature	89.5	85.9	65.7	86.7	68.0	82.1	86.6	35.0
3 mature	23.2	12.6	16.0	16.9	5.9	15.7	7.5	2.3
4 mature	+	+				+		
Number immat.	187.1	162.4	170.6	148.7	166.2	143.2	55.6 ¹⁾	NA
Number mature	112.7	98.5	81.7	103.6	73.9	97.8	94.1	37.3
Weight immat	621	612	645	615	713	596	170*	NA
Weight mature	1576	1703	1519	1817	1280	1544	1481	830

* Preliminary
 NA: Not available

Table 5.4.2 The estimated number (billions) of capelin on 1 January 1979–2006 by age and maturity groups. The total number (billions) and weight (thousand tonnes) of the immature and maturing (fishable) stock components and the remaining spawning stock by number and weight are also given.

Age/maturity	Year									
	1979	1980	1981	1982	1983	1984	1985	1986	1987	1988
2 juvenile	137.6	50.6	55.3	41.2	123.7	105.0	211.6	83.2	131.9	120.5
3 immature	12.8	13.8	3.5	3.0	12.6	35.7	34.3	83.9	25.6	31.2
3 mature	51.8	53.4	16.3	8.0	14.3	39.8	25.2	34.5	22.1	34.1
4 mature	14.8	3.6	4.9	0.5	2.0	7.6	15.6	10.5	37.0	11.7
5 mature	0.3	0.2	+	+	+	0.1	0.3	0.2	0.2	+
Number immat.	150.4	64.4	58.8	44.2	136.3	140.7	245.9	167.1	157.5	151.3
Number mature	66.9	57.2	21.2	8.5	16.3	47.5	41.1	45.2	59.1	45.8
Weight immat.	1028	502	527	292	685	984	1467	1414	1003	1083
Weight mature	1358	980	471	171	315	966	913	1059	1355	993
Number sp.st.	29.0	17.5	7.7	6.8	13.5	21.6	20.7	19.6	18.3	18.5
Weight sp. st	600	300	170	140	260	440	460	460	420	400

Age/maturity	Year									
	1989	1990	1991	1992	1993	1994	1995	1996	1997	1998
2 juvenile	67.8	53.9	98.9	111.6	124.6	121.3	188.1	165.2	160.0	138.8
3 immature	20.1	8.6	8.6	8.1	13.9	16.9	29.5	37.9	24.1	29.5
3 mature	48.8	31.2	22.3	54.8	46.5	50.5	35.1	75.5	72.4	50.1
4 mature	16.0	12.1	4.5	5.3	3.5	4.6	8.7	20.1	24.8	7.9
5 mature	0.3	+	+	+	+	+	+	+	+	+
Number immat.	87.9	62.5	107.5	119.7	138.5	138.2	217.6	203.1	184.1	168.3
Number mature	64.8	43.3	26.8	60.1	50.0	55.1	43.8	95.6	97.2	58.0
Weight immat.	434	291	501	487	622	573	696	800	672	621
Weight mature	1298	904	544	1106	1017	1063	914	1820	1881	1106
Number sp.st.	22.0	5.5	16.3	25.8	23.6	24.8	19.2	42.8	21.8	27.6
Weight sp. st.	440	115	330	475	499	460	420	830	430	492

Age/maturity	Year							
	1999	2000	2001	2002	2003	2004	2005	2006
2 juvenile	140.9	115.8	122.2	117.3	109.4	132.1*	NA	NA
3 immature	16.1	20.5	21.0	7.6	9.4	11.4	NA	NA
3 mature	53.2	68.2	46.3	59.3	58.4	54.2	86.6	28.8
4 mature	16.0	10.0	10.5	10.5	2.9	6.2	7.5	1.2
5 mature	+	+	+	+		+	+	-
Number immat.	157.0	136.3	161.2	126.6	105.1	143.5*	NA	NA
Number mature	69.3	78.2	56.8	69.8	61.3	60.4	72.5	30.0
Weight immat.	585	535	655	510	487	597*	NA	NA
Weight mature	1171	1485	1197	1445	1214	1204	1450	639
Number sp.st.	29.5	34.2	21.3	22.9	20.7	28.2	36.3	18.8
Weight sp. st.	500	650	450	475	410	535	725	400

*Preliminary/Predicted

NA: Not available

Table 5.7.1 Capelin in the Iceland-East Greenland-Jan Mayen area 1978-2006. Recruitment of 1 year old fish (unit 10^9) and total stock biomass ('000 t) are given for 1 August Spawning stock biomass ('000 t) is given at the time of spawning (March next year). Landings ('000 t) are the sum of the total landings in the season starting in the summer/autumn of the year indicated and ending in March of the following year.

Year	Recruitment	Total Stock biomass	Landings	Spawning stock biomass
1978	164	2832	1195	600
1979	60	2135	980	300
1980	66	1130	684	170
1981	49	1038	626	140
1982	146	1020	0	260
1983	124	2070	573	440
1984	251	2427	897	460
1985	99	2811	1312	460
1986	156	3106	1333	420
1987	144	2639	1116	400
1988	81	2101	1037	440
1989	64	1482	808	115
1990	118	1293	314	330
1991	133	1975	677	475
1992	163	2058	788	499
1993	144	2287	1179	460
1994	224	2287	864	420
1995	197	3007	929	830
1996	191	2885	1571	430
1997	165	2348	1245	492
1998	168	2197	1100	500
1999	138	2315	933	650
2000	146	2164	1071	450
2001	140	2432	1249	475
2002	142	1993	988	410
2003	132	2540	635	535
2004	NA	NA	750	725
2005	NA	NA	552	400
2006	NA	NA	238	400

*Preliminary

NA: Not available

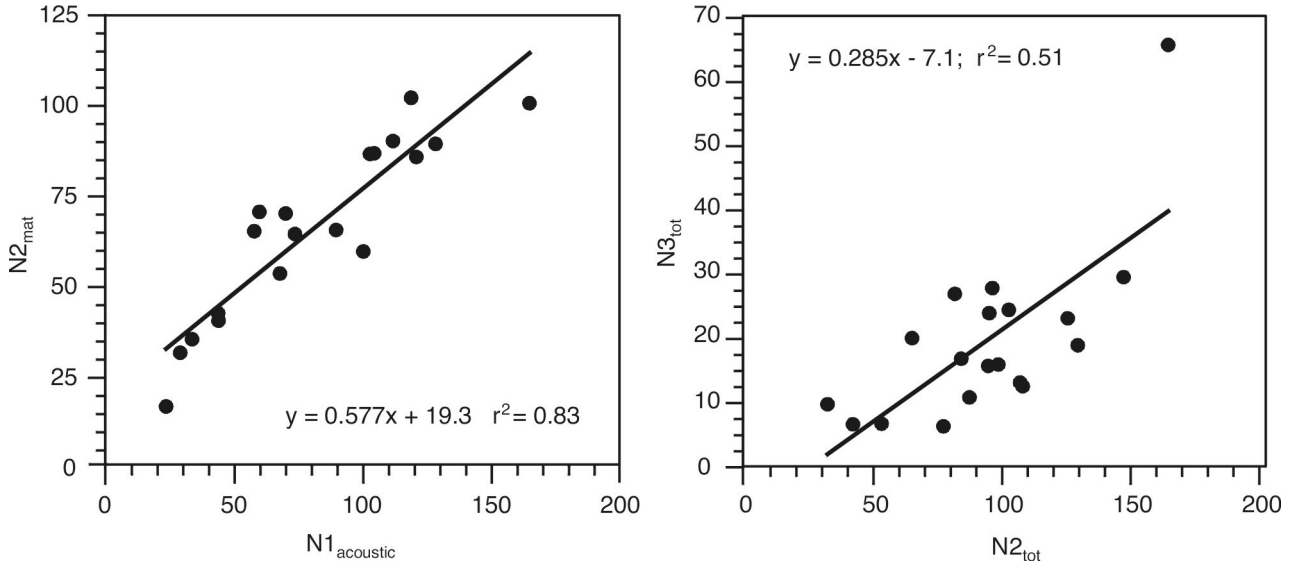

Figure 11.5.2.1. The relationship between the measured numbers of immature 1-group capelin in autumn acoustic surveys and the numbers of maturing capelin in 1 August of the following year (left hand figure) and between measured total numbers of 2-group capelin and the maturing 3-group capelin in the following year (right hand figure).

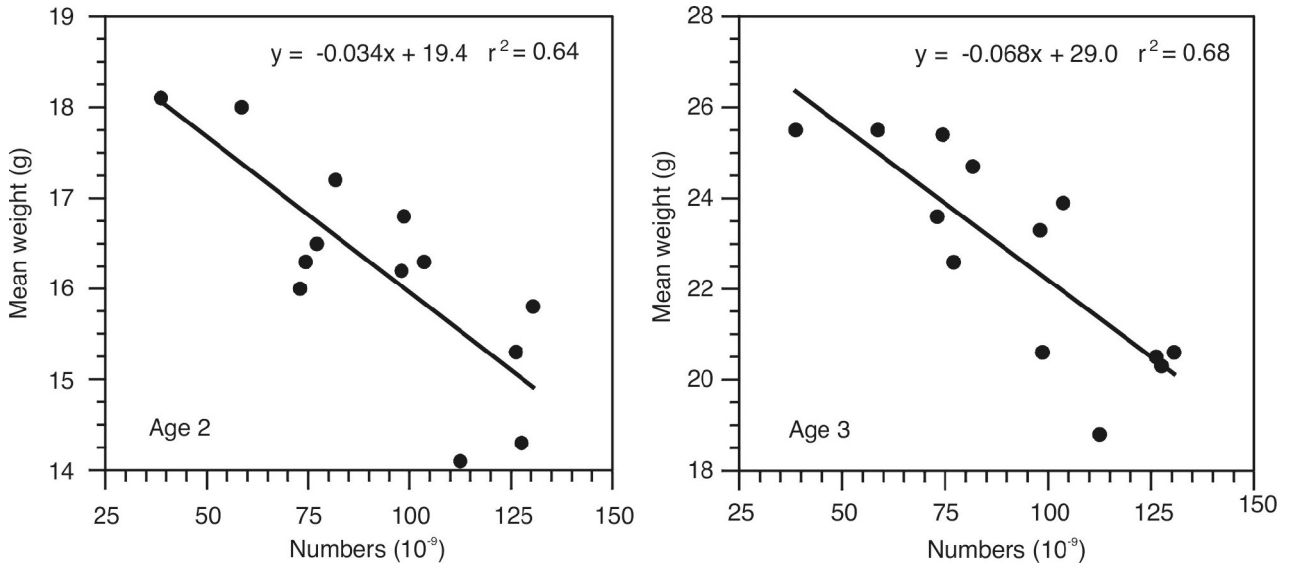

Figure 11.5.2.2. The relationship between the total numbers in the maturing stock and the mean weight of maturing 2-group (left hand figure) and 3-group (right hand figure) in autumn 1989-2001.

6 Working documents

Asta Gudmundsdottir. A small note with recalculations of catch in numbers for NSSH with datayear=2003

Asta Gudmundsdottir. Norwegian spring spawning herring Recalculations of total international catch in numbers in 2004

Asta Gudmundsdottir. Norwegian spring spawning herring Total international catch in numbers in 2005

Hoskuldur Bjornsson. Some basic things.

Mikko Heino, Henrik Sjøiland, Martin Dahl, Jaime Alvarez, Øyvind Tangen, Vladimir Shnar, Alexander Malyshko, Oleg Krasnoborod'ko, Sergey Ratushnyy, Eugene Mullins, Graham Johnston, Gavin Power, Jarle Kristiansen, Lonneke Goddijn, Jan Arge Jacobsen, Leon Smith, Mourits Mohr Joensen, Sytse Ybema, Ronald Bol, Kees Bakker, Pablo Tjoe-Awie, Jan Pedersen. INTERNATIONAL BLUE WHITING SPAWNING STOCK SURVEY SPRING 2006

Mikko Heino, Henrik Sjøiland, Martin Dahl, Jaime Alvarez, Valentine Anthonypillai, Kirsti B. Eriksen, Jan de Lange, Elna S. Meland, Ronald Pedersen, Øyvind Tangen, Terje Torkelsen, Alexander Krysov. BLUE WHITING SURVEY DURING SPRING 2006

Dmitri Vasilyev. Year class peculiarities in selection pattern: how stock assessment based on separable cohort models is able to take them into account ? (Some illustrations for triple-separable case of the ISVPA model - TISVPA)

Annex 1: List of Participants

Northern Pelagic and Blue Whiting Fisheries Working Group

ICES, Headquarters, 24-30 August 2006

NAME	ADDRESS	TELEPHONE	FAX	E-MAIL
Frans A. van Beek	Centre for Fisheries Research (CVO) P.O. Box 68 1970 AB IJmuiden Netherlands			fransa.vanbeek@wur.nl
Sergei Belikov	PINRO 6, Knipovitch Street 183763 Murmansk Russia			belikov@pinro.ru
Hoskuldur Bjornsson	Marine Research Institute P.O. Box 1390 Skúlagata 4 IS-121 Reykjavík Iceland			hoski@hafro.is
Asta Gudmundsdóttir (Chair)	Marine Research Institute P.O. Box 1390 Skúlagata 4 IS-121 Reykjavík Iceland	+354-5752000	+354-5752001	asta@hafro.is
Ane Iriondo	AZTI Txatxarramendi Irla 48395 Sukarrieta/Pedernales Spain	+34 94 602 94 00	+3494 6870006	airiondo@suk.azti.es
Jan Arge Jacobsen	Faroese Fisheries Laboratory Nóatún P.O. Box 3051 FO-110 Tórshavn Faroe Islands	+298 353900	+298 353901	janarge@frs.fo
Alexander Krysov	PINRO 6, Knipovitch Street 183763 Murmansk Russia	+7 (8152) 47 34 24	+47 789 10 518	a_krysov@pinro.ru
Manolo Meixide	Inst. Español de Oceanografía Centro Oceanográfico de Vigo Cabo Estay - Canido Apdo 1552 E-36280 Vigo Spain	+34 986 49 21 11	+34986 498626	manolo.meixide@vi.ieo.es

NAME	ADDRESS	TELEPHONE	FAX	E-MAIL
Nikolay M. Timoshenko	AtlantNIRO 5, Dmitry Donskogo Street 236000 Kaliningrad Russia			timoshenko@atlant.baltnet.ru
Sigurd Tjelmeland	Institute of Marine Research P.O.Box 1870 Nordnes N-5817 Bergen Norway	+47 55 238500	+47 55 238531	sigurd.tjelmeland@imr.no
Dimitri A. Vasilyev	Russian Federal Res. Inst. of Fisheries & Oceanography (VNIRO) 17, Verkhne Krasnoselskaya Moscow 107140 Russia	+7 095 264 99 65	+7 095 264 91 87	dvasilyev@vniro.ru
Morten Vinther	Danish Institute for Fishery Research (DIFRES) Charlottenlund Slot DK-2920 Charlottenlund Denmark	+45 33 96 33 53	+45 33 96 33 33	mv@dfu.min.dk
Sytse Ybema	IMARES Institute for Marine Research and Ecosystem Studies Haringkade 1 P.O. Box 68 NL-1970 AB IJmuiden Netherlands			Sytse.Ybema@wur.nl
Afra Egan	The Marine Institute Rinville Oranmore Co. Galway Ireland	+353 9173 0400	+353 9173 0470	afra.egan@marine.ie
Jens Chr. Holst	Institute of Marine Research P.O. Box 1870 Nordnes N-5817 Bergen Norway	+47 55 238411	+47 55 238531	jens.christian.holst@imr.no
Mikko Heino	Institute of Marine Research Box 1870 Nordnes N-5817 Bergen Norway	+47 55 23 6962	+47 55 23 8687	mikko@imr.no

NAME	ADDRESS	TELEPHONE	FAX	E-MAIL
Webjørn Melle	Institute of Marine Research P.O. Box 1870 Nordnes N-5817 Bergen Norway	+47 55 238500	+47 55 238531	webjoern@imr.no